



CELO

**Fastening
technology**

Catalogue
2024/25



Fixings technology

Catalogue
2024/25





New

Product News 2024

We know there is always room to improve.

That is why we invest a lot of energy and time in the **development** of new products and the **optimization** of existing ones.

Insulation fixings

	Resi-THERM® 12 p. 107
	IPS 80T p. 98
	IPSZ 80 p. 94
	IPSZ-H 55 p. 102

















Gas nailers and accessories

	FORCE ONE with ETA p. 235
	XHA with ETA p. 239
	SDS Plus p. 246
	NCC p. 253
	AW p. 264
	APK p. 266









Plugs

	FB p. 65
	MFR extended range p. 43

Metal anchors

		BAZ Plus HCR p. 142
		BAZ2 p. 145
		BA Plus HD, A2, A4 p. 154
		BTS4 p. 160
		BTS6 B SW13 p. 163
		BTS6 E M8 p. 163
		BTS6 H M8/M10 p. 163
	 	BTS M p. 169

Beam fixings

	CAL p. 298
	CBR p. 300
	CC p. 301
	CVA p. 303
	CAB p. 305
	CMV p. 307
	  PMV p. 308

page	Con-crete	Solid brick	Hollow brick	Aerated con-crete	Boards	Insula-tion	ETA

Standard fixings

Plug FX		23	●	●	●	●	○		
Standard plug F		26	●	●	○	●			
Standard plug FL long		29	●	●	●	●			
Multi-purpose plug MZ & MZK		31	●	●	●	●	●		
Universal plug AZ & AZK		35	●	●	●	●	●		
Aerated concrete plug GB		37				●			
Scaffold plug GR with eyebolt screw OES		39	●	●	○	○			
Blockwork anchor MSD		41	●	●	●	●			

Frame fixings

Multifunction frame plug MFR		43	●	●	●	●			
Hollow block frame plug HBR		48	○	●	●	●			
Nail plug NP		50	●	●	○	○			
Universal Spreading Nail USN		53	●	●	●				
Nail plug NPZ		55	●	●					
Quick-fix nail BN		56	●	●	○				
Distance plate DP		58							

Window frame fixings

Metal frame plug MR		61	●	●	○	○			
Window frame screw FBS		63	●	●	●	●			
Window fixing set FB		65							
Window protection ProtectFIX		67	●	●	●	●			

page	Con-crete	Solid brick	Hollow brick	Aerated con-crete	Boards	Insula-tion	ETA

Cavity Fixings

Cavity plug universal BT plus		71			○		●		
Spring toggle FK		73			○		●		
Cavity plug metal HRM		75			○		●		
Cavity fixing HR		77					●		
Plasterboard plug GKD & GKDZ		79					●		

Fixing of insulation boards

Insulation support DSH		82	●	●					
Insulation support DSH-M		82	●	●	○				
Insulation support DST & DSH-T		84							
Insulation fastener IPD		85	●	●	●	●			

Fixing to insulated façades

Insulation plug IPL 60 / IPL 95		88						●	
Insulation plug IPL 95DS		90						●	
Insulation screw IPS 80		92						●	
Insulation screw IPSZ 80		94							
Insulation screw plug IPSD 80		96						●	
Isolierplattenschraube IPS 80 T		98						●	
Insulation screw IPS-H 55		100						●	
Insulation screw IPSZ-H 55		102							
Insulation screw plug IPSD-H 55		104						●	

Distance mounting system ResiTHERM®

ResiTHERM® 16 & 12		107	●	●	●	●		●	
ResiTHERM® 37		116	○	○	●	●		●	

● very suitable

○ suitable to a limited extent

ETA approved

✓ Available in the assortment

page	Con-crete	Solid brick	Hollow brick	Aerated con-crete	Boards	Insula-tion	ETA
119	○	○	●	●			ETA

ResiTHERM® 37S



Sanitary fixings









Standing toilet installation set WC		124	●	●	●	●	●		
Standing toilet installation set FRH		126	●	●	●	●	○		
Vanity installation set WT		128	●	●	●	●	●		
Urinal installation set UB		129	●	●	●	●	●		

Metal anchors

Brass plug ME		131	●	●					
Suspended ceiling anchor DA		133	●	○					ETA
Drop-in anchor SA & SAK plus		135	●						ETA
Drop-in anchor SA & SA-N		140	●						
Bolt anchor BAZ plus for cracked and non-cracked concrete		142	●						ETA
Bolt anchor BAZ2 for cracked and non-cracked concrete		145	●						ETA
Bolt anchor BAZ for cracked and non-cracked concrete		148	●						ETA
Bolt anchor BAZ-H with washer DIN440 for woodworking		152	●						ETA
Bolt anchor BA plus for non-cracked concrete		154	●						ETA
Bolt anchor BA A4 for non-cracked concrete		158	●						ETA
Concrete screw BTS 4		160	●	○	○				
Concrete screw BTS 5		161	●	○	○				
Concrete screw BTS6		163	●	○					ETA
Concrete screw BTS		166	●						ETA
Concrete screw BTS M		169	●						U
Heavy-duty anchor SLA		171	●						ETA
Forced expansion anchor ZA		173	●						ETA

	page	Con-crete	Solid brick	Hollow brick	Aerated con-crete	Boards	Insula-tion	ETA
Sleeve anchor Dnbolt® 	175	●	○					ETA

Chemical fastening systems



Injection mortar ResiFIX VYSF 	182	●	●	●	●			ETA
Injection mortar ResiFIX VY ECO SF 	186	●	●	●	●			ETA
Injection mortar ResiFIX PYSF 	189	●	●	●	●			ETA
Injection mortar ResiFIX Pure Epoxy Plus EPP 	193	●						ETA
Injection mortar ResiFIX Pure Epoxy EP 	195	●						ETA
Manual dispenser APP 300, APVM, APP 380, OL 	197							
Sleeve SH / IGH Metal-Sleeve SH-1000 Anchor stud RESI AST 	199							
Bonded anchor VA Sharpened anchor stud VA AST 	201	●	○					ETA





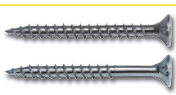
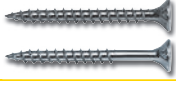

Adhesives and Sealants

StickFX Professional XP 	204	grey	All-purpose adhesive and sealant					
StickFX Professional CL 	204	transparent	Transparent adhesive and sealant					

page	black phosphated	blue zinc plated	yellow zinc plated	stainless steel A2	SIT	TX	PZ	PH	SW	ETA
------	------------------	------------------	--------------------	--------------------	-----	----	----	----	----	-----

Chipboard screws VELOX®

VELOX® SIT 	206	✓		✓	✓	✓				ETA
VELOX® Pozi 	210	✓					✓			ETA
VELOX® B 	213	✓					✓			ETA

page	black phosphated	blue zinc plated	yellow zinc plated	stainless steel A2						
------	------------------	------------------	--------------------	--------------------	---	---	---	---	---	---

Construction screws

BMax with countersunk head		216	<input checked="" type="checkbox"/>	<input type="checkbox"/>	<input type="checkbox"/>	<input type="checkbox"/>	<input checked="" type="checkbox"/>	<input type="checkbox"/>	<input type="checkbox"/>	<input type="checkbox"/>	
BMax with wafer head		217	<input checked="" type="checkbox"/>	<input type="checkbox"/>	<input type="checkbox"/>	<input type="checkbox"/>	<input checked="" type="checkbox"/>	<input type="checkbox"/>	<input type="checkbox"/>	<input type="checkbox"/>	

Other screws

Wood screw DIN 571		219	<input checked="" type="checkbox"/>	<input type="checkbox"/>	<input type="checkbox"/>	<input type="checkbox"/>	<input type="checkbox"/>	<input type="checkbox"/>	<input type="checkbox"/>	<input checked="" type="checkbox"/>	<input type="checkbox"/>
Adjustment screw JS		221	<input checked="" type="checkbox"/>	<input type="checkbox"/>	<input type="checkbox"/>	<input type="checkbox"/>	<input checked="" type="checkbox"/>	<input type="checkbox"/>	<input type="checkbox"/>	<input type="checkbox"/>	<input type="checkbox"/>
Eyebolt screw OES		222	<input checked="" type="checkbox"/>	<input type="checkbox"/>	<input type="checkbox"/>	<input type="checkbox"/>	<input type="checkbox"/>	<input type="checkbox"/>	<input type="checkbox"/>	<input type="checkbox"/>	<input type="checkbox"/>
Hanger bolt EDR		223	<input checked="" type="checkbox"/>	<input type="checkbox"/>	<input type="checkbox"/>	<input type="checkbox"/>	<input checked="" type="checkbox"/>	<input type="checkbox"/>	<input type="checkbox"/>	<input type="checkbox"/>	<input type="checkbox"/>
Wood screw with internal thread Torab® P		224	<input checked="" type="checkbox"/>	<input type="checkbox"/>	<input type="checkbox"/>	<input type="checkbox"/>	<input type="checkbox"/>	<input type="checkbox"/>	<input type="checkbox"/>	<input checked="" type="checkbox"/>	<input type="checkbox"/>
Plumber screw PLS		97	<input type="checkbox"/>	<input type="checkbox"/>	<input checked="" type="checkbox"/>	<input type="checkbox"/>	<input checked="" type="checkbox"/>	<input type="checkbox"/>	<input type="checkbox"/>	<input type="checkbox"/>	<input type="checkbox"/>

Drywall screws

Fine thread screw SSF		227	<input checked="" type="checkbox"/>	<input type="checkbox"/>	<input type="checkbox"/>	<input type="checkbox"/>	<input type="checkbox"/>	<input type="checkbox"/>	<input checked="" type="checkbox"/>	<input type="checkbox"/>	<input type="checkbox"/>
Coarse thread screw SSG		227	<input checked="" type="checkbox"/>	<input type="checkbox"/>	<input type="checkbox"/>	<input type="checkbox"/>	<input type="checkbox"/>	<input type="checkbox"/>	<input checked="" type="checkbox"/>	<input type="checkbox"/>	<input type="checkbox"/>
Drill point screw SSB		227	<input checked="" type="checkbox"/>	<input type="checkbox"/>	<input type="checkbox"/>	<input type="checkbox"/>	<input type="checkbox"/>	<input type="checkbox"/>	<input checked="" type="checkbox"/>	<input type="checkbox"/>	<input type="checkbox"/>
Fibreboard screw GSH		228	<input checked="" type="checkbox"/>	<input type="checkbox"/>	<input type="checkbox"/>	<input type="checkbox"/>	<input type="checkbox"/>	<input type="checkbox"/>	<input checked="" type="checkbox"/>	<input type="checkbox"/>	<input type="checkbox"/>
Drywall-to-drywall screw GGG		228	<input checked="" type="checkbox"/>	<input type="checkbox"/>	<input type="checkbox"/>	<input type="checkbox"/>	<input type="checkbox"/>	<input type="checkbox"/>	<input checked="" type="checkbox"/>	<input type="checkbox"/>	<input type="checkbox"/>
Metal framing screw PVS		228	<input type="checkbox"/>	<input checked="" type="checkbox"/>	<input type="checkbox"/>	<input type="checkbox"/>	<input type="checkbox"/>	<input type="checkbox"/>	<input checked="" type="checkbox"/>	<input type="checkbox"/>	<input type="checkbox"/>





















Accessories for screws











Self-adhesive PVC cover Magic Tap		230
SIT®-Bits		232
PH-Bits		233
PZ-Bits		233
TX-Bits		233
Duo-Bits		233

Gas nailers

Gas nailer FORCE ONE			235
Battery FONEBAT Charger FONECARSET			238
Fuel cell for FORCE ONE GASFONE			238
Steel nails XHA for FORCE ONE			239
Steel nails TKA for FORCE ONE			239
Gas nailer FOX			241
Battery FOXBAT Charger FOXCARSET			244
Fuel cell for FOX GASA			244
Steel nails XHA / TKA for FOX			245
Pre-nailing drill bit SDS Plus			246
Magnetic holder for FOX FOXMH			247





Gas nailers accessories

Multidiameter nylon clamp Abranyl® ABT			250
Pipe ring clip UT			251
Nylon clip for flat cables TPC / TPLC			252
Nailing cable clasp NCC			253
Wire conduit WSC / WDC			254
Cable tie fasteners TBB			255
Cable tie fasteners TBBL			255
Cable tie fasteners TBBD			255
Cable tie fasteners TBM			255
Conduit clip FP / FPD			257
Metal cable hanger CHS			258
Metal conduit clip PFT / DFT			259







Stud accessory ATR			261
Rod hanger ATV			262
Ceiling hanger AAT			263
Metal washer AW			264
Plastic washer AP			265
Plastic washer APK			266
Black textile strip TXS			267

 ETA when combining approved accessories, XHA-nails (22-38 mm) and Premium gas nailer FORCE ONE

Plastic clamps

Plastic clamp Abranyl® AN		271
Plastic clamp Abranyl® ABT		273
Plastic clamp Abranyl® ABM		272
Multiclip MC		273
Pipe ring clip UT		274

Metal clamps

Quick clamp RIF		277
Clamp RI		278
Sliding pipe clamp RID		280
Metal clamp LI		281
Metal clamp L		282
Heavy-duty metal drainage clamp D		283
Hose clamp SF		284

Important Information about the 2024/25 Catalogue

- Our General Terms and Conditions apply exclusively
- When using our products, please take note of instructions found in brochures, assessments, and on our homepage
- Our products may be subject to change without notice if these changes serve technical improvements
- Invoicing is only done through commercial customers
- Returning goods only through prior agreement and indication of delivery note number
- Products with blue printed article numbers extended delivery times possible
- For deliveries of the FORCE ONE range, transport cost surcharges may apply in some countries



At CELO, we know that our screws and fixings contribute only a very small part to the entire project.

We take care in making our products competitive, while our main goal is to develop and innovate in products and services that reduce your costs... from design to installation.

- **Your time. Our value.**
- **Innovation**
- **Know-how**
- **Quality**



Company

At CELO, we take care of the small things

Small Things Matter

Just look around you. The world is made of small pieces that, united, form something greater. We know that in the end it's the little things that make a huge difference and that's why we, as experts, take care of every detail - from development to application. Things - sometimes as small as a plug or a screw.

Multifunction frame plug MFR

Enables universal mounting of façade substructures as well as wood and metal parts in all common base materials.



Selfdrilling screw with metric thread Torab

For metal profiles of 1-6 mm thickness. With metric connecting thread for efficient installation of clamps.



Standard plug F

The classic with high pull-out loads even in perforated brick and aerated concrete, consisting of high-quality and ageing resistant nylon.



Profiles and struts

Metal rails and profiles for versatile electrical and sanitary installations.



Construction screw BMax

The approved BMax screw fulfills highest requirements for use in timber construction.



VELOX® screws

With a true passion for details CELO offers chipboard screws with ETA assessment and SIT recess.



Quick clamp RIF

Quick installation of hot water and heating pipes thanks to a clever closure with only one screw



Suspended ceiling anchor DA

The reduced anchorage depth reduces rebar hits and saves time. With ETA assessment.



Nylon clamp multi-diameter Abranyl® ABM

The clamp closes automatically when the pipe is pushed in. And: Only one clamp for several pipe diameters



Bolt anchor BAZ plus

For a variety of applications. A plus in user-friendliness due to the setting depth marking ring. Highest load values for your safety.



ResiFIX VYSF

With option 1 for cracked concrete, earthquake and fire resistance testing. You certainly have the right product for your project!



Small Thin

Concrete screw BTS

High loads, easy installation. Extended range with ETA assessment for cracked concrete.



Concrete screw BTS6

Fast and direct fixing in concrete for a wide range of installations. Available in many different types for various applications.



Sanitary fixings FRH

Easy and fast. The sanitary sets from CELO save time during your sanitary installation.



Cavity plug BT plus

The universal, fast and strong cavity fixing. Easy handling.



Insulation screw IPS 80

Innovative solution for direct mounting into ETICS. Fast fixing of wall connection profiles without thermal bridge. Available in many colours.



Insulation plug IPL 95DS

Simple, fast, flexible and adjustable! Reliable fastening of rainwater downpipes in ETICS. Direct fastening in the insulation material - No thermal bridge.



Distance mounting system ResiTHERM® 16

Perfect solution for safety-critical fixings at the insulated façade! No thermal bridge. Suitable for high loads.



Fast push-in plug InsertFIX for cable ties

Drill a 6 mm hole. Press the plug in with your finger and achieve high loads - quick and easy.



The ultimate gas nailer FORCE ONE

The lightweight, powerful and ergonomic gas nailer.



ings Matter

Quality, know-how and innovation

CELO's vision is to become an international leader in innovative technical screws and technical fixings that reduce time and cost of installations and assemblies:

$$CELO \#1 = \left(\frac{\text{Lightbulb} \times \text{Globe}}{\text{Clock} + \text{Euro/Dollar Symbols}} \right) \text{CELO TEAM}$$

A simple equation represents our DNA

- In the numerator: Knowledge, innovation and international reach allow our company to grow.
- In the denominator: Fixings, that reduce time and cost of installation help our customers to be competitive.
- The CELO team is the part of the equation that potentiates our development.

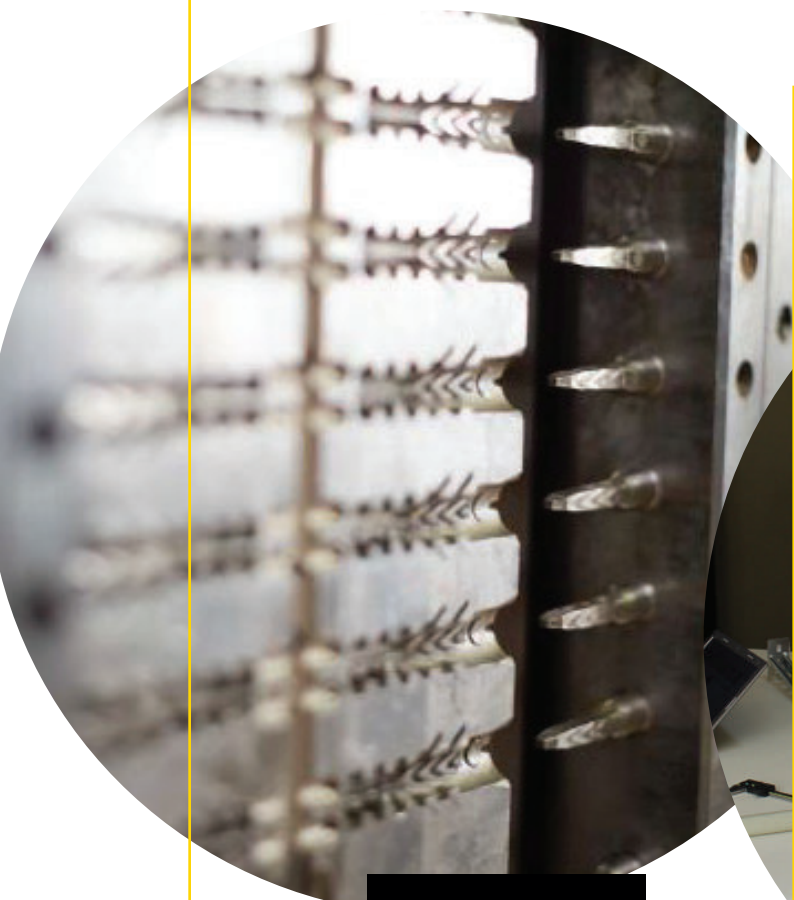

Quality "Made in Germany"

In-house development department





**Solutions
for every need**

**Uncompromising
customer focus**



Your benefits

- **Innovative solutions**, that save the user time and money.
- **Extensive range of products** for distributors and end consumers.
- **Partnership based cooperation** and a fair price-performance ratio.
- **Many years of experience** in the development and manufacturing of fixing systems.
- **Highest product quality** ensured by top-grade raw materials and proven functionality shown by many ETA assessments.
- **Strong partner**, thanks to worldwide presence and manufacturing facilities of the CELO Group.
- **Member of the CFG Trade Association.** New trends in the industry at firsthand.



Customer Service

Phone	+49 (0) 8251 90 485 0	Service time	
Fax	+49 (0) 8251 90 485 49	Mon - Thu	7:30 - 17:00
E-Mail	info@celofixings.de	Fri	7:30 - 14:00



Field Service

- Committed – competent – flexible
- Extensive field service care
- Personal consultation
- Product recommendations
- Shelf planning and shelf service
- Roadshow

Democar

- Service for our dealers
- Technical support
- Theoretical and practical product training
- Pull-out tests on site
- Training and advice of end users*
- Construction site visit*

*in consultation with your specialised dealer



Training center

- Teaching technical knowledge of fixing technology
- Theoretical and practical product training
- Exchange of experiences
- Factory tour
- Small seminar groups (max. 15 people)
- Certificate for successful participation

Design Software - Anchors + Screws

MFR frame plug design software "Frameplug Design"

- Calculation, how many MFR frame plugs are needed to fix your façade substructure / ventilated façade - according to current standards, EAD and TR
- Real-time calculation with automatic determination of the most economical result
- Easy entry of wind zones by city or postcode (Germany and Spain) - to be extended
- Comprehensive 3D visualisation including battens and insulation

Design Software - Anchors

- Design of heavy-duty anchors - metal and chemical anchors - in concrete
- Fast real time calculation
- Intuitive user interface including 3-dimensional graphics
- Flexible anchor positioning for various base plate geometries
- Perfect for planners and architects
- Professional and clear documentation
- Available in many languages
- Great features
- Stress visualisation of the base plate (FEM calculation)
- Further modules will follow

Design Software - Screws

- Calculation of on-rafter insulation and universal connections (wood-wood / steel-wood)
- Predefined wind and snow loads in the module on-rafter insulation by postal code
- Support already during the design of each application
- Real-time calculation with automatic determination of the most economic result
- Design of BMax and VELOX® SIT screws according to ETA, EN 19951-1 and DIN EN 1995-1-1 / NA

Free download at www.celofixings.com

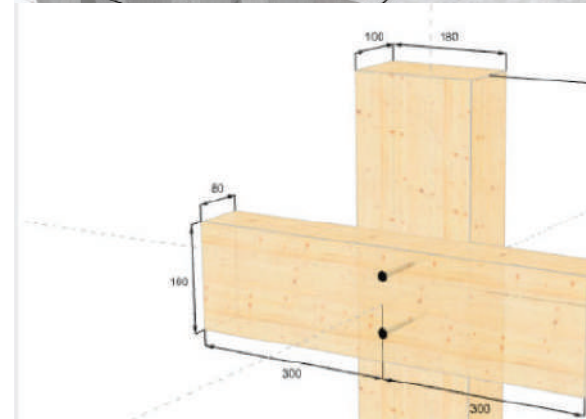
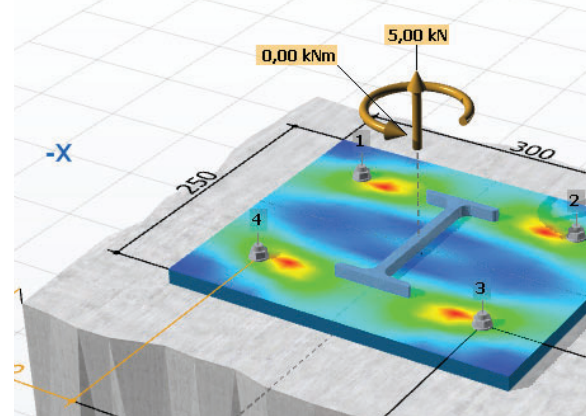
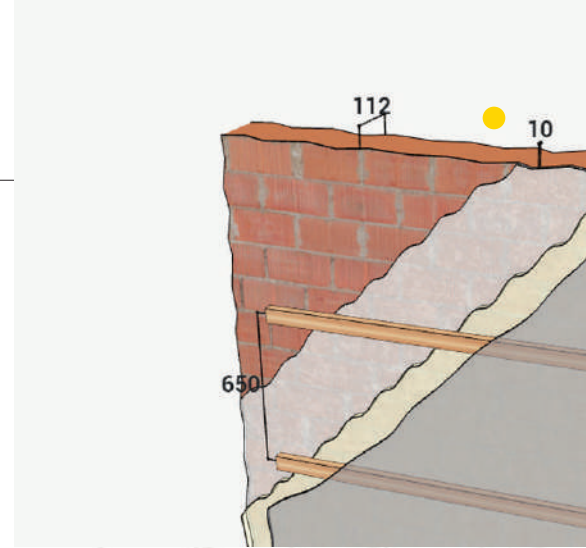

Application technology

- Design calculation for anchors, also for façades
- Pull-out tests on construction sites
- Technical telephone advice
- Tips and recommendations for all anchor questions

www.celofixings.com

- Up-to-date product information with search function
- Approvals, DoPs, safety data sheets
- Installation videos
- Catalogues and flyers
- News and events
- Installation instructions for anchors
- Download links for the design softwares







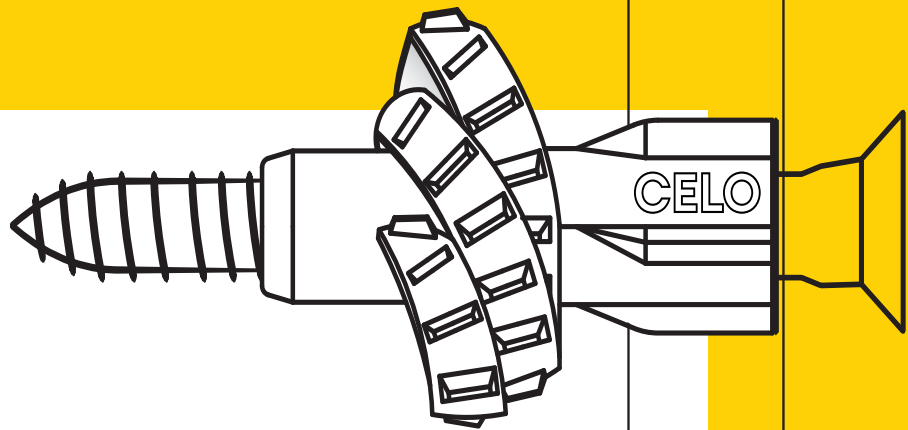





Used symbols and icons

Symbol	Explanation	Symbol	Explanation
	The European Technical Approval/Assessment (ETA) is a widely accepted confirmation of technical suitability of a building product in accordance with the Construction Products Regulation (CPR) in the member states of the EU.		With halogen-free plastic products , no toxic or corrosive gases are released in case of fire. Therefore, a dangerous release of halogen-containing fire gases can be excluded when using these products.
	By affixing the CE mark the manufacturer declares that the product meets the valid European standards . CE-marked products can be freely distributed in the European Economic Area.		The Prüfzentrum für Bauelemente (PfB) in Rosenheim is an accredited and notified testing and certification centre, specialised in testings in the fields of safety, climate / weather, energy and usability.
	The Ü mark certifies general building inspectorate assessment for building products issued by DIBt in Berlin, the German Institute of Civil Engineering.		Products labelled with this symbol are made of stainless steel (A4 or A2) and are thus generally suitable for outdoor usage.
	The EU-directive RoHS restricts the use of certain hazardous substances in electrical and electronic equipment. It's purpose is the protection of human health and the environmental disposal of this equipment. It indicates that the anchor does not contain any of these hazardous substances.		Leadership in Energy and Environmental Design (LEED) is a green building certification system. It is a global sustainability certificate and defines a series of standards for environmentally friendly, low-pollutant, low-emission and sustainable building.
	Fire resistance class, i.e. fire-resistant product The fire resistance stands for the time in minutes that the anchor continues to perform its function, with decreasing performance, when exposed to fire.		Émissions dans l'air intérieur is a French VOC label used to test emissions from building products. The test specification complies with ISO 16000 and corresponds to the statutory methodology for the evaluation of the health impact of building materials applicable in Germany.
	The product is suitable for use as an anchor subjected to seismic loading according to the European Technical Approval/Assessment. The seismic performance of anchors subjected to seismic loading is categorized by performance categories C1 and C2.		Kiwa specialises in quality testing and certification of products and systems, as well as environmental protection services.
	Sprinkler mark Products bearing this label may be used to fix fire extinguishing pipe systems to concrete ceilings. They comply with the current VdS guidelines.		Underwriters Laboratories (short: UL) is an independent organization headquartered in the USA that tests and certifies products for safety.
	"Best Nylon Quality" stands for products made of weatherproof and ageing resistant nylon (polyamide).		REACH is an European chemicals regulation for the registration, evaluation, labelling, authorisation and restriction of critical chemical substances. CELO products are REACH compliant.
	MS polymers are adhesives and sealants with outstanding properties that are used in a wide range of applications.		The product has an European Technical Approval/Assessment (ETA) for use in precast pre-stressed hollow core slabs .



Standard Fixings

FX		23
F		26
FL		29
MZ/MZK		31
AZ/AZK		35
GB		37
GR		
OES		39
AK		
MSD		41

Plug FX



Advantages



- 4-side expansion for high pull out loads
- Compatible with different types of screws such as wood screws, chipboard screws, self-tapping screws, etc.
- Efficient anti-rotation lugs prevents rotation in the drill hole
- Plug collar prevents slipping into the drill hole
- High quality and ageing resistant nylon
- Temperature resistant from -40°C to +80°C

Suitable building materials

Very suitable



- Concrete
- Lightweight solid concrete blocks
- Solid brick
- Solid sand-lime brick
- Natural stone
- Aerated concrete
- Hollow brick
- Hollow sand-lime brick
- Lightweight hollow concrete blocks
- Gypsum blocks

Suitable to a limited extent



- Plasterboard/
Fibreboard
- Boards

Approvals and certificates



Mounting

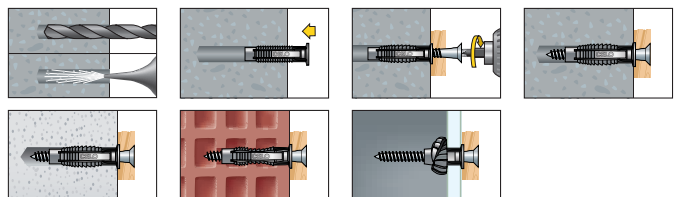

Plug FX

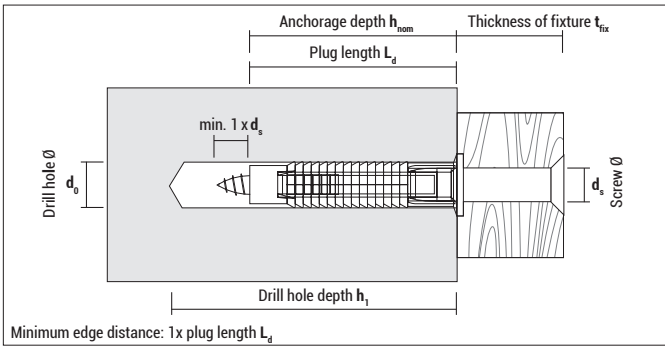

FX without screw

Type	Art-No	d ₀ [mm]	h ₁ ≥ [mm]	h _{nom} ≥ [mm]	L _d [mm]	d _s [mm]	€ / 100 pcs	[pcs]	[pcs]
FX 5	95FX	5	35	24	25	2,5 - 4		100	6.000
FX 6	96FX	6	40	29	30	3,5 - 5		100	6.000
FX 8	98FX	8	55	39	40	4,5 - 6		100	2.700
FX 10	910FX	10	70	49	50	6 - 8		50	1.350
FX 12	912FX	12	80	59	60	8 - 10		25	675



FX incl. PZ chipboard screw (FX6 and FX8) respectively hex-head wood screw (FX 10)

Type	Art-No	d ₀ [mm]	h ₁ ≥ [mm]	h _{nom} ≥ [mm]	L _d [mm]	d _s x L _s ¹ [mm]	€ / 100 pcs	[pcs]	[pcs]
FX 6 SPS	96FXSZ	6	40	29	30	4,5 x 45		50	3.000
FX 8 SPS	98FXSZ	8	55	39	40	5,0 x 60		50	1.350
FX 10 SKS	910FXK	10	70	49	50	7,0 x 65		25	675

¹ L_s = Screw length



FX in round box

Type	Art-No	d ₀ [mm]	h ₁ ≥ [mm]	h _{nom} ≥ [mm]	L _d [mm]	d _s [mm]	€ / box	[pcs]	[boxes]
FX 6	96EXPFX	6	40	29	30	3,5 - 5		300	10
FX 8	98EXPFX	8	55	39	40	4,5 - 6		125	10
FX 10	910EXPFX	10	70	49	50	6 - 8		70	10



FX Round box dispenser (empty); 44 x 56 x 30 cm (W x H x D)

Type	Art-No	€ / pcs	[pcs]
FXxcover for round box dispenser	CARTELAFX	on request	1
Round box dispenser	010507411	on request	1
Hook for dispenser	010507441	on request	1

Plug FX

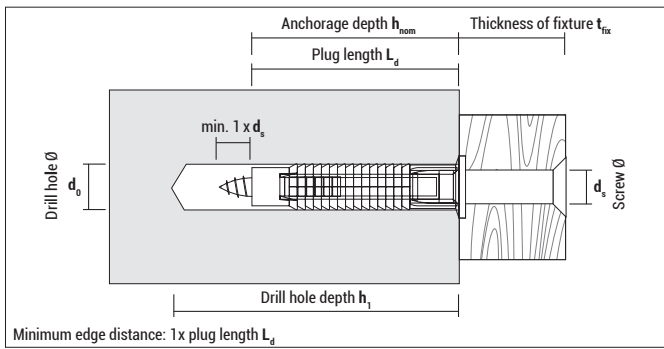

Blister FX without screw

Type	Art-No	d_0 [mm]	$h_1 \geq$ [mm]	$h_{nom} \geq$ [mm]	L_d [mm]	d_s [mm]	€/Blister	[pcs]	[Blister]
FX 5	55FX50	5	35	24	25	2,5 - 4		50	10
FX 6	56FX30	6	40	29	30	3,5 - 5		30	10
FX 8	58FX20	8	55	39	40	4,5 - 6		20	10
FX 10	510FX10	10	70	49	50	6 - 8		10	10
FX 12	512FX6	12	80	59	60	8 - 10		6	10



Blister FX incl. PZ chipboard screw (FX 5, 6 and 8) respectively hex-head wood screw (FX 10 and 12)

Type	Art-No	d_0 [mm]	$h_1 \geq$ [mm]	$h_{nom} \geq$ [mm]	L_d [mm]	$d_s \times L_s$ [mm]	Type of screw	€/Blister	[pcs]	[Blister]
FX 5 SPS	55FXSZ20	5	35	24	25	3,5 x 35			20	10
FX 6 SPS	56FXSZ15	6	40	29	30	4,5 x 45			15	10
FX 8 SPS	58FXSZ10	8	55	39	40	5,0 x 60			10	10
FX 10 SKS	510FXK5	10	70	49	50	7,0 x 65			5	10
FX 12 SKS	512FXK2	12	80	59	60	8,0 x 80			2	10

Recommended loads F_{rec} using wood screws with the largest applicable screw diameter and full anchorage depth

Type	Screw \varnothing d_s [mm]	Concrete F_{rec} [kN]	Solid stone Mz 12 F_{rec} [kN]	Solid sand- lime brick KS 12 F_{rec} [kN]	Aerated concrete AAC2 F_{rec} [kN]	Aerated concrete AAC4 F_{rec} [kN]	Hollow brick HLz 12 F_{rec} [kN]	Hollow sand- lime brick KSL 12 F_{rec} [kN]
FX 5	4	0,20	0,21	0,21	0,03	0,05	0,15	0,23
FX 6	5	0,47	0,42	0,42	0,05	0,10	0,20	0,39
FX 8	6	0,52	0,50	0,50	0,10	0,14	0,23	0,60
FX 10	8	1,28	0,90	0,90	0,16	0,30	0,45	0,67
FX 12	10	1,91	1,10	1,10	0,28	0,40	0,50	0,74

F_{rec} : Recommended loads incl. safety factor of 7

Values must be reduced by ca. 40% when using chipboard screws (especially in solid building materials)

Standard plug F



Advantages



- High pull out loads due to high expansion ability (four-sided expansion in the middle section)
- Very good screw guidance, i.e. the screw cannot move out of the plug during the screwing in
- Good twist resistance
- Strong design prevents bending when hammered in
- Good load values even in many perforated bricks and aerated concrete

Suitable building materials

Very suitable



- | | |
|---|--|
| <ul style="list-style-type: none"> • Concrete • Natural stone • Solid brick • Solid sand-lime brick | <ul style="list-style-type: none"> • Lightweight solid concrete blocks • Aerated concrete • Gypsum blocks |
|---|--|

Suitable to a limited extent



- | | |
|--|--|
| <ul style="list-style-type: none"> • Hollow brick • Hollow sand-lime brick | <ul style="list-style-type: none"> • Lightweight hollow concrete blocks |
|--|--|

Approvals and certificates



Mounting

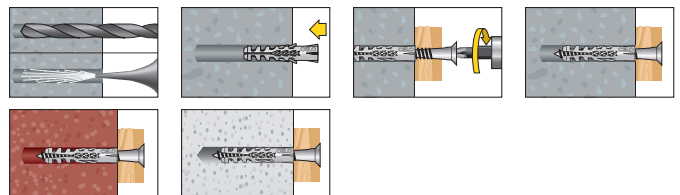

Standard plug F

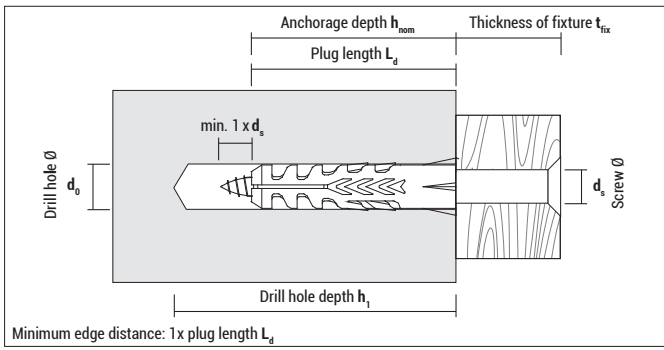

F without screw

Type	Art-No	d_0 [mm]	$h_1 \geq$ [mm]	$h_{nom} \geq$ [mm]	L_d [mm]	d_s [mm]	€/ 100 pcs	[pcs]	[pcs]
F 4	94NF	4	30	20	20	2 - 3		200	12.000
F 5	95NF	5	35	25	25	2,5 - 4		100	6.000
F 6	96NF	6	40	30	30	3,5 - 5		100	6.000
F 7	97NF	7	40	30	30	4 - 5,5		50	3.000
F 8	98NF	8	55	40	40	4,5 - 6		100	2.700
F 10	910NF	10	70	50	50	6 - 8		50	1.350
F 12	912NF	12	80	60	60	8 - 10		25	675
F 14	914NF	14	90	70	70	10 - 12		20	540
F 16	916NF	16	100	80	80	12 - 14		10	270
F 20	920NF	20	120	90	90	16		5	135

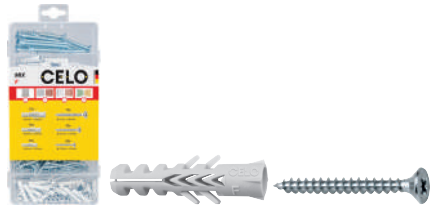

Assortment box F with screw (210 pieces in total)

Type	Art-No	Box contains	d_0 [mm]	$h_1 \geq$ [mm]	L_d [mm]	d_s [mm]	€/ box	[box]	Min. sales unit [pcs]
F	MIXNFSZ210	60 Standard plug F 5 incl. SPS 3,5x35 V, Pozi 30 Standard plug F 6 incl. SPS 4,5x45 V, Pozi 15 Standard plug F 8 incl. SPS 5,0x60 V, Pozi	5 6 8	35 40 55	25 30 40	3,5 x 35 4,5 x 45 5,0 x 60		1	5

Packed in robust plastic box



Assortment box MZK and F without screw (156 pieces in total)

Type	Art-No	Box contains	d_0 [mm]	$h_1 \geq$ [mm]	L_d [mm]	d_s [mm]	€/ box	[box]	Min. sales unit [pcs]
MZK and F	MIXNFMZK156	30 Multi-purpose plug MZK 6 15 Multi-purpose plug MZK 8 6 Multi-purpose plug MZK 10 60 Standard plug F 5 30 Standard plug F 6 15 Standard plug F 8	6 8 10 5 6 8	40 60 75 35 40 55	30 49 60 25 30 40	3,0 - 4,5 4,0 - 6,0 6,0 - 8,0 2,5 - 4,0 3,5 - 5,0 4,5 - 6,0		1	5

Packed in robust plastic box

Standard plug F



Blister F without screw



Type	Art-No	d ₀ [mm]	h ₁ ≥ [mm]	h _{nom} ≥ [mm]	L _d [mm]	d _s [mm]	€ / Blister	[pcs]	[Blister]
F 4	54NF20	4	30	20	20	2-3		20	10
F 4	54NF50	4	30	20	20	2-3		50	10
F 5	55NF20	5	35	25	25	2,5-4		20	10
F 5	55NF50	5	35	25	25	2,5-4		50	10
F 6	56NF20	6	40	30	30	3,5-5		20	10
F 6	56NF50	6	40	30	30	3,5-5		50	10
F 7	57NF20	7	40	30	30	4-5,5		20	10
F 7	57NF50	7	40	30	30	4-5,5		50	10
F 8	58NF20	8	55	40	40	4,5-6		20	10
F 8	58NF40	8	55	40	40	4,5-6		40	10
F 10	510NF5	10	70	50	50	6-8		5	10
F 10	510NF20	10	70	50	50	6-8		20	10
F 12	512NF5	12	80	60	60	8-10		5	10
F 12	512NF8	12	80	60	60	8-10		8	10

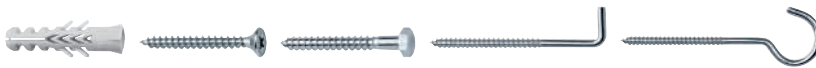

Blister F with screw



Type	Art-No	d ₀ [mm]	h ₁ ≥ [mm]	h _{nom} ≥ [mm]	L _d [mm]	d _s x L _s [mm]	Type of screw	€ / Blister	[pcs]	[Blister]
F 4 SPS	54NFSZ20	4	30	20	20	3,0 x 25			20	10
F 5 SPS	55NFSZ20	5	35	25	25	3,5 x 35			20	10
F 6 SPS	56NFSZ20	6	40	30	30	4,0 x 40			20	10
F 6 WH	56NFWH5	6	40	30	30	4,2 x 40			5	10
F 6 RH	56NFRH5	6	40	30	30	4,2 x 65			5	10
F 8 SKS	58NFK5	8	55	40	40	5,0 x 50			5	10
F 8 WH	58NFWH5	8	55	40	40	5,0 x 50			5	10
F 8 RH	58NFRH5	8	55	40	40	5,4 x 80			5	10
F 8 SPS	58NFSZ20	8	55	40	40	5,0 x 50			20	10
F 10 SKS	510NFK5	10	70	50	50	7,0 x 65			5	10
F 12 SKS	512NFK2	12	80	60	60	8,0 x 80			2	10
F 12 SKS	512NFK5	12	80	60	60	8,0 x 80			5	10
F 14 SKS	514NFK2	14	90	70	70	10,0 x 90			2	10

Recommended loads F_{rec} using wood screws with the largest applicable screw diameter and full anchorage depth

Type	Screw Ø d _s [mm]	Concrete F _{rec} [kN]	Solid stone Mz 12 F _{rec} [kN]	Solid sand-lime brick KS 12 F _{rec} [kN]	Aerated concrete AAC2 F _{rec} [kN]	Aerated concrete AAC4 F _{rec} [kN]	Hollow brick HLz 12 F _{rec} [kN]
F 4	3	0,12	0,14	0,14	-	-	0,08
F 5	4	0,23	0,24	0,33	0,04	0,04	0,09
F 6	5	0,31	0,38	0,37	0,05	0,06	0,12
F 8	6	0,34	0,46	0,43	0,07	0,07	0,13
F 10	8	0,77	0,79	0,78	0,10	0,10	0,22
F 12	10	1,55	1,57	1,90	0,15	0,16	0,30
F 14	12	2,71	-	-	-	0,28	0,43
F 20	16	5,50	-	-	-	-	-

F_{rec}: Recommended loads incl. safety factor of 7

Values must be reduced by ca. 40% when using chipboard screws (especially in solid building materials)

Standard plug extra long FL

Advantages



FL 6-60, 8-80, 10-90



FL with sleeve: FL 8-100, 8-120

- The extra long expansion area enables fixings in solid and perforated material with dense and porous structure (e.g. old buildings)
- The multiple wing construction secures an anti-rotating effect
- The FL has no collar; it can be used for pre-inserted mounting and through-mounting
- The FL is also suitable for reduced setting depth for bridging thin insulations, plaster, etc.

Suitable building materials

Very suitable



- Concrete
- Natural stone
- Solid brick
- Solid sand-lime brick
- Lightweight solid concrete blocks
- Aerated concrete
- Gypsum blocks
- Hollow brick
- Hollow sand-lime brick
- Lightweight hollow concrete blocks

Approvals and certificates



Mounting

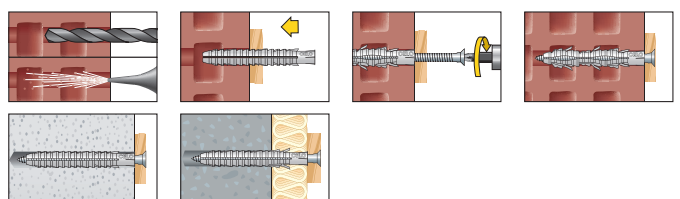

Standard plug FL long

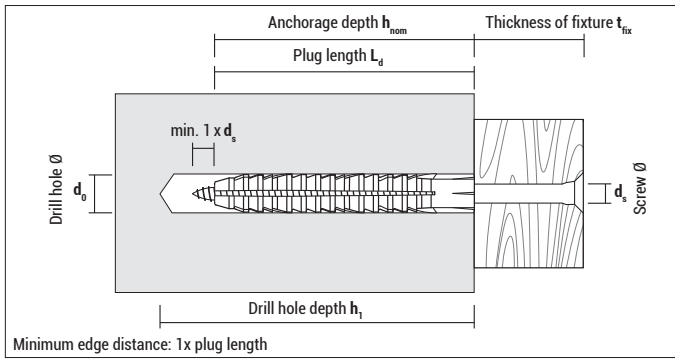

FL without screw

Type	Art-No	d ₀ [mm]	h ₁ ≥ [mm]	h _{nom} ≥ [mm]	L _d [mm]	t _{fix} ≤ [mm]	d _s [mm]	€ / 100 pcs	[pcs]	[pcs]
FL 6x60	9660FL	6	70	60	60	–	3,5 - 4,5		100	2.700
FL 8x80	9880FL	8	90	80	80	–	4,5 - 5,5		50	600
FL 8x100*	98100FL	8	90	80	100	20	4,5 - 5,5		50	600
FL 8x120*	98120FL	8	90	80	120	40	4,5 - 5,5		50	600
FL 10x90	91090FL	10	105	90	90	–	6 - 7		25	300

* with sleeve



Blister FL without screw

Type	Art-No	d ₀ [mm]	h ₁ ≥ [mm]	h _{nom} ≥ [mm]	L _d [mm]	d _s [mm]	€ / Blister	[pcs]	[Blister]
FL 6x60	5660FL10	6	70	60	60	3,5 - 4,5		10	10
FL 8x80	5880FL10	8	90	80	80	4,5 - 5,5		10	10
FL 10x90	51090FL5	10	105	90	90	6 - 7		5	10

Recommended loads F_{rec} using wood screws with the largest applicable screw diameter and full anchorage depth

Type	Screw Ø d _s [mm]	Concrete F _{rec} [kN]	Aerated concrete AAC2 F _{rec} [kN]	Aerated concrete AAC4 F _{rec} [kN]	Aerated concrete AAC6 F _{rec} [kN]	Hollow sand-lime brick KSL 12 F _{rec} [kN]	Hollow brick HLz 12 F _{rec} [kN]
FL 6x60	4,5	0,17	0,05	0,07	0,15	0,13	0,10
FL 8x80, 8x100, 8x120	5,5	0,33	0,09	0,14	0,30	0,15	0,12
FL 10x90	7	0,56	0,19	0,25	0,33	0,22	0,20

F_{rec}: Recommended loads incl. safety factor of 7

In solid building materials use smaller screw diameter

Values must be reduced by ca. 30% when using chipboard screws (especially in solid building materials)

Multi-purpose plug

MZ & MZK

Advantages



Multi-purpose plug MZ



Multi-purpose plug MZK with collar

- Knotting plug that has proven its qualities millions of times; excellent performance in almost every building material
- The 4-sided expansion in solid building materials and the knotting in perforated bricks or board materials always provides a secure fixing with high pull out loads
- High quality polyethylene guarantees long lasting elasticity and reliable knotting behaviour
- Compatible with many types and sizes of screws

Suitable building materials

Very suitable



- Concrete
- Natural stone
- Solid brick
- Solid sand-lime brick
- Lightweight solid concrete blocks
- Aerated concrete
- Gypsum blocks
- Hollow brick
- Hollow sand-lime brick
- Lightweight hollow concrete blocks
- Plasterboard/ Fibreboard
- Chipboard



Approvals and certificates



Mounting

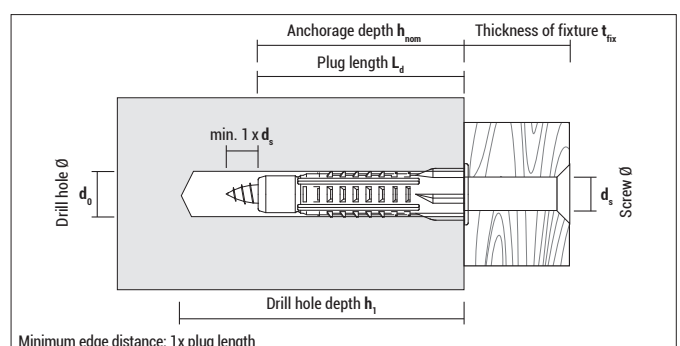
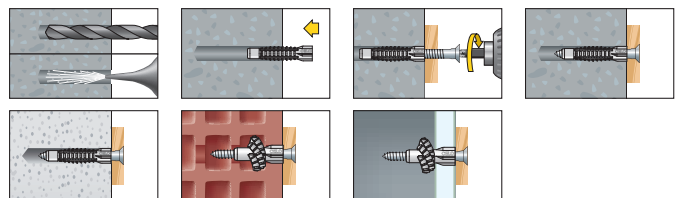

Multi-purpose plug MZ & MZK



MZ without collar

Type	Art-No	d ₀ [mm]	h ₁ ≥ [mm]	h _{nom} ≥ [mm]	L _d [mm]	h _{min} ¹ [mm]	d _s [mm]	€/ 100 pcs	[pcs]	[pcs]
MZ 6	96MZ	6	40	29	29	7	3 - 4,5		100	6.000
MZ 6x40	9640MZ	6	50	40	40	7	3 - 4,5		100	4.800
MZ 8	98MZ	8	60	48	48	9	4 - 6		100	1.800
MZ 10	910MZ	10	75	59	59	12	6 - 8		50	900
MZ 12	912MZ	12	90	75	75	15	8 - 10		50	600
MZ 14	914MZ	14	100	79	79	15	10 - 12		25	300

¹ Min. thickness of structural part or board (e. g. for applications in plasterboard)



MZK with collar

Type	Art-No	d ₀ [mm]	h ₁ ≥ [mm]	h _{nom} ≥ [mm]	L _d [mm]	h _{min} ¹ [mm]	d _s [mm]	€/ 100 pcs	[pcs]	[pcs]
MZK 6	96MZK	6	40	29	30	7	3 - 4,5		100	4.800
MZK 6x41	9641MZK	6	50	40	41	7	3 - 4,5		100	2.700
MZK 8	98MZK	8	60	48	49	9	4 - 6		100	1.800
MZK 10	910MZK	10	75	59	60	12	6 - 8		50	900
MZK 12	912MZK	12	90	75	76	15	8 - 10		50	600
MZK 14	914MZK	14	100	79	80	15	10 - 12		25	300

¹ Min. thickness of structural part or board (e. g. for applications in plasterboard)



MZK with collar, incl. PZ chipboard screw (MZK 6, 6-41 and 8) respectively hex-head wood screw (MZK 10)

Type	Art-No	d ₀ [mm]	h ₁ ≥ [mm]	h _{nom} ≥ [mm]	L _d [mm]	h _{min} ¹ [mm]	d _s x L _s ² [mm]	€/ 100 pcs	[pcs]	[pcs]
MZK 6 SPS	96MZKKSZ	6	40	29	30	7,0	4,5 x 45		50	2.400
MZK 6x41 SPS	9641MZKKSZ	6	50	40	41	7,0	4,5 x 50		50	1.350
MZK 8 SPS	98MZKKSZ	8	60	48	49	9,5	5,0 x 70		50	900
MZK 10 SKS	910MZKK	10	75	59	60	12,0	6,0 x 80		25	450

¹ Min. thickness of structural part or board (e. g. for applications in plasterboard)

² Screw length



MZK with collar, in round box

Type	Art-No	d ₀ [mm]	h ₁ ≥ [mm]	h _{nom} ≥ [mm]	L _d [mm]	h _{min} ¹ [mm]	d _s [mm]	€/ box	[pcs]	[boxes]
MZK 6x41	9641EXPMZK	6	50	40	41	7,0	3 - 4,5		200	10
MZK 8	98EXPMZK	8	60	48	49	9,5	4 - 6		90	10
MZK 10	910EXPMZK	10	75	59	60	12,0	6 - 8		50	10
MZK 12	912EXPMZK	12	90	75	76	15,0	8 - 10		25	10

¹ Min. thickness of structural part or board (e. g. for applications in plasterboard)



MZK Round box dispenser (empty); 44 x 56 x 30 cm (W x H x D)

Type	Art-No	€/ pcs	[pcs]
MZKxcover for round box dispenser	010507420	on request	1
Round box dispenser	010507411	on request	1
Hook for dispenser	010507441	on request	1

Multi-purpose plug MZ & MZK



Blister MZ without collar



Type	Art-No	d ₀ [mm]	h ₁ ≥ [mm]	h _{nom} ≥ [mm]	L _d [mm]	h _{min} ¹ [mm]	d _s [mm]	€ / Blister	[pcs]	[Blister]
MZ 6	56MZ20	6	40	29	29	7,0	3 - 4,5		20	10
MZ 6x40	5640MZ10	6	50	40	40	7,0	3 - 4,5		10	10
MZ 8	58MZ15	8	60	48	48	9,5	4 - 6		15	10
MZ 10	510MZ10	10	75	59	59	12,0	6 - 8		10	10
MZ 12	512MZ5	12	90	75	75	15,0	8 - 10		5	10

¹ Min. thickness of structural part or board (e. g. for applications in plasterboard)

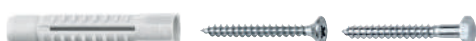

Blister MZ without collar, incl. screw



Type	Art-No	d ₀ [mm]	h ₁ ≥ [mm]	h _{nom} ≥ [mm]	L _d [mm]	h _{min} ¹ [mm]	d _s x L _s [mm]	Type of screw	€ / Blister	[pcs]	[Blister]
MZ 6 SPS	56MZSZ20	6	40	29	29	7,0	4,5 x 40			20	10
MZ 6x40 SPS	5640MZSZ10	6	50	40	40	7,0	4,5 x 50			10	10
MZ 8 SPS	58MZSZ8	8	60	48	48	9,5	5,0 x 70			8	10
MZ 10 SKS	510MZK5	10	75	59	59	12,0	6,0 x 80			5	10
MZ 12 SKS	512MZK2	12	90	75	75	15,0	8,0 x 90			2	10

¹ Min. thickness of structural part or board (e. g. for applications in plasterboard)



Blister MZK with collar



Type	Art-No	d ₀ [mm]	h ₁ ≥ [mm]	h _{nom} ≥ [mm]	L _d [mm]	h _{min} ¹ [mm]	d _s [mm]	€ / Blister	[pcs]	[Blister]
MZK 6	56MZK20	6	40	29	30	7,0	3 - 4,5		20	10
MZK 6x41	5641MZK10	6	50	40	41	7,0	3 - 4,5		10	10
MZK 8	58MZK15	8	60	48	49	9,5	4 - 6		15	10
MZK 10	510MZK10	10	75	59	60	12,0	6 - 8		10	10
MZK 12	512MZK5	12	90	75	76	15,0	8 - 10		5	10

¹ Min. thickness of structural part or board (e. g. for applications in plasterboard)



Blister MZK with collar, incl. screw



Type	Art-No	d ₀ [mm]	h ₁ ≥ [mm]	h _{nom} ≥ [mm]	L _d [mm]	h _{min} ¹ [mm]	d _s x L _s [mm]	Type of screw	€ / Blister	[pcs]	[Blister]
MZK 6 SPS	56MZKSZ20	6	40	29	30	7,0	4,5 x 45			20	10
MZK 6x41 SPS	5641MZKSZ10	6	50	40	41	7,0	4,5 x 50			10	10
MZK 6x41 WH	5641MZKWH5	6	50	40	41	7,0	4,5 x 52			5	10
MZK 6x41 RH	5641MZKRH5	6	50	40	41	7,0	4,5 x 68			5	10
MZK 8 SPS	58MZKSZ8	8	60	48	49	9,5	5,0 x 70			8	10
MZK 8 WH	58MZKWH5	8	60	48	49	9,5	5,0 x 70			5	10
MZK 8 RH	58MZKRH5	8	60	48	49	9,5	5,0 x 86			5	10
MZK 10 SKS	510MZKK5	10	75	59	60	12,0	6,0 x 80			5	10
MZK 12 SKS	512MZKK2	12	90	75	76	15,0	8,0 x 90			2	10

¹ Min. thickness of structural part or board (e. g. for applications in plasterboard)

Multi-purpose plug MZ & MZK



Assortment box MZK with screw (102 pieces in total)

Type	Art-No	Box contains	d _o [mm]	h ₁ ≥ [mm]	L _d [mm]	d _s x L _s [mm]	€/box	 [box]	Min. sales unit [pcs]
MZK	MIXMZKSZ102	30 Multi-purpose plug MZK 6 incl. SPS 4,5x45 V, Pozi 15 Multi-purpose plug MZK 8 incl. SPS 5,0x60 V, Pozi 6 Multi-purpose plug MZK 10 incl. SKS 6,0x80 DIN 571	6 8 10	40 60 75	30 49 60	4,5 x 45 5,0 x 60 6,0 x 80		1	5

Packed in robust plastic box



Assortment box MZK and F without screw (156 pieces in total)

Type	Art-No	Box contains	d _o [mm]	h ₁ ≥ [mm]	L _d [mm]	d _s [mm]	€/box	 [box]	Min. sales unit [pcs]
MZK and F	MIXNFMZK156	30 Multi-purpose plug MZK 6 15 Multi-purpose plug MZK 8 6 Multi-purpose plug MZK 10 60 Standard plug F 5 30 Standard plug F 6 15 Standard plug F 8	6 8 10 5 6 8	40 60 75 35 40 55	30 49 60 25 30 40	3,0 - 4,5 4,0 - 6,0 6,0 - 8,0 2,5 - 4,0 3,5 - 5,0 4,5 - 6,0		1	5

Packed in robust plastic box

Loads for wood screws F_{rec} for the largest applicable screw diameter and full anchorage depth

Type	Screw Ø d _s [mm]	Concrete F _{rec} [kN]	Solid sand-lime brick KS 12 F _{rec} [kN]	Solid brick Mz 12 F _{rec} [kN]	Aerated concrete AAC2 F _{rec} [kN]	Aerated concrete AAC4 F _{rec} [kN]	Hollow brick HLz 12 F _{rec} [kN]	Plasterboard 12,5 mm F _{rec} [kN]	Chipboard 16 mm F _{rec} [kN]
MZ/MZK 6	4,5	0,30	0,26	0,16	0,04	0,06	0,22	0,06	0,21
MZ/MZK 6x41	4,5	0,52	0,51	0,27	0,06	0,12	0,21	0,08	0,15
MZ/MZK 8	6	0,72	0,59	0,43	0,11	0,14	0,27	0,09	0,23
MZ/MZK 10	8	1,56	1,07	0,68	0,13	0,25	0,31	0,08	0,25
MZ/MZK 12	10	2,02	1,31	–	0,23	0,39	0,42	0,11	0,37
MZ/MZK 14	12	2,27	–	–	0,37	0,59	0,33	0,09	0,30

F_{rec}: Recommended loads incl. safety factor of 7

Loads for chipboard screws F_{rec} for the largest applicable screw diameter and full anchorage depth

Type	Screw Ø d _s [mm]	Concrete F _{rec} [kN]	Solid sand-lime brick KS 12 F _{rec} [kN]	Solid brick Mz 12 F _{rec} [kN]	Aerated concrete AAC2 F _{rec} [kN]	Aerated concrete AAC4 F _{rec} [kN]	Hollow brick HLz 12 F _{rec} [kN]	Plasterboard 12,5 mm F _{rec} [kN]	Chipboard 16 mm F _{rec} [kN]
MZ/MZK 6	4,5	0,06	0,06	0,05	0,02	0,03	0,08	0,03	0,14
MZ/MZK 6x41	4,5	0,17	0,15	0,08	0,04	0,05	0,17	0,09	0,21
MZ/MZK 8	6	0,24	0,24	0,21	0,06	0,10	0,26	0,09	0,29
MZ/MZK 10 ¹	6	0,17	0,17	0,16	0,07	0,12	0,35	0,10	0,29

F_{rec}: Recommended loads incl. safety factor of 7

¹ Load values apply to chipboard screws with Ø 6

Universal plug AZ & AZK

Advantages



Universal plug AZ



Universal plug AZK with collar

- Suitable for nearly all building materials. In solid building materials the plug's body expands against the drill hole. In perforated building materials, plasterboards, etc. the plug knots
- Usable with wood screws and chipboard screws with different diameters
- High-quality polyethylene guarantees long-lasting elasticity and consequently no brittle breaks, even after years

Suitable building materials

Very suitable



- Concrete
- Natural stone
- Solid brick
- Solid sand-lime brick
- Lightweight solid concrete blocks
- Aerated concrete
- Gypsum blocks
- Hollow brick
- Hollow sand-lime brick
- Lightweight hollow concrete blocks
- Plasterboard/ Fibreboard
- Chipboard



Approvals and certificates



Mounting

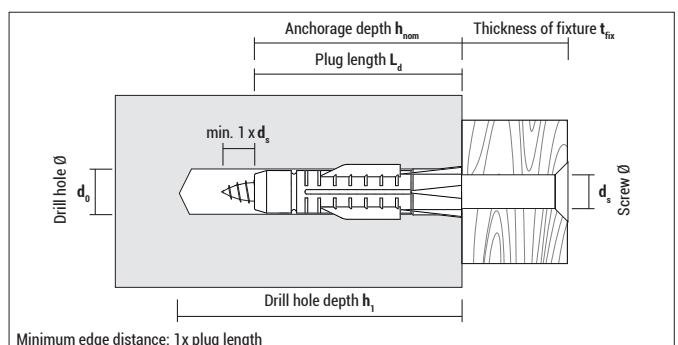
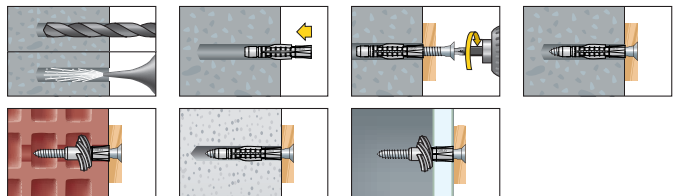

Universal plug AZ & AZK



AZ without collar

Type	Art-No	d ₀ [mm]	h ₁ ≥ [mm]	h _{nom} ≥ [mm]	L _d [mm]	h _{min} ¹ [mm]	d _s [mm]	€/100 pcs	[pcs]	[pcs]
AZ 5	95AZ	5	40	30	30	7,0	3 - 4		100	4.800
AZ 6	96AZ	6	50	35	35	9,5	4 - 5		100	4.800
AZ 8	98AZ	8	60	50	50	12,5	5 - 6		100	1.800
AZ 10	910AZ	10	75	60	60	15,0	7 - 8		50	900
AZ 12	912AZ	12	85	70	70	18,0	8 - 10		25	450

¹ Min. thickness of structural part or board (e. g. for applications in plasterboard)



AZK with collar

Type	Art-No	d ₀ [mm]	h ₁ ≥ [mm]	h _{nom} ≥ [mm]	L _d [mm]	h _{min} ¹ [mm]	d _s [mm]	€/100 pcs	[pcs]	[pcs]
AZK 5	95AZK	5	40	30	31	7,0	3 - 4		100	4.800
AZK 6	96AZK	6	50	35	36	9,5	4 - 5		100	2.700
AZK 8	98AZK	8	60	50	51	12,5	5 - 6		100	1.800
AZK 10	910AZK	10	75	60	61	15,0	7 - 8		50	900
AZK 12	912AZK	12	85	70	71	18,0	8 - 10		25	450

¹ Min. thickness of structural part or board (e. g. for applications in plasterboard)

Loads for wood screws F_{rec} for the largest applicable screw diameter and full anchorage depth

Type	Screw Ø _s [mm]	Concrete F _{rec} [kN]	Solid brick KS 12 / Solid brick Mz 12 F _{rec} [kN]	Aerated concrete AAC2 F _{rec} [kN]	Hollow sand- lime brick KSL 12 F _{rec} [kN]	Hollow sand- lime brick HLz 12 F _{rec} [kN]	Hollow brick Poroton T12 F _{rec} [kN]	Plasterboard 12,5 mm F _{rec} [kN]	Plasterboard 2 x 12,5 mm F _{rec} [kN]
AZ/AZK 5	4	0,16	0,16	0,03	0,17	0,21	0,10	0,07	–
AZ/AZK 6	5	0,23	0,19	0,05	0,34	0,23	0,13	0,09	–
AZ/AZK 8	6	0,46	0,27	0,06	0,31	0,32	0,15	0,09	–
AZ/AZK 10	8	1,25	0,86	0,11	0,52	0,31	0,19	0,09	0,17
AZ/AZK 12	10	1,47	0,91	0,20	0,48	0,35	0,25	–	0,22

F_{rec}: Recommended loads incl. safety factor of 7

Loads for chipboard screws F_{rec} for the largest applicable screw diameter and full anchorage depth

Type	Screw Ø _s [mm]	Concrete F _{rec} [kN]	Solid brick KS 12 / Solid brick Mz 12 F _{rec} [kN]	Aerated concrete AAC2 F _{rec} [kN]	Hollow sand- lime brick KSL 12 F _{rec} [kN]	Hollow brick HLz 12 F _{rec} [kN]	Hollow brick Poroton T12 F _{rec} [kN]	Plasterboard 12,5 mm F _{rec} [kN]	Plasterboard 2 x 12,5 mm F _{rec} [kN]
AZ/AZK 5	4	0,07	0,12	0,02	0,15	0,24	0,14	0,06	–
AZ/AZK 6	5	0,11	0,12	0,05	0,30	0,27	0,12	0,08	–
AZ/AZK 8	6	0,16	0,18	0,07	0,34	0,22	0,13	0,09	–

F_{rec}: Recommended loads incl. safety factor of 7

Aerated concrete plug

GB

Advantages



- Specialised plug with excellent pull out loads in aerated concrete
- Once the screw has been screwed in, the expansion force is transferred over three flanks optimally by developing a type of undercut
- All CELO aerated concrete plugs can also be hammered into a smaller drill hole in AAC4 aerated concrete; generally even without pre-drilling in AAC2
- The GB should be used together with wood screws

Suitable building materials

Very suitable



- Aerated concrete
- Gypsum blocks



Approvals and certificates



Mounting

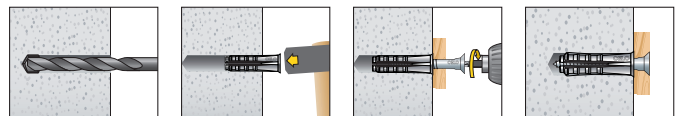

Aerated concrete plug GB

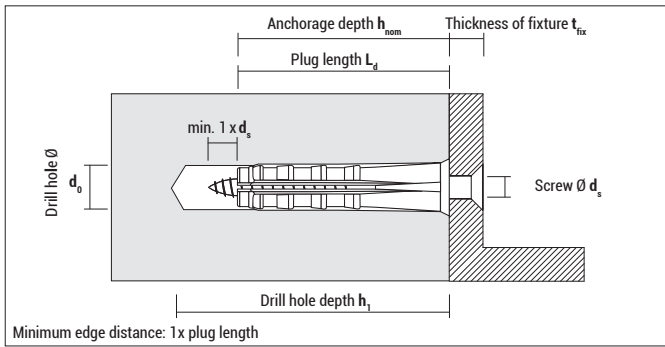

GB

Type	Art-No	d_0^* [mm]	$h_1 \geq$ [mm]	$h_{nom} \geq$ [mm]	L_d [mm]	d_s [mm]	€/ 100 pcs	[pcs]	[pcs]
GB 10	910GB	10	65	55	55	4,5 - 6		25	675
GB 12	912GB	12	70	60	60	7 - 8		20	540
GB 14	914GB	14	90	75	75	10		10	270

* All GB sizes can be hammered into a smaller drill hole when used in aerated concrete AAC4, in AAC2 usually without pre-drilling



Blister GB without screw

Type	Art-No	d_0^* [mm]	$h_1 \geq$ [mm]	$h_{nom} \geq$ [mm]	L_d [mm]	d_s [mm]	€/ Blister	[pcs]	[Blister]
GB 10	510GB4	10	65	55	55	4,5 - 6		4	10
GB 12	512GB4	12	70	60	60	7 - 8		4	10

* All GB sizes can be hammered into a smaller drill hole when used in aerated concrete AAC4, in AAC2 usually without pre-drilling

Loads F_{rec}

Type	Wood screw-Ø [mm]	Aerated concrete AAC2		Aerated concrete AAC4	
		F_{rec} [kN]	F_{rec} [kN]	F_{rec} [kN]	F_{rec} [kN]
GB 10	6	0,25	0,55		
GB 12	7	0,33	0,66		
GB 14	10	0,50	1,10		

F_{rec} : Recommended loads incl. safety factor of 6

Spacing and edge distance for GB 12 according to former German approval by DIBt

Type	Spacing $a \geq$		Edge distance $a_1 \geq$		Min. thickness of structural part d [mm]
	PB2 / AAC2 [mm]	\geq PB4 / AAC4 [mm]	PB2 / AAC2 [mm]	\geq PB4 / AAC4 [mm]	
GB 12	150	200	100	150	120

Scaffold plug GR



Advantages

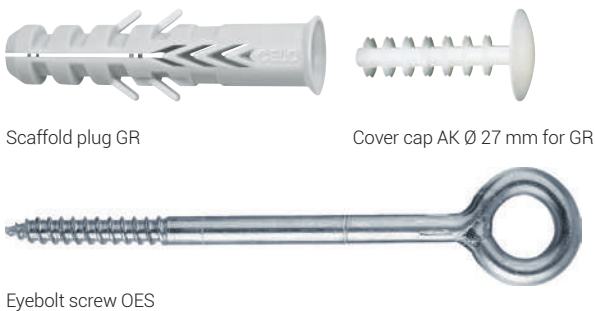

Scaffold plug GR

Cover cap AK Ø 27 mm for GR

Eyebolt screw OES

- Specialised plug for all scaffold installations in solid building materials in according to DIN 4420 and the guidelines of the German professional construction associations
- Nylon Plug GR matches optimally with the eyebolt OES for high pull out loads
- Markings on the eyebolt screw help to screw in the screw with the correct depth
- Cover cap AK to seal the plug (UV stabilized)

Approvals and certificates



Suitable building materials

Very suitable



- Concrete
- Natural stone
- Solid brick
- Solid sand-lime brick

Suitable to a limited extent



- Hollow brick
- Hollow sand-lime brick
- Lightweight hollow concrete blocks

Mounting

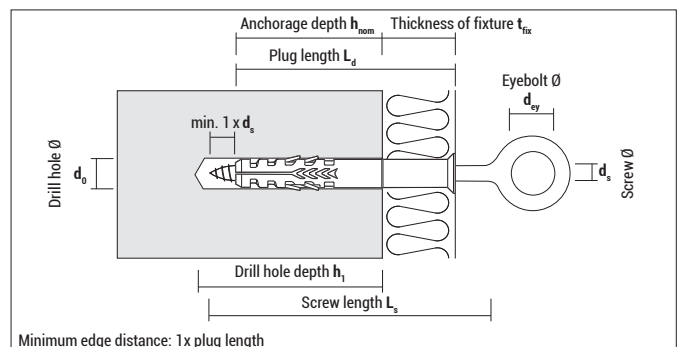
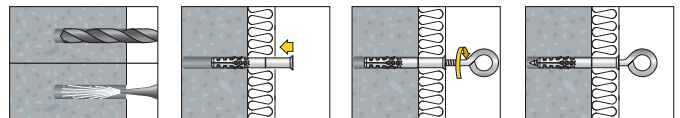

Scaffold plug GR



GR

Type	Art-No	d_0 [mm]	$h_1 \geq$ [mm]	$h_{nom} \geq$ [mm]	L_d [mm]	d_s [mm]	$t_{fix} \leq$ [mm]	€ / 100 pcs	[pcs]	[pcs]
GR 14x70	91470GR	14	90	70	70	12	0		40	320
GR 14x100	914100GR	14	90	70	100	12	30		40	320
GR 14x135	914135GR	14	90	70	135	12	65		40	320
GR 14x185	914185GR	14	90	70	185	12	115		40	320



OES, zinc plated

Type	Art-No	d_s [mm]	L_s [mm]	d_{ey} [mm]	€ / 100 pcs	[pcs]	[pcs]
OES 12x90	91290OES	12	90	23		20	60
OES 12x120	912120OES	12	120	23		20	60
OES 12x160	912160OES	12	160	23		20	60
OES 12x190	912190OES	12	190	23		20	60
OES 12x230	912230OES	12	230	23		20	60
OES 12x300	912300OES	12	300	23		20	60
OES 12x350	912350OES	12	350	23		20	60



AK Cover cap Ø 27 mm for GR

Type	Art-No	Suitable for d_s [mm]	Length L_d [mm]	€ / 100 pcs	[pcs]	[pcs]
AK	91AKGR	GR 14	53		50	600

Loads F_{rec} and F_{eff} using eyebolt screws OES Ø 12

Type	Concrete C20/25		Solid brick Mz 12		Solid sand-lime brick KS 12	
	F_{rec} [kN]	F_{eff} [kN]	F_{rec} [kN]	F_{eff} [kN]	F_{rec} [kN]	F_{eff} [kN]
GR 14	3,0	12,2	2,8	11,0	3,0	12,2

F_{rec} : Recommended loads incl. safety factor of 4

F_{eff} : Effective pull out loads / ultimate loads excl. safety factors

Blockwork anchor MSD



Advantages



- Suitable for fastening water pipes with pipe clamps using wood screws and chipboard screws
- When used with hanger bolts, the metal blockwork anchor MSD complies the technical guidelines for gas pipe installations (TRGI 3.3.7.2.)
- Toothed surface provides a secure grip in different base materials

Suitable building materials

Very suitable



- Concrete
- Natural stone
- Solid brick
- Solid sand-lime brick
- Lightweight solid concrete blocks
- Aerated concrete
- Gypsum blocks
- Hollow brick
- Hollow sand-lime brick
- Lightweight hollow concrete blocks



MSD

Type	Art-No	d_0 [mm]	$h_1 \geq$ [mm]	$h_{nom} \geq$ [mm]	L_d [mm]	d_s [mm]	€ / 100 pcs	[pcs]	[pcs]
MSD 6x32	9B632MSD	7 - 9*	38	32	32	5 - 6		100	2.000
MSD 8x38	9B838MSD	10 - 12*	46	38	38	6 - 8		100	2.000
MSD 8x60	9B860MSD	10 - 12*	68	60	60	6 - 8		50	1.000

* Depending on building material, see following table "Loads"

Loads F_{rec} at largest applicable screw diameter and full anchorage depth

Type	Concrete		Solid sand-lime brick		Solid stone Mz 12		Aerated concrete AAC2		Aerated concrete AAC4		Lightweight solid concrete blocks		Hollow brick HLz 12	
	d_0 [mm]	F_{rec} [kN]	d_0 [mm]	F_{rec} [kN]	d_0 [mm]	F_{rec} [kN]	d_0 [mm]	F_{rec} [kN]	d_0 [mm]	F_{rec} [kN]	d_0 [mm]	F_{rec} [kN]	d_0 [mm]	F_{rec} [kN]
MSD 6x32	9	0,25	8	0,20	8	0,20	without	0,10	7	0,20	5	0,15	7	0,15
MSD 8x38	12	0,30	11	0,30	11	0,30	without	0,20	10	0,35	6	0,20	10	0,25
MSD 8x60	12	0,55	11	0,50	11	0,50	6	0,30	10	0,45	6	0,30	10	0,30





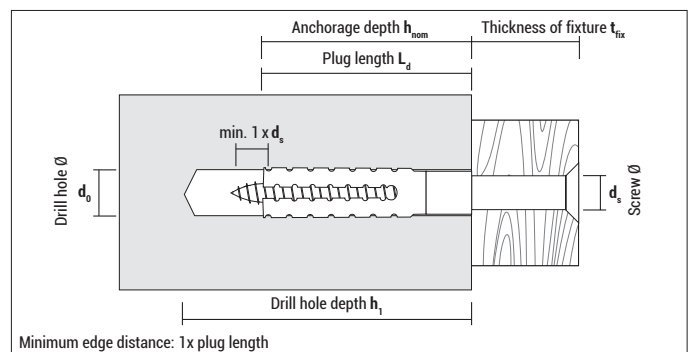
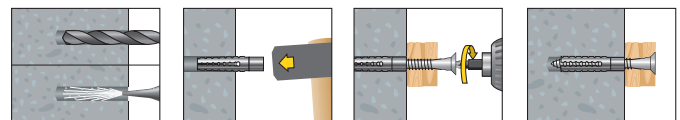

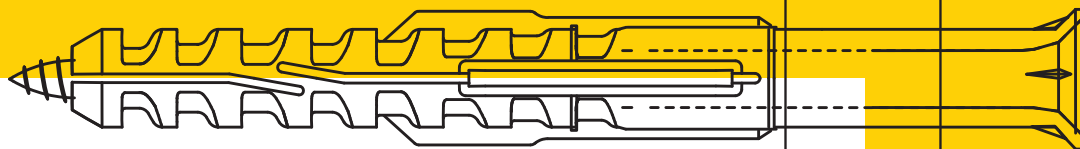

F_{rec} : Recommended loads in all directions incl. safety factor of 6

Mounting





Frame Fixings

MFR		43
HBR		48
NP		50
USN		53
NPZ		55
BN		56
BDN		56
DP		58

Multifunction frame plug MFR



Advantages



SB TX, zinc plated / A4 / HD



SB SSKS, zinc plated / A4 / HD



FB SSKS, zinc plated / A4



- The multifunction frame plug MFR enables universal mounting of façade substructures as well as wood and metal parts in all common base materials
- The long expansion area and early expansion achieved by lateral bars ensure reliable and secure hold
- Approved by company Hörmann for fire protection doors in solid base materials
- MFR 8: setting depth 50 mm; MFR 10: setting depth 50 mm and 70 mm
- The flat rim version prevents contact corrosion
- Almost all lengths are pre-assembled
- Also suitable for precast pre-stressed concrete hollow core slabs
- Suitable for windows and door frames installations

Suitable building materials

Very suitable



- Concrete
- Solid brick
- Solid sand-lime brick
- Precast pre-stressed hollow core slabs
- Aerated concrete
- Hollow brick
- Hollow sand-lime brick
- Lightweight hollow concrete blocks
- Natural stone
- Lightweight solid concrete blocks

Approvals and certificates

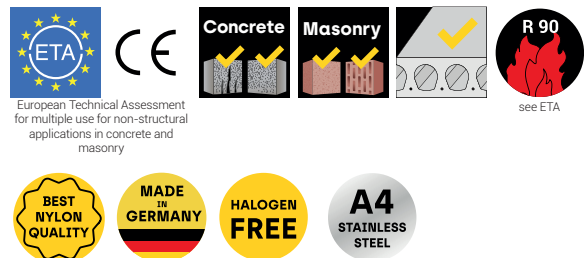

Mounting

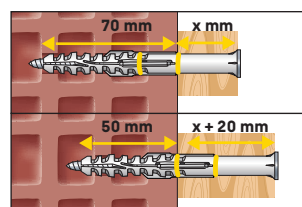
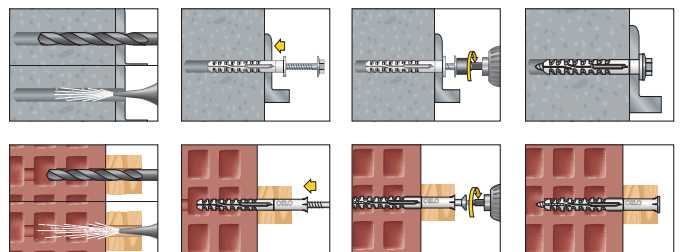

MFR 10:
Two setting depths
(50 and 70 mm)

Multifunction frame plug MFR

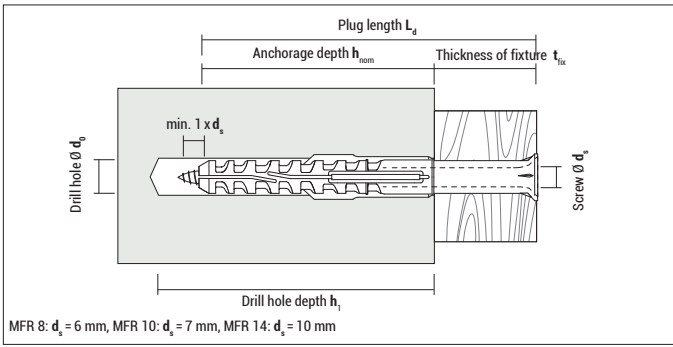

MFR SB TX, zinc plated countersunk plug with countersunk screw

Type	Art-No	d_0 [mm]	$h_1 \geq$ [mm]	$h_{nom} \geq$ [mm]	L_d [mm]	$t_{fix} \leq$ [mm]	Recess	ETA	€/ 100 pcs	[pcs]	[pcs]
8x60	9860MFRST	8	60	50	60	10	TX 30	●		100	800
8x80	9880MFRST	8	60	50	80	30	TX 30	●		100	800
8x100	98100MFRST	8	60	50	100	50	TX 30	●		50	400
8x120	98120MFRST	8	60	50	120	70	TX 30	●		50	400
8x140 ¹⁾	98140MFRST	8	60	50	140	90	TX 30	●		50	400
10x60	91060MFRST	10	60	50	60	10	TX 40	●		50	400
10x80	91080MFRST	10	60/80	50/70	80	30/10	TX 40	●		50	400
10x100	910100MFRST	10	60/80	50/70	100	50/30	TX 40	●		50	400
10x115	910115MFRST	10	60/80	50/70	115	65/45	TX 40	●		50	400
10x135	910135MFRST	10	60/80	50/70	135	85/65	TX 40	●		50	400
10x160	910160MFRST	10	60/80	50/70	160	110/90	TX 40	●		50	400
10x180	910180MFRST	10	60/80	50/70	180	130/110	TX 40	●		50	200
10x200	910200MFRST50	10	60/80	50/70	200	150/130	TX 40	●		50	200
10x240	910240MFRST50	10	60/80	50/70	240	190/170	TX 40	●		50	200
10x280	910280MFRST50	10	60/80	50/70	280	230/210	TX 40	●		50	-
10x320	910320MFRST50	10	60/80	50/70	320	270/250	TX 40	●		50	-
14x80	91480MFRST	14	85	70	80	10	TX 50	●		25	200
14x110	914110MFRST	14	85	70	110	40	TX 50	●		25	200
14x140	914140MFRST	14	85	70	140	70	TX 50	●		25	200
14x170*	914170MFRST	14	85	70	170	100	TX 50	●		25	200
14x200*	914200MFRST	14	85	70	200	130	TX 50	●		25	100
14x230*	914230MFRST	14	85	70	230	160	TX 50	●		25	100
14x270*	914270MFRST	14	85	70	270	200	TX 50	●		25	100

* not pre-assembled

¹⁾ Available from december 2024



MFR SB TX, stainless steel A4 countersunk plug with countersunk screw



Type	Art-No	d_0 [mm]	$h_1 \geq$ [mm]	$h_{nom} \geq$ [mm]	L_d [mm]	$t_{fix} \leq$ [mm]	Recess	ETA	€/ 100 pcs	[pcs]	[pcs]
8x60 A4	9X860MFRST	8	60	50	60	10	TX30	●		100	800
8x80 A4	9X880MFRST	8	60	50	80	30	TX 30	●		100	800
8x100 A4	9X8100MFRST	8	60	50	100	50	TX 30	●		50	400
10x60 A4	9X1060MFRST	10	60	50	60	10	TX40	●		50	400
10x80 A4	9X1080MFRST	10	60/80	50/70	80	30/10	TX 40	●		50	400
10x100 A4	9X10100MFRST	10	60/80	50/70	100	50/30	TX 40	●		50	400
10x115 A4	9X10115MFRST	10	60/80	50/70	115	65/45	TX 40	●		50	400
10x135 A4	9X10135MFRST	10	60/80	50/70	135	85/65	TX 40	●		50	400
10x160 A4	9X10160MFRST	10	60/80	50/70	160	110/90	TX 40	●		50	400
10x180 A4	9X10180MFRST	10	60/80	50/70	180	130/110	TX 40	●		50	200
10x200 A4	9X10200MFRST	10	60/80	50/70	200	150/130	TX 40	●		50	200



MFR SB TX, hot-dip galvanized countersunk plug with countersunk screw

Type	Art-No	d ₀ [mm]	h ₁ ≥ [mm]	h _{nom} ≥ [mm]	L _d [mm]	t _{fix} ≤ [mm]	Recess	€ / 100 pcs	[pcs]	[pcs]
10x100 HD	9HD10100MFRST	10	60 / 80	50 / 70	100	50 / 30	TX 40		50	400
10x135 HD	9HD10135MFRST	10	60 / 80	50 / 70	135	85 / 65	TX 40		50	400
10x160 HD	9HD10160MFRST	10	60 / 80	50 / 70	160	110 / 90	TX 40		50	400

Hot-dip galvanized is not part of the ETA assessment



MFR SB SSKS, zinc plated countersunk plug, hex-head screw with integral washer

Type	Art-No	d ₀ [mm]	h ₁ ≥ [mm]	h _{nom} ≥ [mm]	L _d [mm]	t _{fix} ≤ [mm]	Recess		€ / 100 pcs	[pcs]	[pcs]
8x60	9860MFRSB	8	60	50	60	10	SW10/TX 30	●		100	800
8x80	9880MFRSB	8	60	50	80	30	SW10/TX 30	●		100	800
8x100	98100MFRSB	8	60	50	100	50	SW10/TX 30	●		50	400
8x120	98120MFRSB	8	60	50	120	70	SW10/TX 30	●		50	400
8x140 ¹⁾	98140MFRSB	8	60	50	140	90	SW10/TX 30	●		50	400
10x60	91060MFRSB	10	60	50	60	10	SW13/TX 40	●		50	400
10x80	91080MFRSB	10	60 / 80	50 / 70	80	30 / 10	SW13/TX 40	●		50	400
10x100	910100MFRSB	10	60 / 80	50 / 70	100	50 / 30	SW13/TX 40	●		50	400
10x115	910115MFRSB	10	60 / 80	50 / 70	115	65 / 45	SW13/TX 40	●		50	400
10x135	910135MFRSB	10	60 / 80	50 / 70	135	85 / 65	SW13/TX 40	●		50	400
10x160	910160MFRSB	10	60 / 80	50 / 70	160	110 / 90	SW13/TX 40	●		50	400
10x180	910180MFRSB	10	60 / 80	50 / 70	180	130 / 110	SW13/TX 40	●		50	200
10x200	910200MFRSB50	10	60 / 80	50 / 70	200	150 / 130	SW13/TX 40	●		50	200
10x240	910240MFRSB50	10	60 / 80	50 / 70	240	190 / 170	SW13/TX 40	●		50	200
10x280	910280MFRSB50	10	60 / 80	50 / 70	280	230 / 210	SW13/TX 40	●		50	–
10x320	910320MFRSB50	10	60 / 80	50 / 70	320	270 / 250	SW13/TX 40	●		50	–
14x80	91480MFRSB	14	85	70	80	10	SW17/TX 50	●		25	200
14x110	914110MFRSB	14	85	70	110	40	SW17/TX 50	●		25	200
14x140	914140MFRSB	14	85	70	140	70	SW17/TX 50	●		25	200
14x170*	914170MFRSB	14	85	70	170	100	SW17/TX 50	●		25	200
14x200*	914200MFRSB	14	85	70	200	130	SW17/TX 50	●		25	100
14x230*	914230MFRSB	14	85	70	230	160	SW17/TX 50	●		25	100
14x270*	914270MFRSB	14	85	70	270	200	SW17/TX 50	●		25	100

* not pre-assembled

¹⁾ Available from december 2024



MFR SB SSKS, stainless steel A4 countersunk plug, hex-head screw with integral washer



Type	Art-No	d ₀ [mm]	h ₁ ≥ [mm]	h _{nom} ≥ [mm]	L _d [mm]	t _{fix} ≤ [mm]	Recess		€ / 100 pcs	[pcs]	[pcs]
8x60 A4	9X860MFRSB	8	60	50	60	10	SW10/TX 30	●		100	800
8x80 A4	9X880MFRSB	8	60	50	80	30	SW10/TX 30	●		100	800
8x100 A4	9X8100MFRSB	8	60	50	100	50	SW10/TX 30	●		50	400
10x60 A4	9X1060MFRSB	10	60	50	60	10	SW13/TX 40	●		50	400
10x80 A4	9X1080MFRSB	10	60 / 80	50 / 70	80	30 / 10	SW13/TX 40	●		50	400
10x100 A4	9X10100MFRSB	10	60 / 80	50 / 70	100	50 / 30	SW13/TX 40	●		50	400
10x115 A4	9X10115MFRSB	10	60 / 80	50 / 70	115	65 / 45	SW13/TX 40	●		50	400
10x135 A4	9X10135MFRSB	10	60 / 80	50 / 70	135	85 / 65	SW13/TX 40	●		50	400
10x160 A4	9X10160MFRSB	10	60 / 80	50 / 70	160	110 / 90	SW13/TX 40	●		50	400
10x180 A4	9X10180MFRSB	10	60 / 80	50 / 70	180	130 / 110	SW13/TX 40	●		50	200
10x200 A4	9X10200MFRSB	10	60 / 80	50 / 70	200	150 / 130	SW13/TX 40	●		50	200



MFR SB SSKS, hot-dip galvanized countersunk plug, hex-head screw with integral washer

Type	Art-No	d ₀ [mm]	h ₁ ≥ [mm]	h _{nom} ≥ [mm]	L _d [mm]	t _{fix} ≤ [mm]	Recess	€ / 100 pcs	[pcs]	[pcs]
10x100 HD	9HD10100MFRSB	10	60 / 80	50 / 70	100	50 / 30	SW13/TX 40		50	400
10x135 HD	9HD10135MFRSB	10	60 / 80	50 / 70	135	85 / 65	SW13/TX 40		50	400
10x160 HD	9HD10160MFRSB	10	60 / 80	50 / 70	160	110 / 90	SW13/TX 40		50	400

Hot-dip galvanized is not part of the ETA assessment

Multifunction frame plug MFR



washer-Ø MFR 8: 17 mm; MFR 10: 19 mm; MFR 14: 22 mm

MFR FB SSKS, zinc plated flat rim plug, hex-head screw with integral washer

Type	Art-No	d ₀ [mm]	h ₁ ≥ [mm]	h _{nom} ≥ [mm]	L _d [mm]	t _{fix} ≤ [mm]	Recess	ETA	€/100 pcs	[pcs]	[pcs]
8x60	9860MFRFB	8	60	50	60	10	SW10/TX 30	●		100	800
8x80	9880MFRFB	8	60	50	80	30	SW10/TX 30	●		100	800
10x60	91060MFRFB	10	60	50	60	10	SW13/TX 40	●		50	400
10x80	91080MFRFB	10	60/80	50/70	80	30/10	SW13/TX 40	●		50	400
10x100	910100MFRFB	10	60/80	50/70	100	50/30	SW13/TX 40	●		50	400
10x115	910115MFRFB	10	60/80	50/70	115	65/45	SW13/TX 40	●		50	400
10x135	910135MFRFB	10	60/80	50/70	135	85/65	SW13/TX 40	●		50	400
14x80	91480MFRFB	14	85	70	80	10	SW17/TX 50	●		25	200
14x110	914110MFRFB	14	85	70	110	40	SW17/TX 50	●		25	200
14x140	914140MFRFB	14	85	70	140	70	SW17/TX 50	●		25	200



washer-Ø MFR 8: 17 mm; MFR 10: 19 mm

MFR FB SSKS, stainless steel A4 flat rim plug, hex-head screw with integral washer



Type	Art-No	d ₀ [mm]	h ₁ ≥ [mm]	h _{nom} ≥ [mm]	L _d [mm]	t _{fix} ≤ [mm]	Recess	ETA	€/100 pcs	[pcs]	[pcs]
8x60 A4	9X860MFRFB	8	60	50	60	10	SW10/TX 30	●		100	800
8x80 A4	9X880MFRFB	8	60	50	80	30	SW10/TX 30	●		100	800
10x60 A4	9X1060MFRFB	10	60	50	60	10	SW13/TX 40	●		50	400
10x80 A4	9X1080MFRFB	10	60/80	50/70	80	30/10	SW13/TX 40	●		50	400
10x100 A4	9X10100MFRFB	10	60/80	50/70	100	50/30	SW13/TX 40	●		50	400
10x115 A4	9X10115MFRFB	10	60/80	50/70	115	65/45	SW13/TX 40	●		50	400
10x135 A4	9X10135MFRFB	10	60/80	50/70	135	85/65	SW13/TX 40	●		50	400



head-Ø MFR 8: 11 mm; MFR 10: 14 mm

Blister MFR SB TX, zinc plated Countersunk plug with countersunk screw



Type	Art-No	d ₀ [mm]	h ₁ ≥ [mm]	h _{nom} ≥ [mm]	L _d [mm]	t _{fix} ≤ [mm]	Recess	Type of screw	ETA	€/Blister	[pcs]	[Blister]
8x60	5860MFRST4	8	60	50	60	10	TX 30		●		4	10
8x80	5880MFRST4	8	60	50	80	30	TX 30		●		4	10
10x60	51060MFRST4	10	60	50	60	10	TX 40		●		4	10
10x80	51080MFRST4	10	60/80	50/70	80	30/10	TX 40		●		4	10
10x100	510100MFRST4	10	60/80	50/70	100	50/30	TX 40		●		4	10
10x115	510115MFRST4	10	60/80	50/70	115	65/45	TX 40		●		4	10
10x135	510135MFRST4	10	60/80	50/70	135	85/65	TX 40		●		4	10
10x160	510160MFRST4	10	60/80	50/70	160	110/90	TX 40		●		4	10



washer-Ø MFR 8: 17 mm; MFR 10: 19 mm

Blister MFR SB SSKS, zinc plated

Countersunk plug, hex-head screw with integral washer



Type	Art-No	d ₀ [mm]	h ₁ ≥ [mm]	h _{nom} ≥ [mm]	L _d [mm]	t _{fix} ≤ [mm]	Recess	Type of screw	ETA	€/Blister	[pcs]	[Blister]
8x60	5860MFRSB4	8	60	50	60	10	SW10/TX 30		●		4	10
10x80	51080MFRSB4	10	60/80	50/70	80	30/10	SW13/TX 40		●		4	10
10x100	510100MFRSB4	10	60/80	50/70	100	50/30	SW13/TX 40		●		4	10
10x115	510115MFRSB4	10	60/80	50/70	115	65/45	SW13/TX 40		●		4	10
10x135	510135MFRSB4	10	60/80	50/70	135	85/65	SW13/TX 40		●		4	10
10x160	510160MFRSB4	10	60/80	50/70	160	110/90	SW13/TX 40		●		4	10

Multifunction frame plug MFR



washer-Ø MFR 8: 17 mm; MFR 10: 19 mm



Blister MFR FB SSKS, zinc plated flat rim plug, hex-head screw with integral washer

Type	Art-No	d ₀ [mm]	h ₁ ≥ [mm]	h _{nom} ≥ [mm]	L _d [mm]	t _{fix} ≤ [mm]	Recess	Type of screw	ETA	€/ Blister	[pcs]	[Blister]
8x80	5880MFRFB4	8	60	50	80	30	SW10/TX 30				4	10
10x60	51060MFRFB4	10	60	50	60	10	SW13/TX 40				4	10

Loads MFR F_{per}

Type	Anchorage depth h _{nom} [mm]	Concrete		Solid brick		Solid sand-lime brick		Hollow brick HLz 12 F _{per} [kN]	Hollow sand-lime brick KSL 12 F _{per} [kN]	Hollow concrete block Hbn 25 F _{per} [kN]	Aerated concrete			Precast pre-stressed hollow core slabs C45/55 N _{per} [kN]	Permissible bending moment for zinc plated screws M _{per} [Nm]
		N _{per} [kN]	V _{per} [kN]	Mz 10 F _{per} [kN]	Mz 20 F _{per} [kN]	KS 10 F _{per} [kN]	KS 20 F _{per} [kN]				AAC2 F _{per} [kN]	AAC4 F _{per} [kN]	AAC6 F _{per} [kN]		
MFR 8	50	0,99	4,61	0,26	0,43	0,57	0,86	0,14	0,21	0,34	0,11	0,43	0,71	1,39	8,05
MFR 10	50	0,99	4,86	0,57	0,86	0,71	1,14	0,34	0,43	0,71	–	–	–	0,79	8,74
MFR 10	70	1,59	6,32	0,86	1,29	0,86	1,29	0,34	0,43	0,57	0,18	0,54	1,07	0,48	12,98
MFR 14	70	1,79	8,69	0,86	1,29	0,86	1,29	0,21	0,34	–	0,11	0,43	0,71	–	20,97

F_{per} = Permissible load in all directions, N_{per} = permissible tension load, V_{per} = permissible shear load according to ETA assessment for zinc plated screws. Load figures include the resistances' partial safety factors as per ETA assessments and a partial safety factor on the action of v_F = 1,4.

(For MFR with hot-dip galvanized screw. These values can be used as recommended loads).

Values apply to an average temperature range in the wall of max. + 24° C (temporarily + 40° C).

If the sustained average temperature is +50° C (temporarily +80° C) load capacities are reduced. In this case, refer to the assessment.

For further information regarding masonry (brick types and sizes) please refer to the assessment.

Spacing and edge distance

Type	Anchorage depth h _{nom} [mm]	Distances	Concrete ≥ C16/20 [mm]	Solid brick Mz/ Solid brick KS		Hollow brick HLz/ Hollow sand-lime brick KSL		Aerated concrete					
				single plug [mm]	group of plugs [mm]	single plug [mm]	group of plugs [mm]	AAC2		AAC4		AAC6	
								single plug [mm]	group of plugs [mm]	single plug [mm]	group of plugs [mm]	single plug [mm]	group of plugs [mm]
MFR 8	50	Spacing a / s _{2,min} parallel to edge	50	250	400	250	400	250	400	250	400	250	400
MFR 10	50		50	250	400	250	200	–	–	–	–	–	–
MFR 10	70		50	250	400	250	400	250	200	250	300	250	400
MFR 14	70		100	250	400	250	480*/400	250	200	250	300	250	400
MFR 8	50	Spacing a / s _{1,min} perpendicular to edge	50	250	200	250	200	250	200	250	200	250	200
MFR 10	50		50	250	200	250	200	–	–	–	–	–	–
MFR 10	70		50	250	200	250	200	250	100	250	150	250	200
MFR 14	70		100	250	200	250	240*/200	250	100	250	150	250	200
MFR 8	50	Min. edge distance C _{min}	60	100	100	100	100	50	–	90	–	150	–
MFR 10	50		50	100	100	100	100	–	–	–	–	–	–
MFR 10	70		60	100	100	100	100	50	50	75	75	100	100
MFR 14	70		100	100	100	120*/100	120*/100	50	50	75	75	100	100
MFR 8	50	Min. thickness of structural part h _{min}	100					240	240	240	240	240	240
MFR 10	50		100	depending on brick format	depending on brick format	–	–	–	–	–	–	–	–
MFR 10	70		110			100	100	100	100	100	100	100	100
MFR 14	70		120			100	100	100	100	100	100	100	100

* Value applies to HLz 12

Hollow block frame plug HBR



Advantages

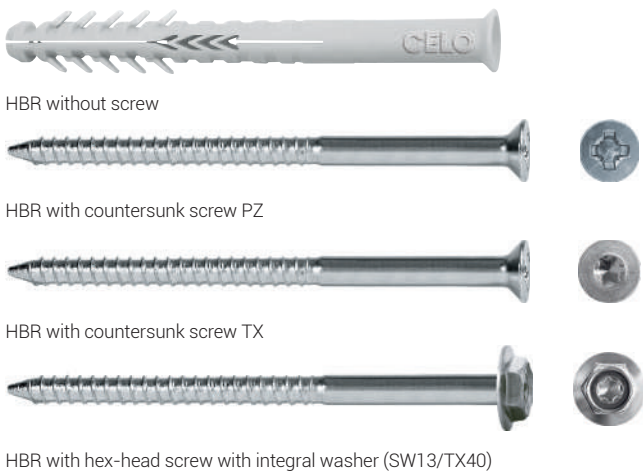

- ETA approved specialised frame plug for perforated building materials like hollow bricks and blocks
- Setting depth 90 mm: High pull out loads due to long expansion area and high expansion ability in perforated bricks
- The HBR is suitable for façade installations, fixing of doors and windows, wall cabinets and frames in general
- The HBR 10 is approved only in conjunction with the CELO safety screws

Suitable building materials

Very suitable

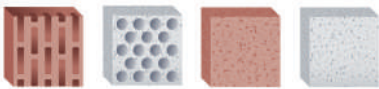

- Hollow brick
- Hollow sand-lime brick
- Solid sand-lime brick
- Lightweight hollow concrete blocks
- Lightweight solid concrete blocks
- Aerated concrete

Suitable



- Concrete

Approvals and certificates

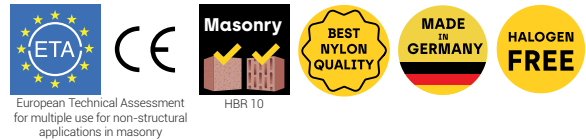

Mounting

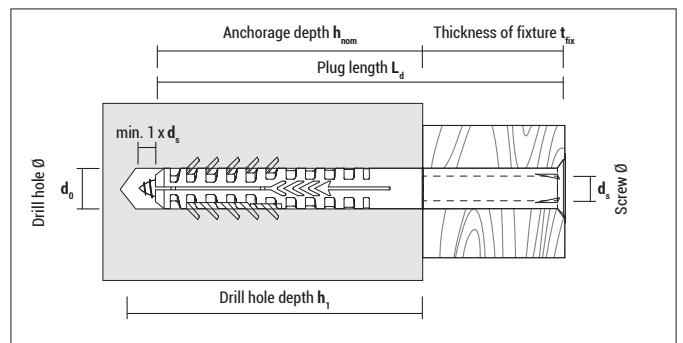
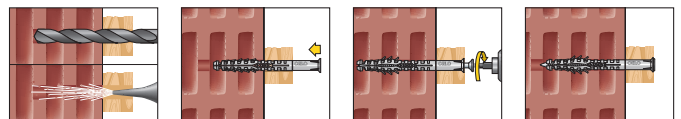



HBR without screw

Type	Art-No	d ₀ [mm]	h ₁ ≥ [mm]	h _{nom} ≥ [mm]	L _d [mm]	t _{fix} ≤ [mm]	d _s [mm]	€ / 100 pcs		
8x80*	9880HBR	8	80	65	80	15	5 - 6		50	900
10x100	910100HBR	10	100	90	100	10	6 - 7		100	800
10x115	910115HBR	10	100	90	115	25	6 - 7		100	800
10x135	910135HBR	10	100	90	135	45	6 - 7		50	400
10x160	910160HBR	10	100	90	160	70	6 - 7		50	400
10x200	910200HBR	10	100	90	200	110	6 - 7		50	400
10x240	910240HBR	10	100	90	240	150	6 - 7		50	400

* Not part of the assessment; HBR 10 approved only in conjunction with CELO safety screw



HBR SP, zinc plated with countersunk screw (HBR 8: PZ 3, HBR 10: PZ4)

Type	Art-No	d ₀ [mm]	h ₁ ≥ [mm]	h _{nom} ≥ [mm]	L _d [mm]	t _{fix} ≤ [mm]	d _s [mm]		€ / 100 pcs		
8x80 SP	9880HBRSZ	8	80	65	80	15	5,5	—		25	450
10x115 SSP*	910115HBRSZ	10	100	90	115	25	7	●		50	400

* discontinued article, delivery while stocks last



HBR 10 TX, zinc plated with countersunk screw (TX 40)

Type	Art-No	d ₀ [mm]	h ₁ ≥ [mm]	h _{nom} ≥ [mm]	L _d [mm]	t _{fix} ≤ [mm]	d _s [mm]		€ / 100 pcs		
10x100 TX	910100HBRST	10	100	90	100	10	7	●		50	400
10x115 TX	910115HBRST	10	100	90	115	25	7	●		50	400
10x135 TX	910135HBRST	10	100	90	135	45	7	●		50	400
10x160 TX	910160HBRST	10	100	90	160	70	7	●		50	400
10x200 TX	910200HBRST	10	100	90	200	110	7	●		25	200
10x240 TX	910240HBRST	10	100	90	240	150	7	●		25	200



HBR 10 SSK, zinc plated with hex-head screw with integral washer (SW13/TX40)

Type	Art-No	d ₀ [mm]	h ₁ ≥ [mm]	h _{nom} ≥ [mm]	L _d [mm]	t _{fix} ≤ [mm]	d _s [mm]		€ / 100 pcs		
10x100 SSK	910100HBRSB	10	100	90	100	10	7	●		50	400
10x115 SSK	910115HBRSB	10	100	90	115	25	7	●		50	400
10x135 SSK	910135HBRSB	10	100	90	135	45	7	●		50	400
10x160 SSK	910160HBRSB	10	100	90	160	70	7	●		50	400
10x200 SSK	910200HBRSB	10	100	90	200	110	7	●		25	200
10x240 SSK	910240HBRSB	10	100	90	240	150	7	●		25	—

Loads F_{per} and F_{rec}

Type	Solid sand-lime brick ≥ KS 12		Hollow brick ≥ HLz 12		Hollow sand-lime brick ≥ KSL 12		Hollow concrete blocks Hb1 2		Lightweight solid concrete blocks V2		Permissible bending moment for zinc plated screws M _{per} [Nm]
	F _{per} [kN]	F _{rec} [kN]	F _{per} [kN]	F _{rec} [kN]	F _{per} [kN]	F _{rec} [kN]	F _{per} [kN]	F _{rec} [kN]	F _{per} [kN]	F _{rec} [kN]	
HBR 8	—	1,30	—	0,40	—	0,50	—	0,37	—	0,37	4,5
HBR 10	0,86	—	0,34	—	0,21	—	0,11	—	—	0,25	13,0

F_{per}: Permissible load in all directions according to ETA assessment. Load figures include the resistances' partial safety factors as per ETA assessments and a partial safety factor on the action of v_f = 1,4.

F_{rec}: Recommended load in all directions incl. safety factor

Values apply to an average temperature range in the wall of max. + 24° C (temporarily + 40° C).

If the sustained average temperature is +50° C (temporarily +80° C) load capacities are reduced. In this case, refer to the assessment.

Spacing and edge distance

Type	Distances	Solid sand-lime brick KS		Hollow brick HLz		Hollow sand-lime brick KSL		Hollow concrete blocks Hb1		
		single plug [mm]	group of plugs [mm]	single plug [mm]	group of plugs [mm]	single plug [mm]	group of plugs [mm]	single plug [mm]	group of plugs [mm]	
HBR 10	Spacing parallel to edge	a or s ₂	250	400	250	320	250	360	250	200
HBR 10	Spacing perpendicular to edge	a or s ₁	250	200	250	160	250	180	250	100
HBR 10	Min. edge distance	c _{min}	100	—	80	—	80	—	50	—
HBR 10	Min. thickness of structural part	h _{min}	175	175	175	175	175	175	240	240

* Applies to the installation on the long side of the stone

Nail plug NP



Advantages



Countersunk plug NPC 5, NPC 6 and NP 8



Flat rim plug NP 5 and NP 6



Countersunk plug NP 6 and NP 8 with metric thread

- For the quick fixing of frames, slats, channels, foils, electrical clamps, etc.
- Also suitable for window and door frame installation
- An accurate tuning between plug and nailscrew results in optimal expansion and thus high pull out loads
- Integral barrier prevents premature expansion
- Protection of the nailscrew head during hammering-in by a raised ring
- All nailscrews with PZ recess, so screwing in and out is also possible

Suitable building materials

Very suitable



- Concrete
- Natural stone
- Solid brick
- Solid sand-lime brick
- Lightweight solid concrete blocks

Suitable



- Hollow brick HLz
- Hollow sand-lime brick KSL
- Lightweight hollow concrete blocks
- Aerated concrete

Approvals and certificates



Mounting

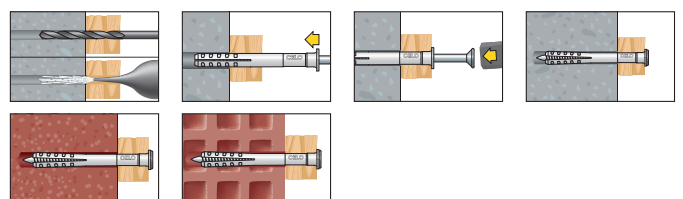

Nail plug NP

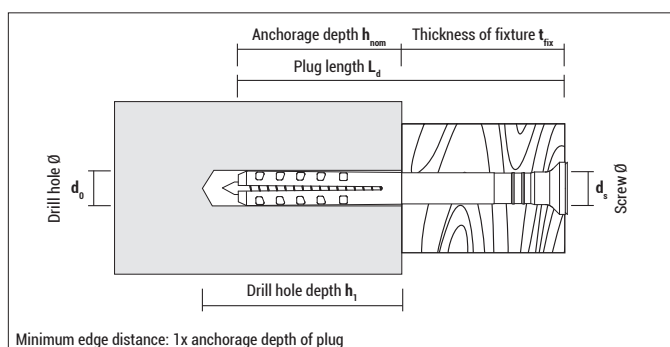

NPC and NP, zinc plated countersunk plug with countersunk screw pre-assembled

Type	Art-No	d ₀ [mm]	h ₁ ≥ [mm]	h _{nom} ≥ [mm]	L _d [mm]	t _{fix} ≤ [mm]	Drive	€/ 100 pcs	[pcs]	[pcs]
NPC 5x35	9535NPC	5	35	25	35	10	PZ 2		100	1.800
NPC 5x50	9550NPC	5	35	25	50	25	PZ 2		100	1.800
NPC 6x35	9635NPC	6	40	30	35	5	PZ 2		100	1.800
NPC 6x40	9640NPC	6	40	30	40	10	PZ 2		100	1.800
NPC 6x50	9650NPC	6	40	30	50	20	PZ 2		50	900
NPC 6x60	9660NPC	6	40	30	60	30	PZ 2		50	900
NPC 6x80	9680NPC	6	40	30	80	50	PZ 2		50	900
NP 8x60	9860NP	8	50	40	60	20	PZ 3		50	600
NP 8x60 ¹⁾	9860NP100	8	50	40	60	20	PZ 3		100	800
NP 8x80	9880NP	8	50	40	80	40	PZ 3		50	600
NP 8x80 ¹⁾	9880NP100	8	50	40	80	40	PZ 3		100	800
NP 8x100	98100NP	8	50	40	100	60	PZ 3		50	600
NP 8x100 ¹⁾	98100NP100	8	50	40	100	60	PZ 3		100	800
NP 8x120	98120NP	8	50	40	120	80	PZ 3		50	400
NP 8x120 ¹⁾	98120NP100	8	50	40	120	80	PZ 3		100	800
NP 8x135	98135NP	8	50	40	135	95	PZ 3		50	400

¹⁾Craftsman pack (box without viewing window)



NP, zinc plated flat rim plug with countersunk screw, pre-assembled

Type	Art-No	d ₀ [mm]	h ₁ ≥ [mm]	h _{nom} ≥ [mm]	L _d [mm]	t _{fix} ≤ [mm]	Drive	€/ 100 pcs	[pcs]	[pcs]
NP 5x25	9525NP	5	25	23	25	2	PZ 2		200	3.600
NP 5x35	9535NP	5	35	25	35	10	PZ 2		100	1.800
NP 5x50 *	9550NP	5	35	25	50	25	PZ 2		100	1.800
NP 6x35	9635NP	6	40	30	35	5	PZ 2		100	1.800
NP 6x40	9640NP	6	40	30	40	10	PZ 2		100	1.800
NP 6x40 ¹⁾	9640NP300	6	40	30	40	10	PZ 2		300	2.400
NP 6x50	9650NP	6	40	30	50	20	PZ 2		50	900
NP 6x60	9660NP	6	40	30	60	30	PZ 2		50	900
NP 6x60 ¹⁾	9660NP250	6	40	30	60	30	PZ 2		250	2.000
NP 6x70	9670NP	6	40	30	70	40	PZ 2		50	900
NP 6x80	9680NP	6	40	30	80	50	PZ 2		50	900
NP 6x80 ¹⁾	9680NP200	6	40	30	80	50	PZ 2		200	1.600

* discontinued article, delivery while stocks last

¹⁾Craftsman pack (box without viewing window)

Nail plug NP



A2
STAINLESS
STEEL

NP, stainless steel A2 flat rim plug with countersunk screw, pre-assembled

Type	Art-No	d ₀ [mm]	h ₁ ≥ [mm]	h _{nom} ≥ [mm]	L _d [mm]	t _{fix} ≤ [mm]	Drive	€ / 100 pcs	[pcs]	[pcs]
NP 5x35 A2	9X535NP	5	35	25	35	10	PZ 2		100	1.800
NP 5x50 A2	9X550NP	5	35	25	50	25	PZ 2		100	1.800
NP 6x40 A2	9X640NP	6	40	30	40	10	PZ 2		100	1.800
NP 6x60 A2	9X660NP	6	40	30	60	30	PZ 2		50	900
NP 6x80 A2	9X680NP	6	40	30	80	50	PZ 2		50	900



A2
STAINLESS
STEEL

NP, stainless steel A2 countersunk plug with countersunk screw, pre-assembled

Type	Art-No	d ₀ [mm]	h ₁ ≥ [mm]	h _{nom} ≥ [mm]	L _d [mm]	t _{fix} ≤ [mm]	Drive	€ / 100 pcs	[pcs]	[pcs]
NP 8x60 A2	9X860NP	8	50	40	60	20	PZ 3		50	600
NP 8x80 A2	9X880NP	8	50	40	80	40	PZ 3		50	600



NP, zinc plated countersunk plug, nail screw with metric thread, pre-assembled

Type	Art-No	d ₀ [mm]	h ₁ ≥ [mm]	h _{nom} ≥ [mm]	L _d [mm]	t _{fix} ≤ [mm]	Thread length [mm]	Drive	€ / 100 pcs	[pcs]	[pcs]
NP 6x40 M6	9640NPM6	6	40	30	40	10	5	PZ 2		100	1.800
NP 8x45 M8	9845NPM8	8	50	40	45	5	5	PZ 3		50	900



Blister NP, zinc plated pre-assembled, NP 5 and 6: flat rim plug, NP8: countersunk plug



Type	Art-No	d ₀ [mm]	h ₁ ≥ [mm]	h _{nom} ≥ [mm]	L _d [mm]	t _{fix} ≤ [mm]	Drive	€ / Blister	[pcs]	[Blister]
NP 5x35	5535NP20	5	35	25	35	10	PZ 2		20	10
NP 5x50	5550NP20	5	35	25	50	25	PZ 2		20	10
NP 6x40	5640NP15	6	40	30	40	10	PZ 2		15	10
NP 6x60	5660NP15	6	40	30	60	30	PZ 2		15	10
NP 6x80	5680NP10	6	40	30	80	50	PZ 2		10	10
NP 8x60	5860NP10	8	50	40	60	20	PZ 3		10	10
NP 8x80	5880NP10	8	50	40	80	40	PZ 3		10	10
NP 8x100	58100NP10	8	50	40	100	60	PZ 3		10	10
NP 8x120	58120NP5	8	50	40	120	80	PZ 3		5	10
NP 8x135	58135NP5	8	50	40	135	95	PZ 3		5	10

Loads F_{rec}

Type	Concrete	Solid sand-lime brick KS 12	Aerated concrete AAC2	Aerated concrete AAC4	Hollow brick HLz 12
	F _{rec} [kN]	F _{rec} [kN]	F _{rec} [kN]	F _{rec} [kN]	F _{rec} [kN]
NP 5	0,18	0,15	0,04	0,08	0,07
NP 6	0,19	0,16	0,05	0,09	0,08
NP 8	0,24	0,21	0,08	0,12	0,09

F_{rec}: Recommended loads incl. safety factor of -6÷7

Universal Spreading Nail USN



Advantages



- Innovative fastening of wall connection profiles, metal sheets, base protection profiles, cornice covers, motion detectors, small lamps, signs, etc. without thermal bridge
- Suitable in almost all common building materials with good pull-out values
- The elastic V-shaped spring elements ensure a high spreading force
- Spreading nail made out of glass-fibre reinforced nylon with EPDM sealing; ageing, weather and UV-resistant
- Stylish head, different colours and different lengths
- Electrical contact protection through the use of plastics
- Easy disassembly by knocking off or drilling out the head
- For insulated walls use insulation screw IPS or insulation screw plug IPSD

Suitable building materials

Very suitable



- Concrete
- Natural stone
- Solid brick
- Solid sand-lime brick
- Lightweight solid concrete blocks
- Aerated concrete (only AAC6)
- Hollow brick
- Hollow sand-lime brick
- Lightweight hollow concrete blocks

Mounting

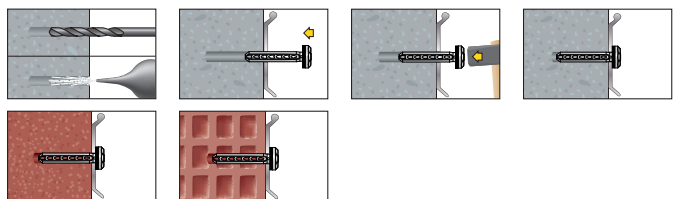

The USN can be removed in two ways:

1. **Knock off the head** using a chisel or a screwdriver.
2. **Drill out the head** with a drill bit that it falls apart (The USN has a small notch on the head which helps to guide a drill bit).

Approvals and certificates



Universal Spreading Nail USN

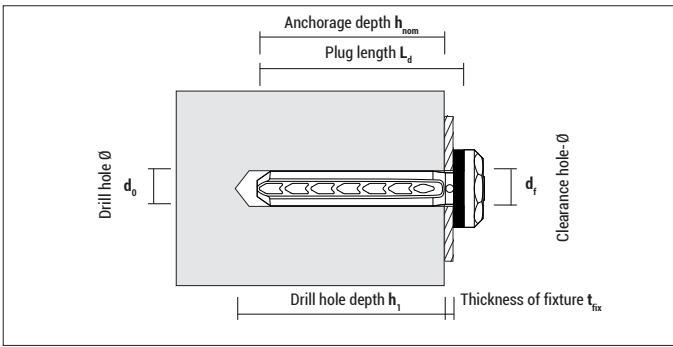

USN 6-40

USN 40 with EPDM sealing, head $\varnothing = 15,0$ mm

Type	Art-No	RAL-Code	d_0 [mm]	L_d [mm]	$h_1 \geq$ [mm]	$h_{nom} \geq$ [mm]	$t_{fix} \leq$ [mm]	d_f [mm]	€ / 100 pcs	[pcs]	[pcs]
USN 40 Signal white	9140USN	RAL 9003	6	40	40	35	5	8 - 10		100	1.800
USN 40 Telegrey	9GR40USN	RAL 7045	6	40	40	35	5	8 - 10		100	1.800
USN 40 Anthracite grey	9AN40USN	RAL 7016	6	40	40	35	5	8 - 10		100	1.800
USN 40 Traffic black	9440USN	RAL 9017	6	40	40	35	5	8 - 10		100	1.800
USN 40 Copper brown	9CO40USN	RAL 8004	6	40	40	35	5	8 - 10		100	1.800
USN 40 Sepia brown	9M40USN	RAL 8014	6	40	40	35	5	8 - 10		100	1.800
USN 40 Chocolate brown	9MO40USN	RAL 8017	6	40	40	35	5	8 - 10		100	1.800



USN 6-60

USN 60 with EPDM sealing, head $\varnothing = 15,0$ mm

Type	Art-No	RAL-Code	d_0 [mm]	L_d [mm]	$h_1 \geq$ [mm]	$h_{nom} \geq$ [mm]	$t_{fix} \leq$ [mm]	d_f [mm]	€ / 100 pcs	[pcs]	[pcs]
USN 60 Signal white	9160USN	RAL 9003	6	60	40	35	25	8 - 10		75	1.350
USN 60 Telegrey	9GR60USN	RAL 7045	6	60	40	35	25	8 - 10		75	1.350
USN 60 Anthracite grey	9AN60USN	RAL 7016	6	60	40	35	25	8 - 10		75	1.350
USN 60 Traffic black	9460USN	RAL 9017	6	60	40	35	25	8 - 10		75	1.350
USN 60 Copper brown	9CO60USN	RAL 8004	6	60	40	35	25	8 - 10		75	1.350
USN 60 Sepia brown	9M60USN	RAL 8014	6	60	40	35	25	8 - 10		75	1.350
USN 60 Chocolate brown	9MO60USN	RAL 8017	6	60	40	35	25	8 - 10		75	1.350

Loads and dimensions F_{rec}

Type	h_{nom} [mm]	Concrete		Hollow brick HLz 12 ¹⁾		Poroton T10 ¹⁾		Poroton T8 ¹⁾		Aerated concrete AAC6 ¹⁾²⁾	
		F_{rec} [kN]	F_{eff} [kN]	F_{rec} [kN]	F_{eff} [kN]	F_{rec} [kN]	F_{eff} [kN]	F_{rec} [kN]	F_{eff} [kN]	F_{rec} [kN]	F_{eff} [kN]
USN 40	35	0,13	0,93	0,08	0,55	0,03	0,20	0,08	0,60	0,04	0,32
USN 60	55	0,15	1,09	0,08	0,55	0,04	0,30	0,08	0,60	0,06	0,38

F_{rec} : Recommended load in all directions incl. safety factor of 7

F_{eff} : Effective pull out loads excl. safety factor

¹⁾ Drill without impact

²⁾ Recommendation: drill with $\varnothing 5$ drill bit

Nail plug NPZ



Advantages



- Metal nail plug for the fixing of rails, clamps, sheet metal, signs, etc.
- Nail made of hardened steel, zinc plated; plug made of zinc die casting
- Not removable due to flat nail head (theft protection)

Suitable building materials

Very suitable

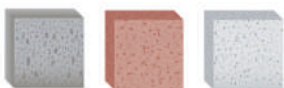

- Concrete
- Natural stone
- Solid brick
- Solid sand-lime brick
- Lightweight solid concrete blocks

Mounting

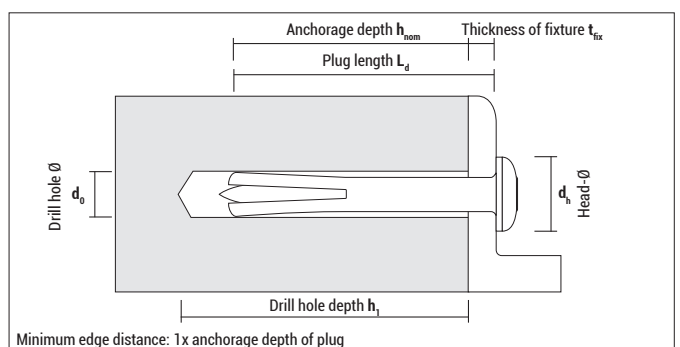
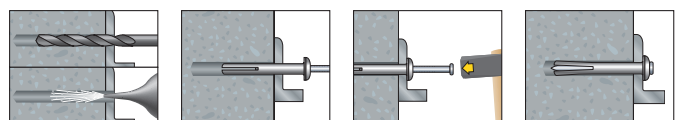

NPZ

Type	Art-No	d ₀ [mm]	h ₁ ≥ [mm]	h _{nom} ≥ [mm]	L _d [mm]	t _{fix} ≤ [mm]	d _n [mm]	€/100 pcs	[pcs]	[pcs]
NPZ 5x22 ¹⁾	9522NPZ	5	22	15	22	7	10,5		100	4.800
NPZ 5x40 ¹⁾	9540NPZ	5	25	20	40	20	10,5		100	3.000
NPZ 6x40	9640NPZ	6	25	20	40	20	12,6		100	2.000

¹⁾ discontinued article, delivery while stocks last

Loads F_{rec}

Concrete
F _{rec} [kN]
0,60
0,75
1,00

F_{rec}: Recommended loads incl. safety factor of 3

Quick-Fix nail BN



Advantages



BN



BDN

- Suitable for push-through installation of wooden slats, brackets, climbing lattices, hanging baskets for flowers or the like
- Quick and easy fixing: drill a hole and hammer it in - done
- The quick-fix nail is made of high-quality, galvanized spring steel and offers a secure grip in concrete and masonry
- The design of the product prevents interlocking in the box

Suitable building materials

Very suitable

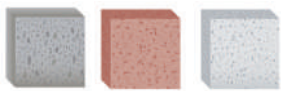

- Concrete
- Solid brick
- Solid sand-lime brick
- Lightweight solid concrete blocks
- Natural stone

Suitable to a limited extent

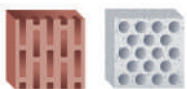

- Hollow brick
- Hollow sand-lime brick
- Lightweight hollow concrete blocks

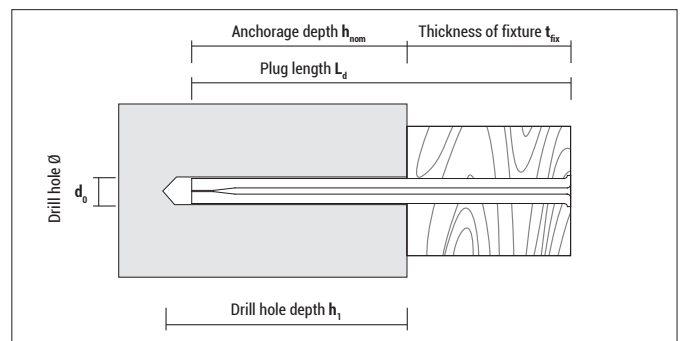
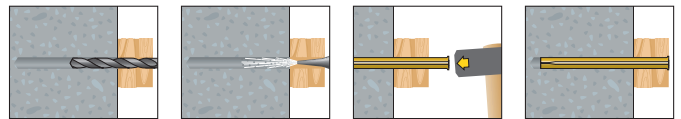

Mounting



Quick-fix nail BN





BN, zinc plated

Type	Art-No	d_0 [mm]	$h_1 \geq$ [mm]	$h_{nom} \geq$ [mm]	L_d [mm]	$t_{fix} \leq$ [mm]	€/100 pcs	 [pcs]	 [pcs]
BN 6x30	9B630BN	6	35	25	30	5		100	2.200
BN 6x60	9B660BN	6	40	30	60	30		100	1.200
BN 6x80	9B680BN	6	40	30	80	50		100	1.200
BN 8x70	9B870BN	8	50	40	70	30		50	1.100
BN 8x90	9B890BN	8	50	40	90	50		50	1.100
BN 8x110	9B8110BN	8	50	40	110	70		50	600
BN 8x130	9B8130BN	8	50	40	130	90		50	600
BN 8x150	9B8150BN	8	50	40	150	110		50	500



BDN, zinc plated Quick-Fix nail with punched hole [Perforation: 20 x 7,6 mm]

Type	Art-No	d_0 [mm]	$h_1 \geq$ [mm]	h_{nom} [mm]	€/100 pcs	 [pcs]	 [pcs]
BDN 8x32	9B832BDN	8	35	32		100	800

discontinued article, delivery while stocks last

Loads F_{rec} and F_{eff}

Type	Concrete	
	F_{rec} [kN]	F_{eff} [kN]
BN 6	0,8	2,5
BN 8, BDN	1,1	3,3

F_{rec} : Recommended loads incl. safety factor of 3

F_{eff} : Effective pull out loads excl. safety factor

Distance plate DP



Advantages



- Perfectly suited for equalising uneven surfaces when installing façade substructures, ETICS base profiles or similar installations
- Quick and easy installation: Only push the plate between the surface and the mounting part with your hand
- Universal usage; for all plugs and screws up to diameter 10 mm
- Common colours, so the thickness can be seen at a glance

Approvals and certificates

HALOGEN FREE

Mounting

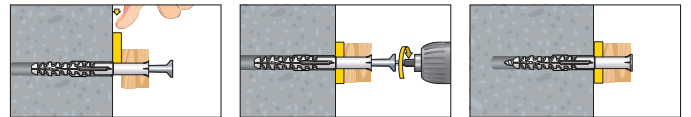

Distance plate DP 3 mm, red

Distance plate DP 5 mm, yellow

Distance plate DP 8 mm, blue

Distance plate DP 10 mm, black

Distance plate DP 15 mm, transparent

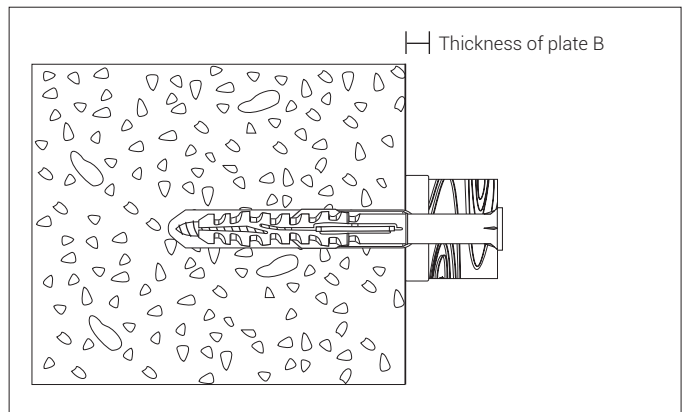

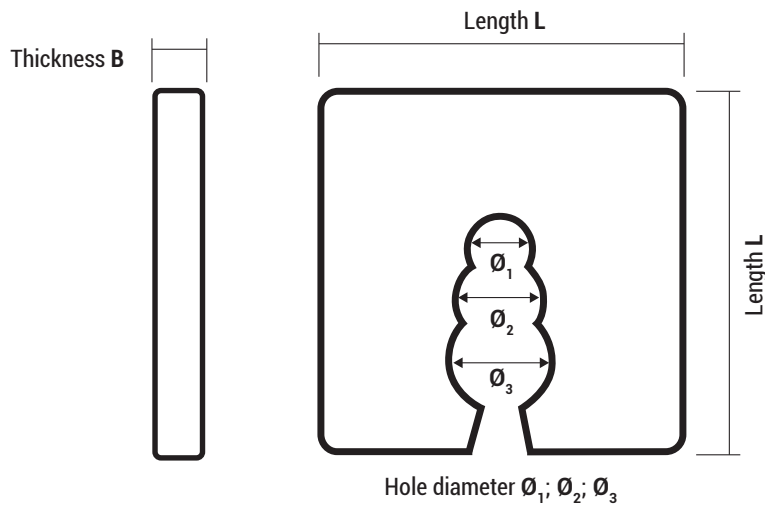

Type	Art-No	Colour	B [mm]	L [mm]	Ø ₁ [mm]	Ø ₂ [mm]	Ø ₃ [mm]	suitable for Type	see page	€ / 100 pcs	[pcs]	[pcs]
DP 3	3DP50	red	3	50	6	9	11	Nail plug NP	50		50	1.200
DP 5	5DP50	yellow	5	50	6	9	11	Quick-fix nail BN 6, 8	56		50	800
DP 8	8DP50	blue	8	50	6	9	11	Frame plug MFR 8, 10	43		50	600
DP 10	10DP50	black	10	50	6	9	11	Frame plugHBR 8, 10	48		50	500
DP 15	15DP50	transparent	15	50	6	9	11	Screws	205		50	500

Window Frame Fixings

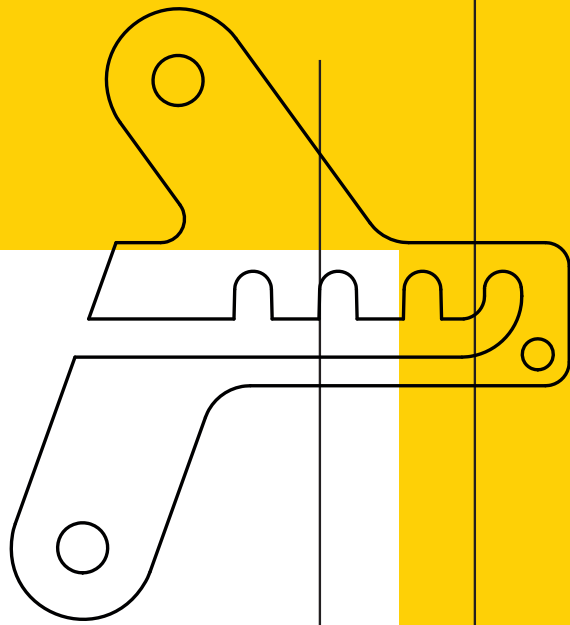

MR  61

FBS  63

FB  65

ProtectFIX  67

Metal frame plug

MR

Advantages



- Window and door frame installation free of constraint forces
- Stable metal design for distance installation
- Sendzimir zinc plated anchor sleeve for good protection against corrosion



Suitable building materials

Very suitable



- Concrete
- Natural stone
- Solid brick
- Solid sand-lime brick
- Lightweight solid concrete blocks

Suitable to a limited extent



- Hollow brick
- Hollow sand-lime brick
- Aerated concrete

Mounting

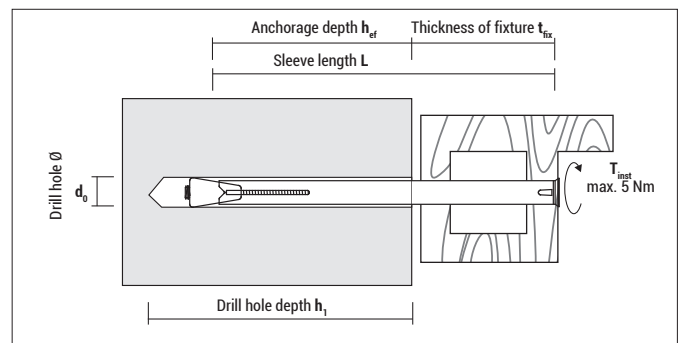
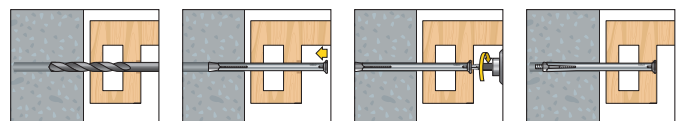

Metal frame plug MR

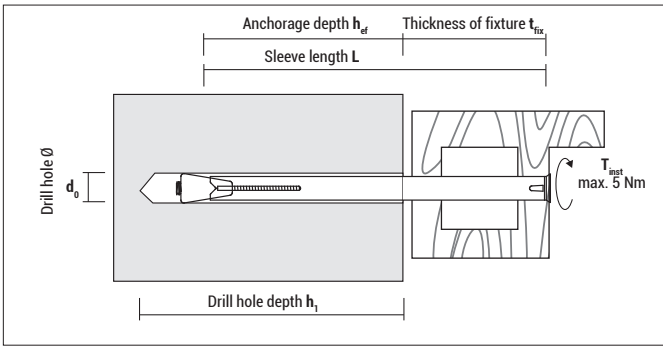

MR with countersunk screw (PZ 3)

Type	Art-No	d ₀ [mm]	h ₁ ≥ [mm]	h _{ef} ≥ [mm]	L ¹ [mm]	t _{fix} ≤ [mm]	€ / 100 pcs	[pcs]	[pcs]
MR 10x72	91072MR	10	50	30	72	42		100	600
MR 10x92	91092MR	10	50	30	92	62		100	400
MR 10x112	910112MR	10	50	30	112	82		100	400
MR 10x132	910132MR	10	50	30	132	102		100	400
MR 10x152	910152MR	10	50	30	152	122		100	400
MR 10x182	910182MR	10	50	30	182	152		100	400
MR 10x202	910202MR	10	50	30	202	172		100	400

¹ Sleeve length



Blister MR with countersunk screw (PZ 3)



Type	Art-No	d ₀ [mm]	h ₁ ≥ [mm]	h _{ef} ≥ [mm]	L ¹ [mm]	t _{fix} ≤ [mm]	€ / Blister	[pcs]	[Blister]
MR 10x92	51092MR6	10	50	30	92	62		6	10
MR 10x112	510112MR6	10	50	30	112	82		6	10
MR 10x132	510132MR6	10	50	30	132	102		6	10
MR 10x152	510152MR6	10	50	30	152	122		6	10

Incl. cover caps: 6 x white, 6 x brown

¹ Sleeve length

Loads F_{rec}

Type	Concrete F _{rec} [kN]	Solid sand-lime brick KS 12 F _{rec} [kN]	Solid brick Mz 12 F _{rec} [kN]	Lightweight solid concrete blocks V 12 F _{rec} [kN]	Hollow sand-lime brick KSL 6 F _{rec} [kN]
MR 10	1,35	1,25	1,25	0,45	0,5

F_{rec}: Recommended loads incl. safety factor of 4

Window frame screw

FBS & FBS-Z

Advantages



FBS with countersunk head



FBS-Z with socket head

- Special thread with reduced diameter at the screw tip reduces setting torque and therefore allows a longer battery life of your battery screwdriver
- Quick and easy installation
- Suitable for many different window types and a large number of base materials
- Both types with underhead milling ribs



Suitable building materials

Very suitable



- Concrete
- Natural stone
- Solid brick
- Aerated concrete
- Hollow brick
- Hollow sand-lime brick

Mounting

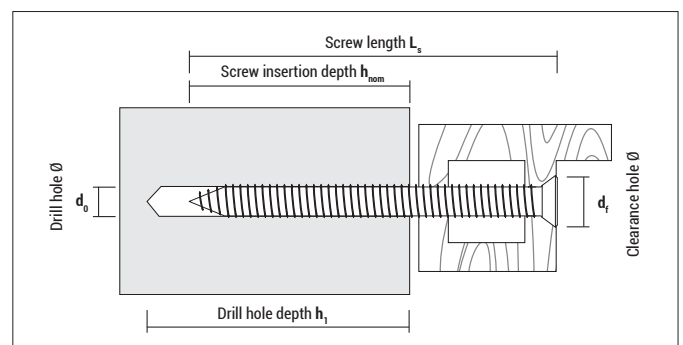
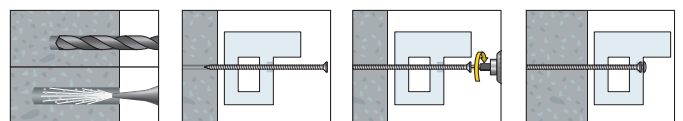

Window frame screw FBS & FBS-Z



FBS, zinc plated with countersunk head (ø 11 mm, TX 30), for metal and plastic window frames

Type Ø - L _s	Art-No	d ₀ [mm]	h ₁ ≥ [mm]	h _{nom} ≥ [mm]	d _f * [mm]	€/ 100 pcs	[pcs]	[pcs]
FBS 7,5 x 72	97572FBS	6	depends on building material, h _{nom} + 10 mm	depends on building material, see table „Loads“	6,2		100	600
FBS 7,5 x 92	97592FBS	6			6,2	100	600	
FBS 7,5 x 112	975112FBS	6			6,2	100	600	
FBS 7,5 x 132	975132FBS	6			6,2	100	600	
FBS 7,5 x 152	975152FBS	6			6,2	100	600	
FBS 7,5 x 182	975182FBS	6			6,2	100	600	
FBS 7,5 x 212	975212FBS	6			6,2	100	400	

* d_f: drill hole ø in window frame



FBS-Z, zinc plated with socket head (ø 8,3 mm, TX 30), for wooden window frames

Type Ø - L _s	Art-No	d ₀ [mm]	h ₁ ≥ [mm]	h _{nom} ≥ [mm]	d _f * [mm]	€/ 100 pcs	[pcs]	[pcs]
FBS-Z 7,5 x 72	97572FBSZ	6	depends on building material, h _{nom} + 10 mm	depends on building material, see table „Loads“	6,2		100	600
FBS-Z 7,5 x 92	97592FBSZ	6			6,2	100	600	
FBS-Z 7,5 x 112	975112FBSZ	6			6,2	100	600	
FBS-Z 7,5 x 132	975132FBSZ	6			6,2	100	600	
FBS-Z 7,5 x 152	975152FBSZ	6			6,2	100	600	
FBS-Z 7,5 x 182	975182FBSZ	6			6,2	100	600	
FBS-Z 7,5 x 212	975212FBSZ	6			6,2	100	400	

* d_f: drill hole ø in window frame



Blister FBS, zinc plated with countersunk head (ø 11 mm, TX 30), for metal and plastic window frames



Type Ø - L _s	Art-No	d ₀ [mm]	h ₁ ≥ [mm]	h _{nom} ≥ [mm]	d _f * [mm]	€/ Blister	[pcs]	[Blister]
FBS 7,5 x 112	575112FBS6	6	depends on building material, h _{nom} + 10 mm	depends on building material, see table „Loads“	6,2		6	10
FBS 7,5 x 132	575132FBS6	6			6,2	6	10	
FBS 7,5 x 152	575152FBS6	6			6,2	6	10	

Incl. cover caps: 6 x white, 6 x brown

* d_f: drill hole ø in window frame

Loads F_{rec} and installation parameters for FBS and FBS-Z

Type	Concrete	Solid brick ≥ Mz20	Solid sand-lime brick ≥ KS 12	Aerated concrete AAC6 ¹⁾	Hollow brick ¹⁾
Tension load F _{rec} [kN]	1,0	0,7	1,0	0,2	0,2
Shear load F _{rec} [kN]	0,5	-	-	-	-
Drill hole ø [mm]	6	6	6	6	6
Screw insertion depth h _{nom} [mm]	≥ 30	≥ 40	≥ 40	≥ 60	≥ 60 min. 2 brick walls
Min. drill hole depth h ₁ [mm]	≥ 40	≥ 50	≥ 50	≥ 70	-
Min. edge distance c _{min} [mm]	50	60	60	60	60

F_{rec} = Recommended loads in all directions incl. safety factors

¹⁾ Hole must be made with a rotary drill (hammer switched off)

Window fixing set

FB

Advantages



- The FB window fixing set - consisting of an extra-long plug and an extra-long distance screw - enables secure and tension-free installation of windows and doors
- The set is ideally suited for mounting windows and doors e.g. in thin-walled lightweight bricks with large chambers, in which normal window construction screws usually do not find enough hold
- The great length of the set ensures that the plug is always held in at least two webs of the brick, which guarantees high pull-out values and offers the user a high level of security
- No lateral spacers and support blocks required for window fastening
- Absorbs the thermal movements of the window, especially with large window elements - therefore no subsequent adjustment of the sash necessary
- Outstanding twist resistance of the plug thanks to pronounced anti-rotation wings and optimum expansion over the entire plug length
- Distance screw with reinforced shank diameter for increased bending moment
- 45 mm (Ø11 mm) retaining thread - for secure fixing of timber, aluminium and PVC-U windows as well as framed doors
- Setting depth marking for quick installation

Suitable building materials

Very suitable



- Aerated concrete
- Hollow brick
- Hollow sand-lime brick
- Lightweight hollow concrete blocks



Approvals and certificates



Mounting

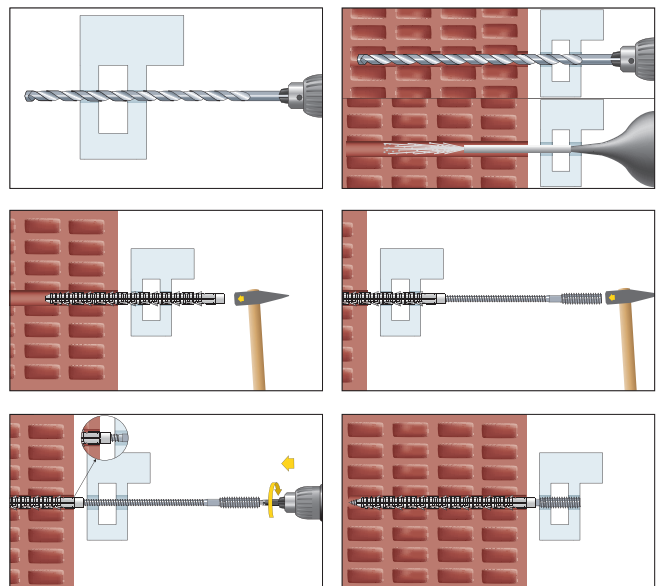

Window fixings set FB

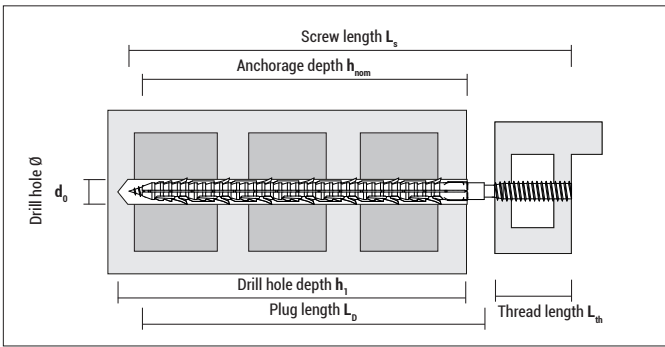

FB

Type	Art-No	d_0 [mm]	$h_1 \geq$ [mm]	h_{nom} [mm]	L_d [mm]	L_s [mm]	L_{th} [mm]	Screw drive [mm]	€/ 100 pcs	[pcs]	[pcs]
Set FB	910190280FB50	10	200	190	200	280	45	TX30		50	200

Spacing and edge distance

Type	min. edge distance [mm]	Frame distance e [mm]
Set FB	130	20

Window protection

ProtectFIX®

Advantages



- Tested window installation system for fall protection according to ETB guideline and tested according burglar resistance class RC2 (even for base materials with a compressive strength < 12, min. Poroton brick T8 or aerated concrete AAC2)
- First retrofittable system on the market
- Tested system with an edge distance of only 35 mm
- Only 3 mm material thickness ensures an easy installation with multifunctional sealing tapes
- Four different positioning options for more flexibility during the installation
- No pressure-resistant backfilling necessary
- To be used together with the frame plug MFR and the window frame screw FBS/FBSZ

Suitable building materials

Very suitable



- Concrete
- Natural stone
- Solid brick
- Solid sand-lime brick
- Aerated concrete
- Hollow brick
- Hollow sand-lime brick
- Wood



Approvals and certificates



Test report about burglary resistance class RC2



Test report according to DIN 18008-4 Cat.A



Mounting

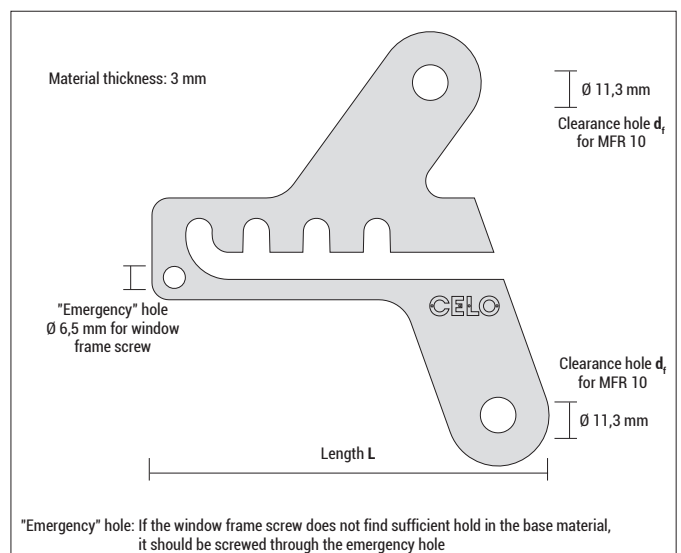

Window protection ProtectFIX®

Mounting in hollow brick

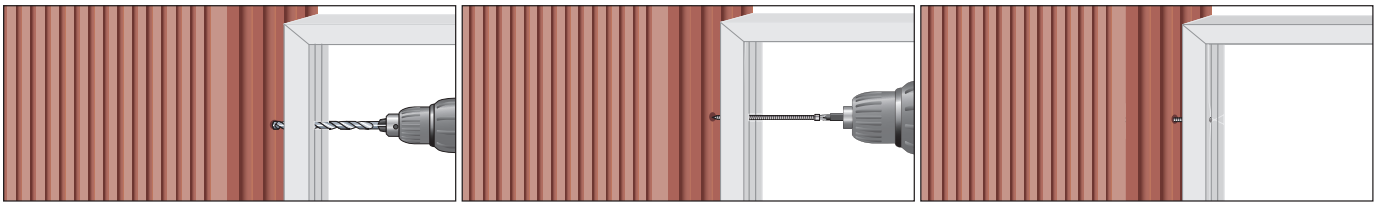

1. Place the window in the wall opening, adjust and drill holes. (for hollow brick and aerated concrete without impact).
2. Fix the window with window frame screws FBS-Z (distance between the window frame screws max. 400 mm, edge distance to the outer wall \geq 35 mm)
3. Common window installation is finished.

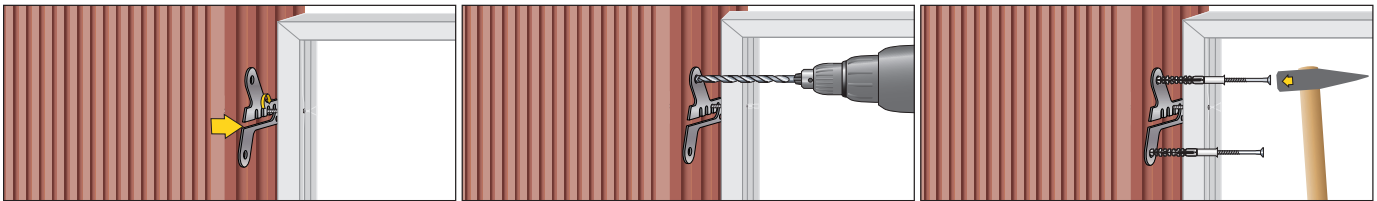

4. Hang ProtectFIX® on the window frame screw FBS-Z from the inside or outside. Position the screw in one of the four grooves and align the ProtectFIX horizontally.
5. Drill holes with \varnothing 10 mm.
6. Secure ProtectFIX® with two CELO multifunction frame plugs MFR SB 10-80 TX in the base material. To do this, hammer-in the MFR lightly into the drill hole up to the sleeve of the plug.

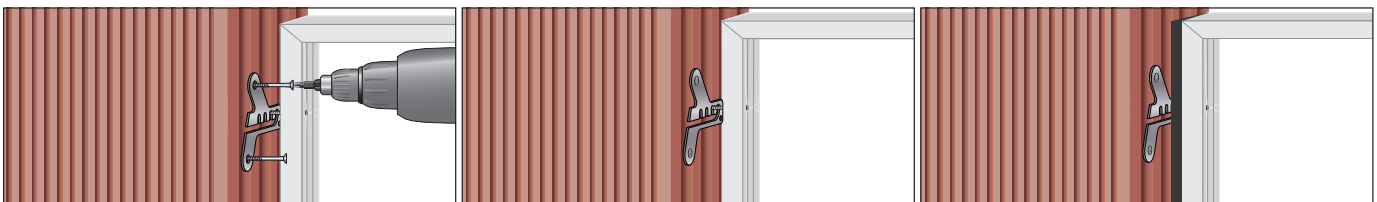

7. After hammer-in, screw in the MFR screws flush onto the ProtectFIX®.
 8. Installation with ProtectFIX® is finished and the fixing point is secured.
- Note:** ProtectFIX® can easily be used in combination with multifunctional sealing tapes, because the thickness of the ProtectFIX is only 3 mm

Example for installation



Window frame screw FBS-Z 7,5x152 or
Window frame screw FBS-Z 7,5x212



Multifunction frame plug MFR SB 10x80 TX



Window protection ProtectFIX®



ProtectFIX®, zinc plated

Type	Art-No	Box contains	Length L [mm]	Material thickness [mm]	€ / 1 pc	[pcs]	[pcs]
PFIX, bulk	G117PF	100x ProtectFIX® window support metal bracket 117	117	3		100	-



6x ProtectFIX®
Window support metal bracket



12x MFR
6x FBS-Z

Set ProtectFIX®, zinc plated

Type	Art-No	Set contains (packed in bag)	Length L [mm]	Material thickness [mm]	€ / Set	[pcs]	[pcs]
PFIX, Set, FBSZ152	117PF152FBSZ6	6x ProtectFIX® Window support metal bracket 117 12x Multifunction frame plug MFR SB 10x80 TX 6x Window frame screw FBS-Z 7,5x152	117	3		1	10
PFIX, Set, FBSZ212*	117PF212FBSZ6	6x ProtectFIX® Window support metal bracket 117 12x Multifunction frame plug MFR SB 10x80 TX 6x Window frame screw FBS-Z 7,5x212	117	3		1	10

1. Set with FBS-Z 7,5x152: for base materials with a compressive strength ≥ 12 , e.g. sand-lime brick, perforated bricks according DIN 1053-1 and concrete with a minimum strength class C10/15.

2. Set with FBS-Z 7,5x212: for base materials with a compressive strength < 12 , min. perforated brick Poroton T8, aerated concrete AAC2.

* The window frame screw FBS-Z must penetrate min. 2 brick walls.

Cavity Fixings

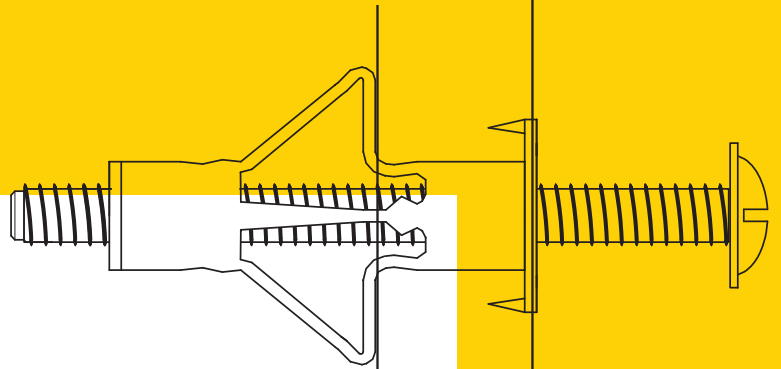

BT plus



71

FK



73

HRM



75

HR



77

GKD



79

GKDZ

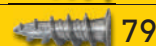

79

Cavity plug universal BT plus



Advantages



- Universal: useable for board thicknesses from 10 to 70 mm
- Very good load values
- Quick and easy handling
- No special installation tool required

Approvals and certificates



Suitable building materials

Very suitable



- Plasterboard/
Fibreboard
- Chipboard

Suitable to a limited extent

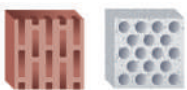

- Hollow bricks with
large chambers
- Hollow concrete
slab ceilings

Mounting

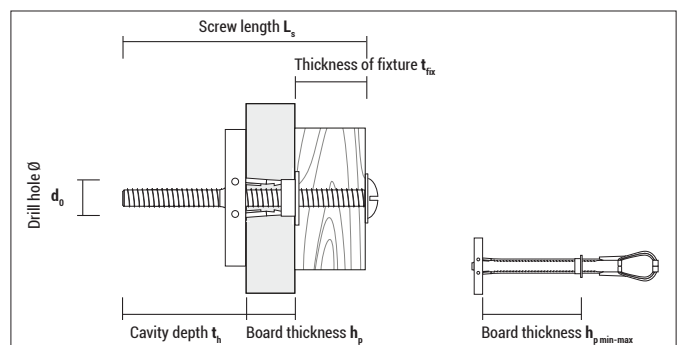
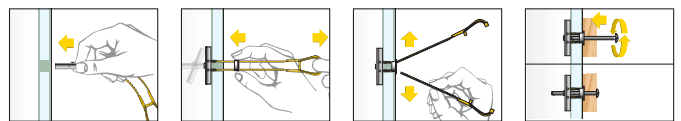

Minimum space t_h behind board: 51 mm

Cavity plug universal BT plus



BT plus without screw

Type	Art-No	d_0 [mm]	h_p min-max [mm]	Thread [mm]	€ / 100 pcs	[pcs]	[pcs]
BT plus M4	9Y4BTP	13	10 - 70	M4		40	320
BT plus M5	9Y5BTP	13	10 - 70	M5		30	240
BT plus M6	9Y6BTP	13	10 - 70	M6		30	240
BT plus M8	9Y8BTP	18	10 - 70	M8		20	160



BT plus with screw

Type	Art-No	d_0 [mm]	$h_p + t_{fix}$ [mm]	Thread [mm]	L_s [mm]	Recess	€ / 100 pcs	[pcs]	[pcs]
BT plus M4 LO	9Y4BTPL0	13	10 - 40	M 4	50	PZ2 / slot		40	320
BT plus M5 LO	9Y5BTPL0	13	10 - 52	M 5	62	PZ2 / slot		30	240
BT plus M6 LO	9Y6BTPL0	13	10 - 52	M 6	62	PZ2 / slot		30	240
BT plus M8 K	9Y8BTPK	18	10 - 48	M 8	60	SW13 / hex		20	160



Blister BT plus with screw



Type	Art-No	d_0 [mm]	$h_p + t_{fix}$ [mm]	Thread	L_s [mm]	Recess	€ / Blister	[pcs]	[Blister]
BT M4 LO	54BTLO4	13	10 - 40	M4	50	PZ2 / slot		4	10
BT M5 LO	55BTLO4	13	10 - 52	M5	62	PZ2 / slot		4	10
BT M6 LO	56BTLO4	13	10 - 52	M6	62	PZ2 / slot		4	10
BT M8 K	58BTK2	18	10 - 48	M8	60	SW13 / hex		2	10

Loads F_{rec}

Type	d_0 [mm]	Tension load N_{rec} in plasterboard				Shear load Q_{rec} in plasterboard			
		$h_p = 9,5$ mm [kN]	$h_p = 12,5$ mm [kN]	$h_p = 2 \times 9,5$ mm [kN]	$h_p = 2 \times 12,5$ mm [kN]	$h_p = 9,5$ mm [kN]	$h_p = 12,5$ mm [kN]	$h_p = 2 \times 9,5$ mm [kN]	$h_p = 2 \times 12,5$ mm [kN]
BT plus M4	13	0,07	0,15	0,15	0,30	0,20	0,20	0,25	0,30
BT plus M5	13	0,20	0,25	0,40	0,50	0,30	0,30	0,50	0,50
BT plus M6	13	0,20	0,25	0,40	0,50	0,30	0,30	0,50	0,50
BT plus M8	19	0,20	0,25	0,40	0,50	0,30	0,40	0,50	0,50

F_{rec} : Recommended loads incl. safety factor of min. 3

Spring toggle FK



Advantages



FK-S with washer and hexagon nut

FK-HS with round hook, washer and hexagon nut

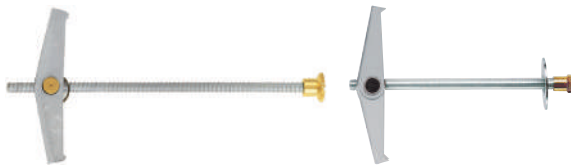

FK-R with knurled nut yellow galvanized

FK-UR with knurled nut and washer, yellow galvanized

- Suitable for fixings in cavity ceilings or walls, and boards like gypsum boards or chipboards

Suitable building materials

Very suitable



- Cavity ceilings
- Cavity walls
- Plasterboard/
Fibreboard
- Chipboard

Mounting

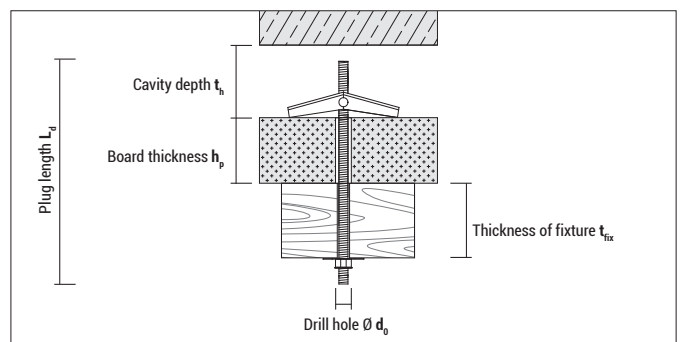
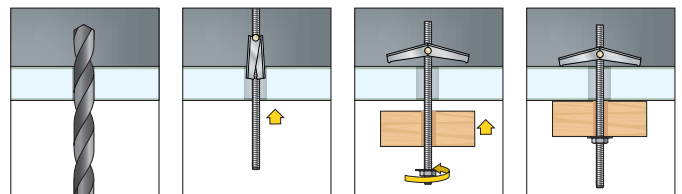

Spring toggle FK



FK-S with washer and hexagon nut

Type	Art-No	d ₀ [mm]	h _p + t _{fix} ≤ [mm]	Thread	L _d [mm]	t _n ≥ [mm]	€ / 100 pcs	[pcs]	[pcs]
3x85 S *	9390FKS	11	65	M3	85	28		25	-
4x90 S	9495FKS	14	65	M4	90	35		25	-

* discontinued article, delivery while stocks last



FK-HS with round hook, washer and hexagon nut

Type	Art-No	d ₀ [mm]	h _p + t _{fix} ≤ [mm]	Thread	L _d [mm]	t _n ≥ [mm]	€ / 100 pcs	[pcs]	[pcs]
3x100 HS *	9385FKHS	11	40	M3	100	28		25	-
4x95 HS	94100FKHS	14	30	M4	95	35		25	-

* discontinued article, delivery while stocks last



FK-R / FK-UR with knurled nut, yellow galvanized

Type	Art-No	d ₀ [mm]	h _p + t _{fix} ≤ [mm]	Thread	L _d [mm]	t _n ≥ [mm]	€ / 100 pcs	[pcs]	[pcs]
3x85 R *	9390FKR	11	65	M3	85	28		25	-
4x90 R	9495FKR	14	65	M4	90	35		25	-
3x85 UR *	9385FKUR	11	65	M3	85	28		25	-
4x90 UR	9490FKUR	14	65	M4	90	35		25	-

* discontinued article, delivery while stocks last



Blister FK-S with washer and hexagon nut
Blister FK-HS with round hook, washer and hexagon nut

Type	Art-No	d ₀ [mm]	h _p + t _{fix} ≤ [mm]	Thread	L _d [mm]	t _n ≥ [mm]	€ / Blister	[pcs]	[Blister]
FK-S 3x85 *	9390FKS	11	65	M3	85	28		2	10
FK-S 4 x 90	5495FKS2	14	65	M4	90	35		2	10
FK-HS 3x100 *	9385FKHS	11	40	M3	100	28		2	10
FK-HS 4 x 95	54100FKHS2	14	30	M4	95	35		2	10

* discontinued article, delivery while stocks last

Loads F_{rec} FK-S, FK-R, FK-UR

Type	Plasterboard h _p = 12,5 mm F _{rec} [kN]	Chipboard h _p = 13 mm F _{rec} [kN]	Fibre cement boards h _p = 10 mm F _{rec} [kN]
M3: FK-S, FK-R, FK-UR	0,15	0,25	0,25
M4: FK-S, FK-R, FK-UR	0,15	0,36	0,45

F_{rec}: Recommended loads incl. safety factor of 4

Loads F_{rec} FK-HS with round hook

Type	Plasterboard h _p = 12,5 mm F _{rec} [kN]	Chipboard h _p = 13 mm F _{rec} [kN]	Fibre cement boards h _p = 10 mm F _{rec} [kN]
M3: FK-HS	0,06*	0,06*	0,06*
M4: FK-HS	0,15*	0,15*	0,15*

F_{rec}: Recommended loads incl. safety factor of 4

* Bending of the hook is decisive.

Cavity fixing

HRM



Advantages

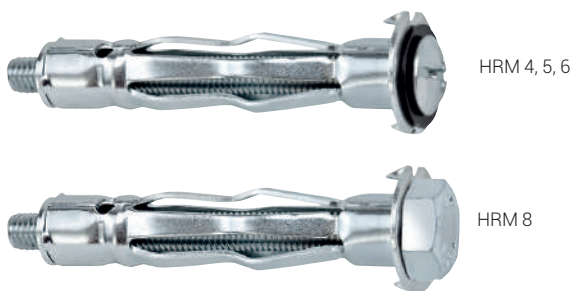

- Suitable for fixings on boards like gypsum boards or chipboards, but also in hollow ceilings for example
- After successful installation, the anchor expands over a large area, resulting in high load values
- Mounting with installation pliers MZA 100, cordless screwdriver and screwdriver possible; the installation pliers is recommended for a quick and controlled installation
- Not flammable according to DIN EN 13501-1, class A1

Suitable building materials

Very suitable



- Cavity ceilings
- Cavity walls
- Plasterboard/
Fibreboard
- Chipboard

Suitable to a limited extent



- Hollow bricks with large chambers

Mounting

Mounting with installation plier (recommended)

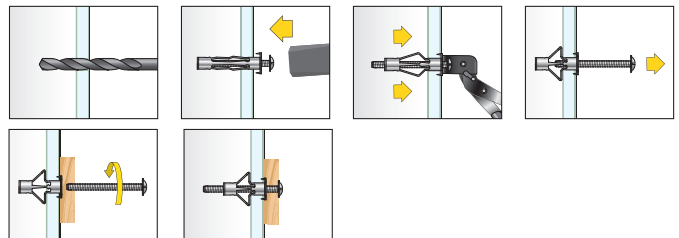

Mounting without installation plier

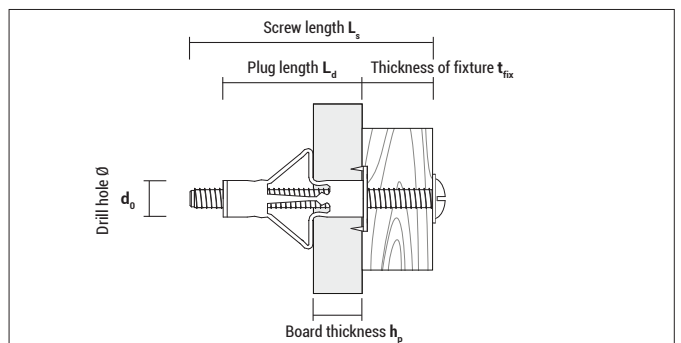
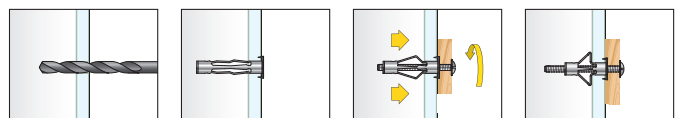

Installation plier MZA 100 for HRM



Type	Art-No	€ / pcs	[pcs]	[pcs]
MZA 100	9MZA00		1	-

Cavity plug metal HRM



HRM

Type	Art-No	d ₀ [mm]	h _p min-max [mm]	Thread	L _s [mm]	L _d [mm]	t _{fix} ¹⁾ [mm]	€ / 100 pcs	[pcs]	[pcs]	
small pack (with viewing window)	HRM 4x20	9420HRM50	8	3 - 18	M4	52	46	43 - 28		50	1.350
	HRM 4x24	9424HRM50	8	18 - 24	M4	58	52	34 - 28		50	1.350
	HRM 4x38	9438HRM50	8	32 - 38	M4	72	66	34 - 28		50	1.350
	HRM 5x16	9516HRM50	11	3 - 16	M5	58	52	49 - 36		50	1.350
	HRM 5x32	9532HRM25	11	14 - 32	M5	71	65	51 - 33		25	675
	HRM 5x45	9545HRM25	11	32 - 45	M5	88	80	48 - 35		25	675
	HRM 6x16	9616HRM25	13	3 - 16	M6	58	52	49 - 36		25	675
	HRM 6x32	9632HRM25	13	14 - 32	M6	71	65	51 - 33		25	675
	HRM 6x45	9645HRM25	13	32 - 45	M6	88	80	48 - 35		25	675
	HRM 8x16*	9816HRM25	13	3 - 16	M8	61	53	50 - 37		25	675
HRM 8x32*	9832HRM20	13	16 - 32	M8	73	66	50 - 34		20	360	
craftsman pack	HRM 4x20	9420HRM	8	3 - 18	M4	52	46	43 - 28		100	1.000
	HRM 4x24	9424HRM	8	18 - 24	M4	58	52	34 - 28		100	1.000
	HRM 4x38	9438HRM	8	32 - 38	M4	72	66	34 - 28		100	1.000
	HRM 5x16	9516HRM	11	3 - 16	M5	58	52	49 - 36		100	500
	HRM 5x32	9532HRM	11	14 - 32	M5	71	65	51 - 33		100	500
	HRM 5x45	9545HRM	11	32 - 45	M5	88	80	48 - 35		100	900
	HRM 6x16	9616HRM	13	3 - 16	M6	58	52	49 - 36		100	500
	HRM 6x32	9632HRM	13	14 - 32	M6	71	65	51 - 33		100	900
	HRM 6x45	9645HRM	13	32 - 45	M6	88	80	48 - 35		100	600
	HRM 8x16*	9816HRM	13	3 - 16	M8	61	53	50 - 37		100	300
HRM 8x32*	9832HRM	13	16 - 32	M8	73	66	50 - 34		100	300	

* Hex-head screw, SW 13

¹⁾ Please note: Thickness of fixture t_{fix} depends on the board thickness h_p



Blister HRM



Type	Art-No	d ₀ [mm]	h _p min-max [mm]	Thread	L _s [mm]	L _d [mm]	Type of screw	€ / Blister	[pcs]	[Blister]
4x20	5420HRM5	8	3 - 18	M4	52	46			5	10
4x24	5424HRM5	8	18 - 24	M4	58	52			5	10
5x16	5516HRM5	11	3 - 16	M5	58	52			5	10
5x16 RH	5516HRMRH4	11	3 - 16	M5	58	52			4	10
5x16 WH	5516HRMWH4	11	3 - 16	M5	58	52			4	10
5x32	5532HRM5	11	14 - 32	M5	71	65			5	10
5x32 RH	5532HRMRH4	11	14 - 32	M5	71	65			4	10
5x32 WH	5532HRMWH4	11	14 - 32	M5	71	65			4	10
6x16	5616HRM5	13	3 - 16	M6	58	52			5	10
6x32	5632HRM5	13	14 - 32	M6	71	65			5	10

Loads F_{rec}

Type	Plywood		Plasterboard			
	6 mm F _{rec} [kN]	Chipboard 16 mm F _{rec} [kN]	h _p = 9,5 mm F _{rec} [kN]	h _p = 12,5 mm F _{rec} [kN]	h _p = 2 x 12,5 mm F _{rec} [kN]	h _p = 3 x 12,5 mm F _{rec} [kN]
HRM 4x20	0,15	0,25	0,15	0,15	-	-
HRM 4x24	-	-	-	-	0,15	-
HRM 4x38	-	-	-	-	-	0,25
HRM 5x16	0,20	0,25	0,20	0,20	-	-
HRM 5x32	-	-	-	-	0,35	-
HRM 5x45	-	-	-	-	-	0,35
HRM 6x16	0,25	0,30	0,25	0,25	-	-
HRM 6x32	-	-	-	-	0,35	-
HRM 6x45	-	-	-	-	-	0,40
HRM 8x16	0,30	0,40	0,25	0,25	-	-
HRM 8x32	-	-	-	-	0,40	-

F_{rec}: Recommended loads incl. safety factor of 3

Cavity fixing

HR

Advantages



- Suitable for fixings on boards like gypsum boards and chipboards
- Low-cost fixing system for light duty applications
- Installation with wood screws or chipboard screws



Approvals and certificates



Suitable building materials

Very suitable



- Plasterboard/
Fibreboard

- Chipboard

Mounting

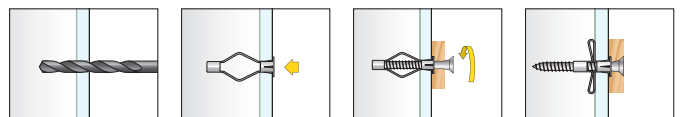

Cavity fixing HR

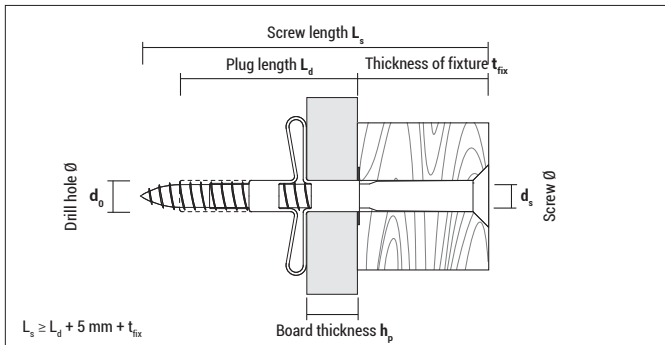

HR

Type	Art-No	d_0 [mm]	h_p min-max [mm]	d_s [mm]	L_d [mm]	€ / 100 pcs	[pcs]	[pcs]
HR 6x30	9630HR	6	3 - 14	3,5	30		100	4.800
HR 8x40	9840HR	8	10 - 16	4,0	40		50	2.400



Blister HR



Type	Art-No	d_0 [mm]	h_p min-max [mm]	$d_s \times L_s$ [mm]	L_d [mm]	€ / Blister	[pcs]	[Blister]
HR 6x30 SPS	56HRSZ20	6	3 - 14	3,5 x 50	30		20	10
HR 8x40 SPS	58HRSZ20	8	10 - 16	4,0 x 60	40		20	10

Loads F_{rec}

Type	Plywood	Chipboard	Plasterboard	
	6 mm F_{rec} [kN]	16 mm F_{rec} [kN]	$h_p = 9,5$ mm F_{rec} [kN]	$h_p = 12,5$ mm F_{rec} [kN]
HR 6x30	0,10	-	0,08	0,08
HR 8x40	-	0,15	-	0,10

F_{rec} : Recommended loads incl. safety factor of 3

Plasterboard plug GKD & GKDZ

Advantages



GKD made of nylon (glass-fibre reinforced)



GKDZ made of zinc die casting

- Suitable for fixings in gypsum boards
- Quick installation (no predrilling) for light loads
- Usable with chipboard screws or wood screws; GKDZ also with metric screws M4
- If the screw is longer than the plug (GKD or GKDZ), it simply screws through the tip of the plug

Suitable building materials

Very suitable



- Plasterboard/
Fibreboard

Suitable to a limited extent

- Gypsum fibreboards

Approvals and certificates



Mounting GKD

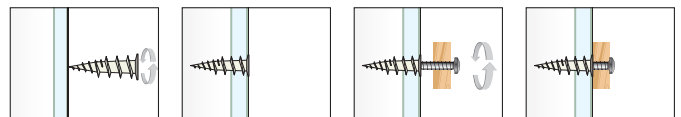

Mounting GKDZ

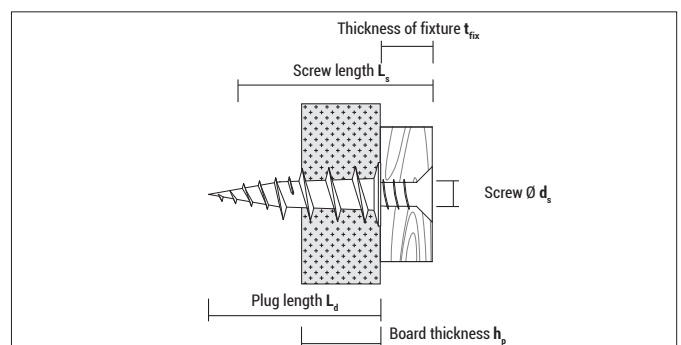
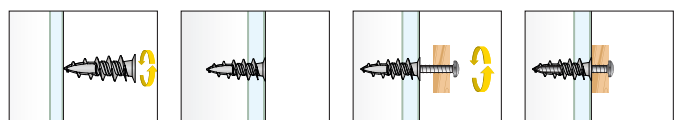

CELO



GKD without screw, plug recess: PH 2

Type	Art-No	L_d [mm]	$h_{p,max}$ [mm]	$d_{s,min-max}$ [mm]	$L_s \geq$ [mm]	€ / 100 pcs	[pcs]	[pcs]
GKD	9GKD	35	9-12,5	3,0 - 4,5	$22 + t_{fix}$		50	2.400



GKD with screw 4,0 x 40, plug recess: PH 2

Type	Art-No	L_d [mm]	$h_{p,max}$ [mm]	$d_s \times L_s$ [mm]	$t_{fix} \leq$ [mm]	€ / 100 pcs	[pcs]	[pcs]
GKD PZ	9GKDPZ	35	9-12,5	4,0 x 40	18		50	2.400



GKDZ without screw, plug recess: PH 2 / PZ 2

Type	Art-No	L_d [mm]	$h_{p,max}$ [mm]	d_s [mm]	$L_s \geq$ [mm]	€ / 100 pcs	[pcs]	[pcs]
GKDZ 37*	937GKDZ	37	9	4,5	$19 + t_{fix}$		100	2.700
GKDZ 37	937GKDZ50	37	9	4,5	$19 + t_{fix}$		50	2.400

* Craftsman pack (box without viewing window)



GKDZ with screw 4,5 x 35, plug recess: PH 2 / PZ 2

Type	Art-No	L_d [mm]	$h_{p,max}$ [mm]	$d_s \times L_s$ [mm]	$t_{fix} \leq$ [mm]	€ / 100 pcs	[pcs]	[pcs]
GKDZ 37 PZ	937GKDZPZ50	37	9	4,5 x 35	16		50	2.400



Blister GKD without screw

Type	Art-No	L_d [mm]	$h_{p,max}$ [mm]	$d_{s,min-max}$ [mm]	L_s [mm]	€ / Blister	[pcs]	[Blister]
GKD	5GKD10	35	9-12,5	3 - 4,5	$22 + t_{fix}$		10	10



Blister GKD with screw

Type	Art-No	L_d [mm]	$h_{p,max}$ [mm]	$d_s \times L_s$ [mm]	Type of screw	€ / Blister	[pcs]	[Blister]
GKD PZ	5GKDPZ6	35	9-12,5	4,0 x 40			6	10



Blister GKDZ without screw

Type	Art-No	L_d [mm]	$h_{p,max}$ [mm]	d_s [mm]	L_s [mm]	€ / Blister	[pcs]	[Blister]
GKDZ 37	537GKDZ10	37	9	4,5	$19 + t_{fix}$		10	10



Blister GKDZ with screw

Type	Art-No	L_d [mm]	$h_{p,max}$ [mm]	$d_s \times L_s$ [mm]	Type of screw	€ / Blister	[pcs]	[Blister]
GKDZ 37 PZ	537GKDZS26	37	9	4,5 x 35			6	10

Loads F_{rec}

Type	Plasterboard $h_p = 12,5$ mm F_{rec} [kN]	Plasterboard $h_p \geq 2 \times 12,5$ mm F_{rec} [kN]
GKD	0,07	-
GKDZ	0,08	0,16

F_{rec} : Recommended loads incl. safety factor of 4

Fixing of insulation boards

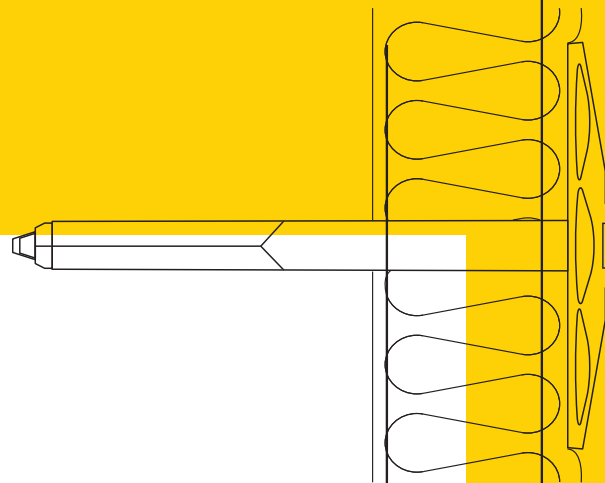

DSH  82

DSH-M  82

DST  84

DSH-T  84

IPD  85

Insulation support

DSH & DSH-M

Advantages

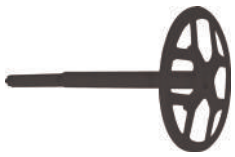

DSH made of impact resistant plastics



DSH-M made of metal

- DSH: Stable shape prevents bending when hammered in
- DSH: Suitable for fastening soft insulation materials onto concrete and solid masonry
- DSH-M: Not flammable according to DIN EN 13501-1, class A1
- DSH-M: Suitable for fixing insulating material to concrete and masonry

Suitable building materials

Very suitable



- Concrete
- Natural stone
- Solid brick
- Solid sand-lime brick

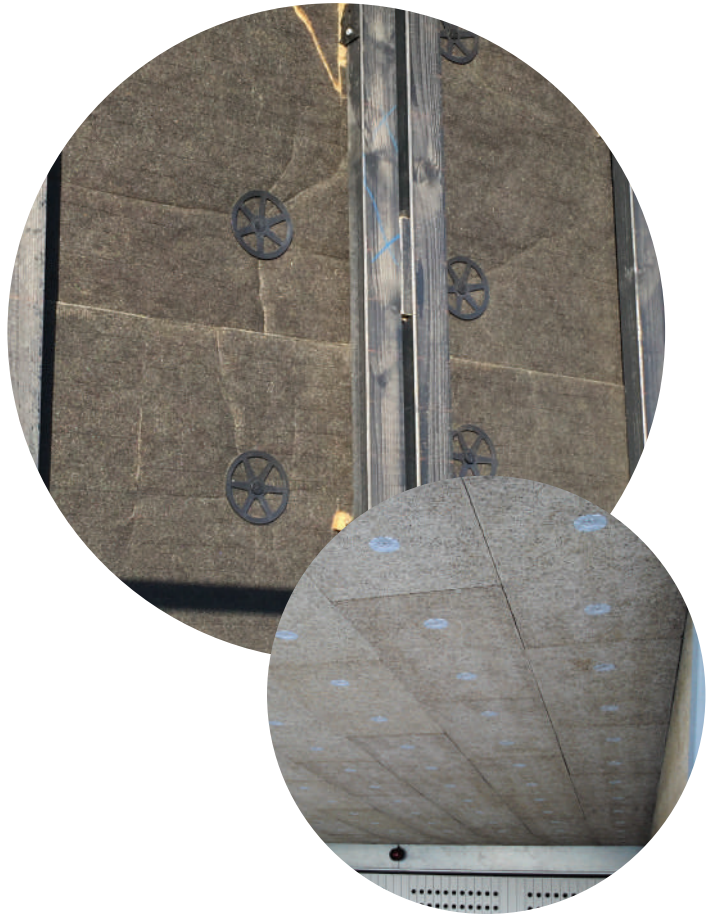

Approvals and certificates

HALOGEN
FREE

Mounting

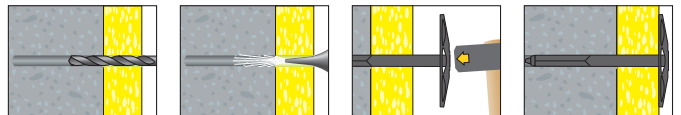

Insulation support DSH & DSH-M

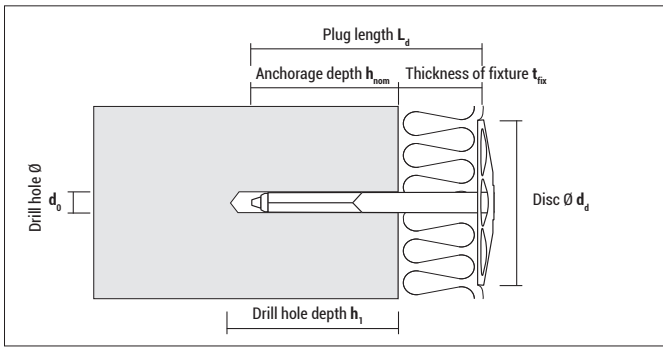

DSH

Type	Art-No	d_0 [mm]	$h_1 \geq$ [mm]	$h_{nom} \geq$ [mm]	L_d [mm]	d_d [mm]	t_{fix} [mm]	€/100 pcs	[pcs]	[pcs]
DSH 8x20	94860DSH	8	40	30	60	82	20 - 30		100	–
DSH 8x40	94880DSH	8	40	30	80	82	40 - 50		100	–
DSH 8x60	948100DSH	8	40	30	100	82	60 - 70		100	–
DSH 8x80	948120DSH	8	40	30	120	82	80 - 90		100	–
DSH 8x100	948140DSH	8	40	30	140	82	100 - 110		100	–



DSH-M

Type	Art-No	d_0 [mm]	$h_1 \geq$ [mm]	$h_{nom} \geq$ [mm]	L_d [mm]	d_d [mm]	$t_{fix} \leq$ [mm]	€/100 pcs	[pcs]	[pcs]
DSH-M 10	9860DSHM	8	60	50	60	35	10		250	–
DSH-M 30	9880DSHM	8	60	50	80	35	30		250	–
DSH-M 60	98110DSHM	8	60	50	110	35	60		250	–
DSH-M 90	98140DSHM	8	60	50	140	35	90		250	–
DSH-M 120	98170DSHM	8	60	50	170	35	120		250	–
DSH-M 150	98200DSHM	8	60	50	200	35	150		200	–

Loads F_{rec} and F_{eff}

Type	Concrete		Solid brick Mz 12		Solid sand-lime brick KS 12	
	F_{rec} [kN]	F_{eff} [kN]	F_{rec} [kN]	F_{eff} [kN]	F_{rec} [kN]	F_{eff} [kN]
DSH	0,09	0,6	0,07	0,5	0,07	0,5
DSH-M	0,16	1,1	0,13	0,9	0,14	1,0

F_{rec} : Recommended loads incl. safety factor of 7

F_{eff} : Effective pull out loads / ultimate loads excl. safety factors

Insulation plate DST & DSH-T



Advantages

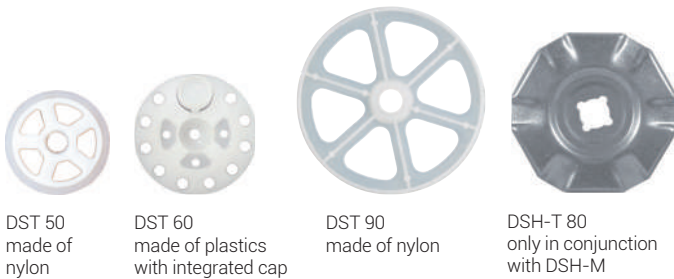

DST 50 made of nylon
 DST 60 made of plastics with integrated cap
 DST 90 made of nylon
 DSH-T 80 only in conjunction with DSH-M

- The insulation discs are suitable for installation of pressure resistant as well as soft insulation materials with frame anchors, quick-fix nails or nail plugs, as well the DSH-M insulation support

Suitable building materials



Depending on the plug or screw used

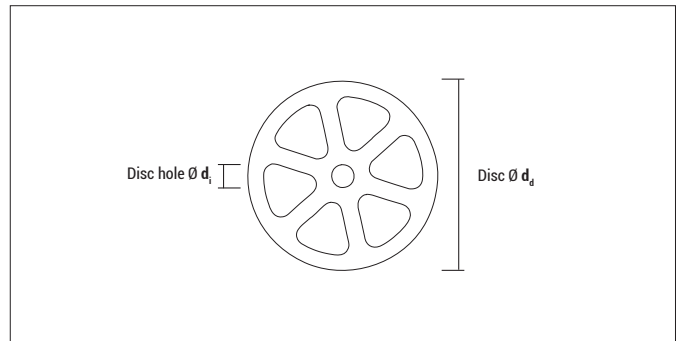

DST

HALOGEN FREE

Type	Art-No	d _d [mm]	d _i [mm]	Suitable for		€ / 100 pcs	[pcs]	[pcs]
				Type	see page			
DST 50	950DST	50	9	Nail plug NP 8	50	250	-	
				Quick-fix nail BN 8	56			
				Frame plug MFR 8, HBR 8	43			
				Screws	205			
DST 60	960DST	60	6	Nail plug NPC 5 and 6, NP 5 and 6	50	200	-	
				Quick-fix nail BN 6	56			
				Screws	205			
DST 90	990DST	90	8,5	Nail plug NP 8	50	250	-	
				Quick-fix nail BN 8	56			
				Frame plug MFR 8, HBR 8	43			
				Screws	205			

DSH-T

Type	Art-No	d _d [mm]	d _i [mm]	Suitable for	€ / 100 pcs	[pcs]	[pcs]
				Type	see page		
DSH-T 80	980DSHT	80	14	Insulation support DSH-M	82	250	-

Insulation fastener IPD



Advantages



IPD 8 with steel nail



IPD 10 with plastic nail (glass fibre reinforced)

- ETA approved for ETICS (external thermal insulation composite systems)
- Suitable for fastening solid insulation boards
- The textured surface of the plate provides a good bond for the plaster
- Stable design and impact resistant material prevents bending when hitting in

Suitable building materials

Very suitable



- Concrete
- Solid brick
- Solid sand-lime brick
- Lightweight solid concrete blocks
- Aerated concrete



- Hollow brick
- Hollow sand-lime brick
- Lightweight hollow concrete blocks
- Natural stone



Approvals and certificates



European Technical Assessment for ETICS



Mounting

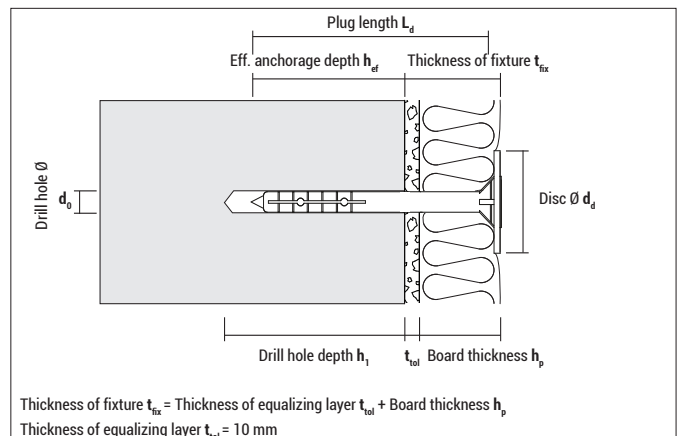
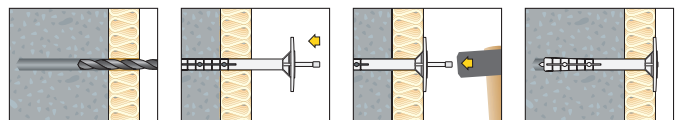

Insulation fastener IPD



IPD 8 with steel nail

Type	Art-No	d ₀ [mm]	h ₁ ≥ [mm]	h _{ef} ≥ * [mm]	L _d [mm]	d _d [mm]	t _{fix} ≤ [mm]	ETA	€/100 pcs	[pcs]	[pcs]
IPD 8x95	9895IPD	8	35	25	95	60	70	●		200	–
IPD 8x115	98115IPD	8	35	25	115	60	90	●		200	–
IPD 8x135	98135IPD	8	35	25	135	60	110	●		200	–
IPD 8x155	98155IPD	8	35	25	155	60	130	●		200	–
IPD 8x175	98175IPD	8	35	25	175	60	150	●		200	–
IPD 8x195	98195IPD	8	35	25	195	60	170	●		200	–

* Setting depth h_{ef} = 65 mm for aerated concrete, which reduces the thickness of fixture t_{fix} accordingly



IPD 10 with plastic nail (glass-fibre reinforced)

Type	Art-No	d ₀ [mm]	h ₁ ≥ [mm]	h _{ef} ≥ * [mm]	L _d [mm]	d _d [mm]	t _{fix} ≤ [mm]	ETA	€/100 pcs	[pcs]	[pcs]
IPD 10x70	91070IPD200	10	40	30	70	60	40	●		200	–
IPD 10x90	91090IPD200	10	40	30	90	60	60	●		200	–
IPD 10x110	910110IPD200	10	40	30	110	60	80	●		200	–
IPD 10x120	910120IPD200	10	40	30	120	60	90	●		200	–
IPD 10x140	910140IPD200	10	40	30	140	60	110	●		200	–
IPD 10x160	910160IPD200	10	40	30	160	60	130	●		200	–
IPD 10x180	910180IPD200	10	40	30	180	60	150	●		200	–
IPD 10x200	910200IPD200	10	40	30	200	60	170	●		200	–
IPD 10x220	910220IPD100	10	40	30	220	60	190	●		100	–
IPD 10x260	910260IPD100	10	40	30	260	60	230	●		100	–

* Setting depth h_{ef} = 50 mm for aerated concrete, which reduces the thickness of fixture t_{fix} accordingly

Loads F_{per} according to ETA

Type	Concrete C12/15 F _{per} [kN]	Concrete ≥ C20/25 F _{per} [kN]	Solid brick Mz F _{per} [kN]	Solid sand-lime brick KS F _{per} [kN]	Hollow sand-lime brick KSL F _{per} [kN]	Hollow brick HLz F _{per} [kN]	Aerated concrete AAC2 F _{per} [kN]
IPD 8	0,17	0,25	0,25	0,25	0,25	0,20	0,25
IPD 10	0,17	0,25	0,25	0,20	0,20	0,20	0,17

F_{per}: Permissible loads according to ETA assessment incl. safety factors
The safety coefficients are 2,0 and 1,5

Example of anchor arrangement for polystyrene hard foam boards 800x625mm, 1000x500mm

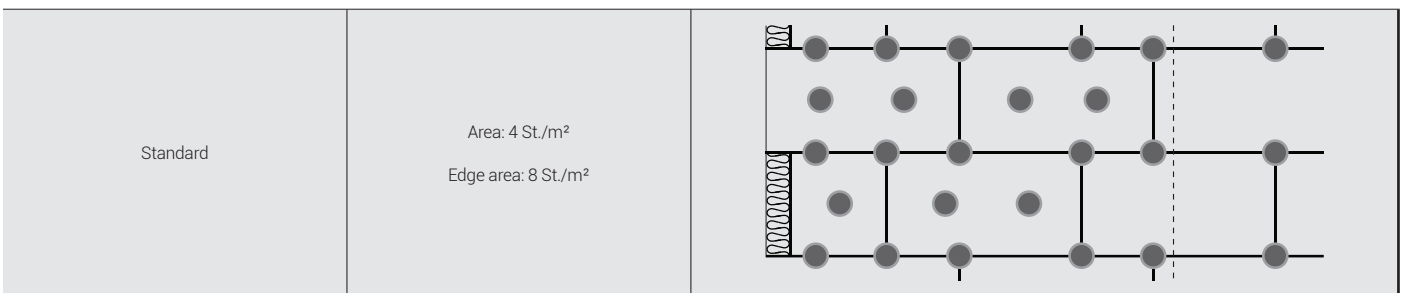





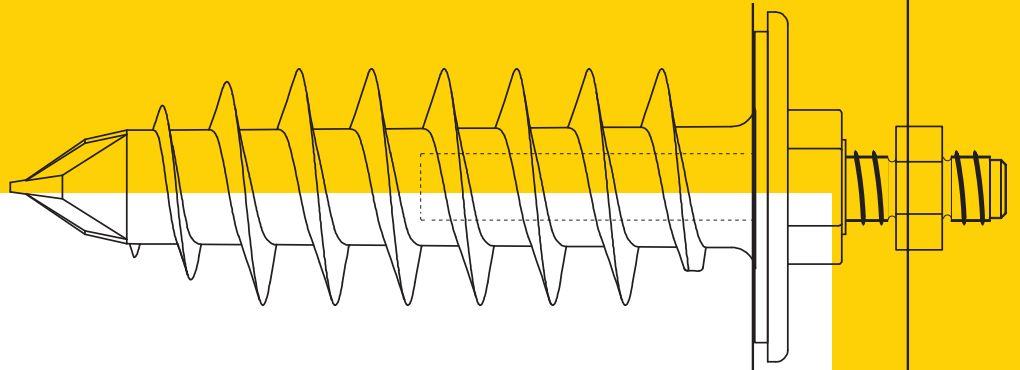

For other types of insulation boards, please contact the manufacturer

Edge zone | Normal zone



Fixing to insulated façades

IPL		88
IPL 95DS		90
IPS 80		92
IPSZ 80		94
IPSD 80		96
IPS 80 T		98
IPS-H 55		100
IPSZ-H 55		102
IPSD-H 55		104

Insulation plug IPL

Advantages



IPL 60



IPL 95

- Special plug for light duty fixings in external insulation composite systems, like letterboxes, lamps, etc.
- Direct fastening into the insulation material - no thermal bridge
- No predrilling necessary due to sharp cutting tip; also drills reliably through hard ETICS plaster (≤ 7 mm)
- Nylon plug ageing and weather resistant
- Duo-Bit: One bit for plug (IPL 60) and screw; saves installation time and money because no bit change is necessary. PZ2/TX40, TX20/TX40 and TX25/TX40 available

Suitable building materials

Very suitable



- External Thermal Insulation Composite Systems (ETICS)
- Polystyrene boards
- Hard foam boards
- Heraklith boards
- Wood fibre insulation boards (pre-drilling: 8 mm for IPL60, 13 mm for IPL95, HSS-drill or wood drill recommended)

Approvals and certificates



Mounting

Mounting IPL 60

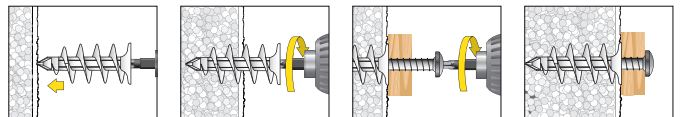

Mounting IPL 95

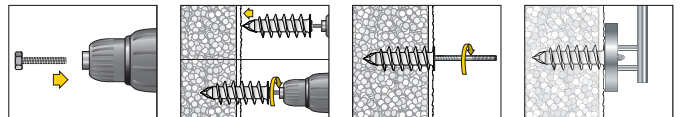

Recommendation: Seal plug collar after setting with silicone/acryl to prevent the entry of water into the insulation material.
Use **CELO StickFX CL p. 204**

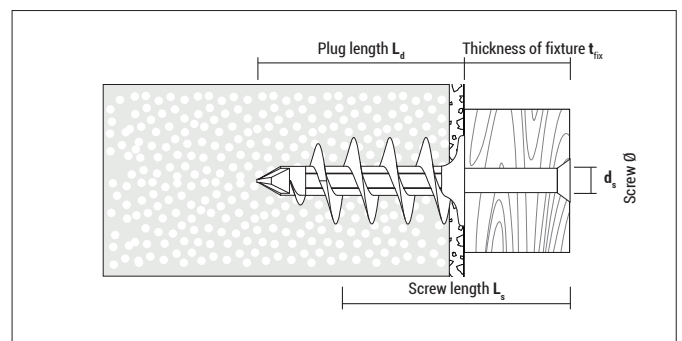

Insulation plug IPL



IPL

Type	Art-No	L _d [mm]	I _s [mm]	Recess	d _s [mm]	L _s [mm]	€ / 100 pcs	[pcs]	[pcs]
IPL 60	960IPL	58	30 - 50	TX 40	4,5 - 5,0	30 + t _{fix}		25	300
IPL 95	995IPL	95	40 - 80	SW 13	8 / 10 / M8	40 + t _{fix}		25	200

IPL 60: Head-Ø 25 mm

IPL 95: Head-Ø 32 mm, **incl. 1x screw M8 x 30 as setting tool**



Blister IPL



Type	Art-No	L _d [mm]	I _s [mm]	Recess	d _s [mm]	L _s [mm]	€ / Blister	[pcs]	[Blister]
IPL 60	560IPL4	58	30 - 50	TX 40	4,5 - 5,0	30 + t _{fix}		4	10
IPL 95	595IPL2	95	40 - 80	SW 13	8 / 10 / M8	40 + t _{fix}		2	10

IPL 60: Head-Ø 25 mm

IPL 95: Head-Ø 32 mm, **incl. 1x screw M8 x 30 as setting tool**



Blister IPL incl. screw PZ2



Type	Art-No	L _d [mm]	I _s [mm]	Recess	d _s x L _s [mm]	Type of screw	€ / Blister	[pcs]	[Blister]
IPL 60	560IPLPZ4	58	30 - 50	TX 40	4,5 x 40			4	10



Duo-Bit for IPL 60

Type	Art-No	Dimensions	For use with	€ / pc	€ / Blister	[pcs]	[Blister]
TX20/TX40	7DTX20TX40	1/4" x 43 mm	IPL60 and TX20 screw			2	10
TX25/TX40	7DTX25TX40	1/4" x 43 mm	IPL60 and TX25 screw			2	10
PZ2/TX40	7DPZ2TX40	1/4" x 43 mm	IPL60 and PZ2 screw			2	10

2 pcs packed in a robust plastic box with EURO-punching

Loads and dimensions

Type	Applications in Polystyrene EPS (PS15, PS20)	Applications in Polystyrene XPS	Application in Rockwool, Coverrock Plus plastered and unplastered	For use with	Screw insertion depth	
	F _{rec} [kN]	F _{rec} [kN]	F _{rec} [kN]		min. [mm]	max. [mm]
IPL 60	0,07	0,14	0,04 ¹⁾	Chipboard screws Ø 4,5 - 5,0	30	50
IPL 95	0,14	0,28	0,05 ¹⁾	Hanger bolts Ø8, Ø10 and M8 Screws	40	80

F_{rec}: Recommended load in all directions incl. safety factor of 5

¹⁾ Avoid impact loads

Insulation plug IPL 95DS

Advantages



- Perfect solution for fastening downpipes in ETICS: simple, flexible, fast and adjustable!
- Direct fastening into the insulation material - no thermal bridge
- Pre-mounted special threaded stud: ideal distance of 30 mm of the rainwater downpipe from the wall; adjustment of further 25 mm possible
- Pre-assembled and weather resistant EPDM sealing ensures clean sealing against driving rain up to wind force 11 (violent storm), tested according to DIN EN 1027, no reworking required
- Self-drilling (ETICS plaster ≤ 7 mm) and robust nylon plug, ageing resistant
- Special threaded stud made out of stainless steel A2 or zinc flake coating for optimal corrosion resistance

Suitable building materials

Very suitable



- External Thermal Insulation Composite Systems (ETICS)
- Hard foam boards
- Polystyrene boards
- Heraklith boards
- Wood fibre insulation boards (pre-drilling: 13 mm, HSS-drill or wood drill recommended)



Approvals and certificates



Tested for driving rain tightness by the Prüfzentrum für Bauelemente (Germany)

Mounting

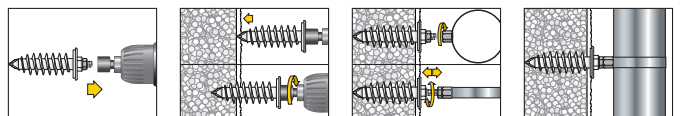

- The IPL 95DS can be installed with a hexagon SW17 (recommended), hexagon SW13 socket or TX25 bit
- The special threaded stud can be adjusted up to 25 mm.
- Tip: If the plug should rotate, fixate it with a wrench SW17.

Insulation plug IPL 95DS

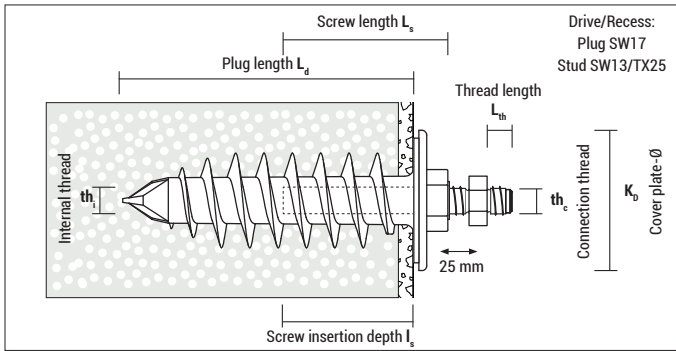

IPL 95DS, zinc flake coated

Type	Art-No	L _d [mm]	I _s [mm]	th ₁ x L _s [mm]	th _c x L _{th} [mm]	K _D [mm]	Material threaded stud	€/ 100 pcs	[pcs]	[pcs]
IPL 95DS M8	ZG895IPLDS4	95	20 - 50	M10 x 60	M8 x 8	44,5	Zinc flake coating		4	80
IPL 95DS	ZG95IPLDS4	95	20 - 50	M10 x 60	M10 x 8	44,5	Zinc flake coating		4	80

Packed by 4 pcs incl. installation instruction in a bag



IPL 95DS, stainless steel A2



Type	Art-No	L _d [mm]	I _s [mm]	th ₁ x L _s [mm]	th _c x L _{th} [mm]	K _D [mm]	Material threaded stud	€/ 100 pcs	[pcs]	[pcs]
IPL 95DS M8 A2	X895IPLDS4	95	20 - 50	M10 x 60	M8 x 8	44,5	Stainless steel A2		4	80
IPL 95DS A2	X95IPLDS4	95	20 - 50	M10 x 60	M10 x 8	44,5	Stainless steel A2		4	80

Packed by 4 pcs incl. installation instruction in a bag



IPL 95D

Type	Art-No	L _d [mm]	I _s [mm]	th ₁ x L _s [mm]	Drive	K _D [mm]	€/ 100 pcs	[pcs]	[pcs]
IPL 95D	995IPLD	95	20 - 50	M10 x 60	SW17	44,5		20	160

Loads and dimensions

Type	Applications in Polystyrene EPS (PS15, PS20) F _{rec} [kN]	Applications in Polystyrene XPS F _{rec} [kN]	Special threaded stud	Screw insertion depth I _s	
				min [mm]	max [mm]
IPL 95DS / IPL 95D	0,14	0,28	Total length 60 mm Thread inside the plug: 50 mm	20	50

F_{rec}: Recommended load in all directions incl. safety factor of 5

Insulation screw **IPS 80**

Advantages



- Special screw for direct fastening into external thermal insulation composite systems (ETICS) - extremely fast and without thermal bridges!
- For fastening of wall connection profiles, metal sheets, base protection profiles, cornice covers, motion detectors, lamps, signs, etc. into the insulation material
- No pre-drilling in plaster (≤ 7 mm) due to sharp drilling tip
- Special screw made out of glass-fibre reinforced nylon with EPDM sealing; ageing, weather and UV-resistant
- Pre-assembled and weather resistant EPDM sealing ensures clean sealing against driving rain up to wind force 11 (violent storm), tested according to DIN EN 1027, no reworking required
- Stylish flat head, different colors
- Suitable for clearance holes $\geq \text{Ø } 8$ mm (common for wall profiles)
- Also suitable for light duty fixings in combination with a screw $\text{Ø } 3,5$ mm

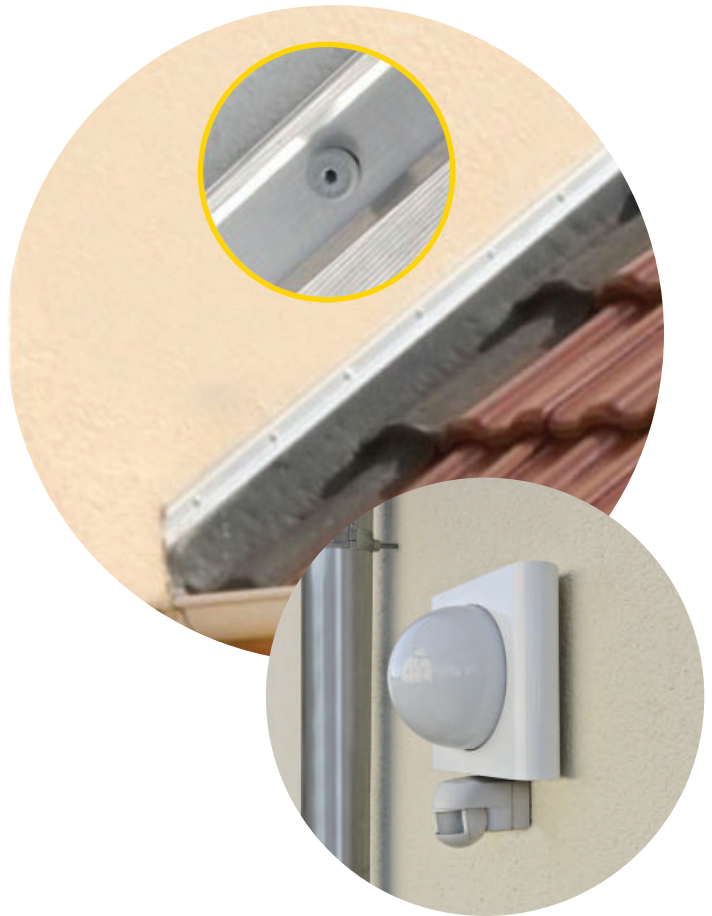

Suitable building materials

Very suitable



- External Thermal Insulation Composite Systems (ETICS)
- Styrofoam boards
- Hard foam boards
- Polystyrene boards
- Wood fibre boards (IPS-H, see page 100, is recommended)

Approvals and certificates



Tested for driving rain tightness by the Prüfzentrum für Bauelemente (Germany)



Insulation screw IPS 80

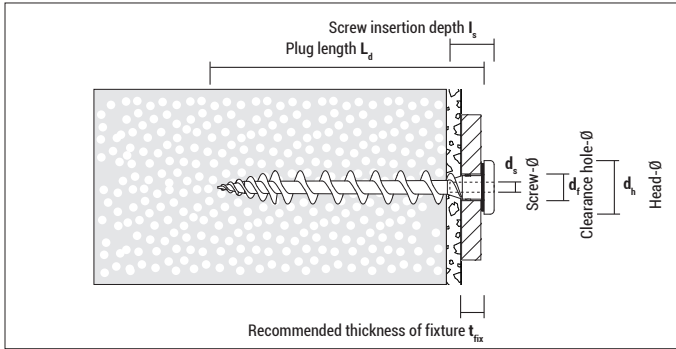

Mounting

Wall connection profiles

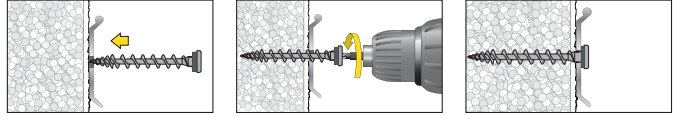

Light duty fixings with screw

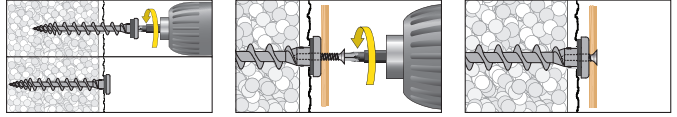

Usable with: Screw Ø 3,5 mm;
Screw length L_s = 10 mm + Thickness of fixture



IPS 80 with EPDM sealing

Type	Art-No	RAL-Code	L _d [mm]	d _h [mm]	I _s [mm]	d _s [mm]	t _{fix} [mm]	Drive	d _r [mm]	€ / 100 pcs	[pcs]	[pcs]
IPS 80 Signal white	9180IPS	RAL 9003	80	16	10	3,5	≤ 10	TX 25	8 – 10		50	900
IPS 80 Telegrey	9GR80IPS	RAL 7045	80	16	10	3,5	≤ 10	TX 25	8 – 10		50	900
IPS 80 Anthracite grey	9AN80IPS	RAL 7016	80	16	10	3,5	≤ 10	TX 25	8 – 10		50	900
IPS 80 Traffic black	9480IPS	RAL 9017	80	16	10	3,5	≤ 10	TX 25	8 – 10		50	900
IPS 80 Copper brown	9CO80IPS	RAL 8004	80	16	10	3,5	≤ 10	TX 25	8 – 10		50	900
IPS 80 Sepia brown	9M80IPS	RAL 8014	80	16	10	3,5	≤ 10	TX 25	8 – 10		50	900
IPS 80 Chocolate brown	9MO80IPS	RAL 8017	80	16	10	3,5	≤ 10	TX 25	8 – 10		50	900



Blister IPS 80 incl. screws made of stainless steel A2, PH2



Type	Art-No	L _d [mm]	Plug Recess	d _r [mm]	d _s x L _s [mm]	Type of screw	€ / Blister	[pcs]	[Blister]
IPS 80 PH	5180IPSPH4	80	TX 25	8 – 10	3,5 x 13 + 3,5 x 16			4	10

Loads and dimensions

Type	Applications in Polystyrene EPS [PS15, PS20] unplastered	Applications in Polystyrene EPS [PS15, PS20] plastered	Application in Rockwool, Coverrock Plus unplastered	Applications in Polystyrene XPS [perimeter insulation] unplastered	Thickness of insulation material ≥ [mm]
IPS 80	F _{rec} [kN] 0,04	F _{rec} [kN] ca. 0,06*	F _{rec} [kN] 0,02 ¹⁾	F _{rec} [kN] 0,09*	80

F_{rec}: Recommended load in all directions incl. safety factor of 5

* Value may differ depending on the type and thickness of the plaster

¹⁾ Avoid impact loads

Insulation screw IPSZ 80

Advantages



IPSZ 80, zinc die casting

- Special screw for direct fastening into external thermal insulation composite systems (ETICS) - fast and without thermal bridges!
- For fastening of wall connection profiles, metal sheets, base protection profiles, cornice covers, motion detectors, lamps, signs, etc. into the insulation material
- No pre-drilling in plaster due to sharp drilling tip
- Installation directly into aerated concrete AAC2 and AAC4 (with increased pressure) possible
- The drill tip drills through thin sheet metal
- Ageing, weather and UV-resistant EPDM sealing ensures reliable sealing
- Pre-assembled and ageing, weather and UV-resistant EPDM sealing
- EPDM sealing ensures clean sealing against driving rain up to wind force 11 (violent storm), tested according to DIN EN 1027, no reworking required
- Stylish flat head with TX-recess
- Suitable for clearance holes \varnothing 8 mm (common for wall profiles)
- Also suitable for light duty fixings in combination with a screw \varnothing 3,5 mm
- Good corrosion resistance

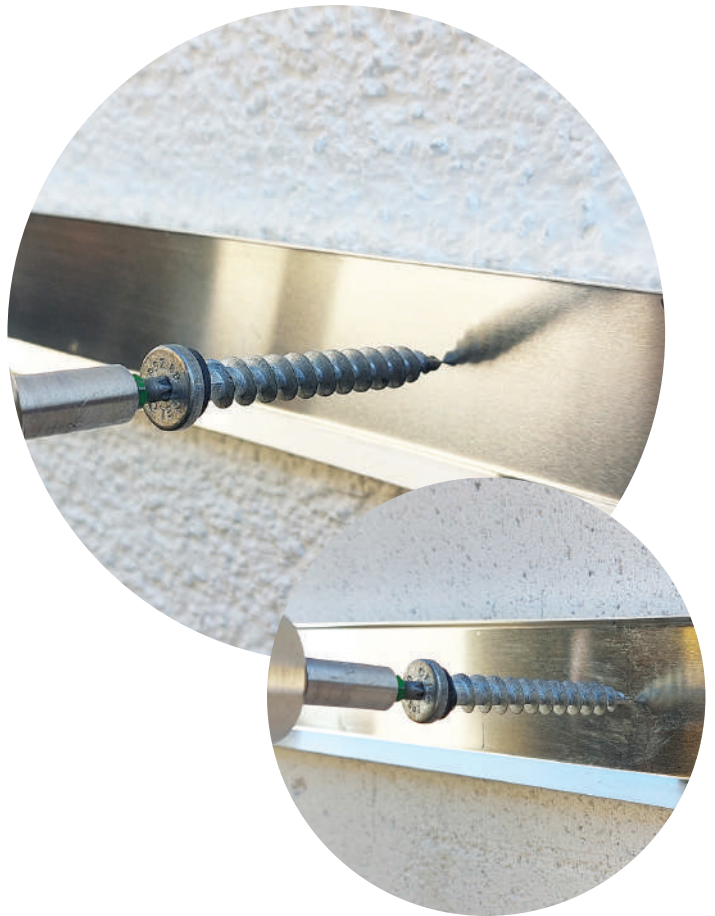

Suitable building materials

Very suitable



- External Thermal Insulation Composite Systems (ETICS)
- Styrofoam boards
- Hard foam boards
- Polystyrene boards
- Wood fibre boards and perimeter insulation (IPSZ-H, see page 102, is recommended)
- Aerated concrete AAC2
- Aerated concrete AAC4

Approvals and certificates



PfB

Tested for driving rain tightness by the Prüfstelle für Bauelemente (Germany)

Insulation screw IPSZ 80

Mounting

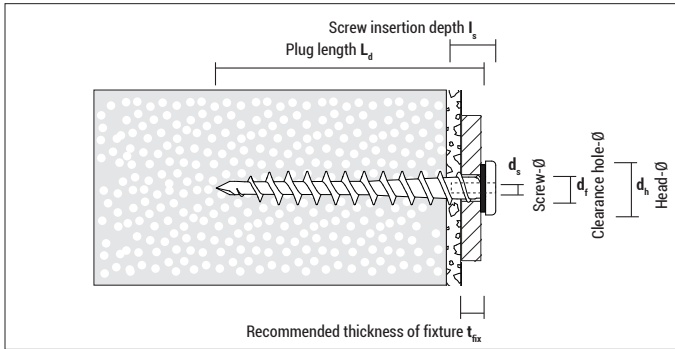

Wall connection profiles

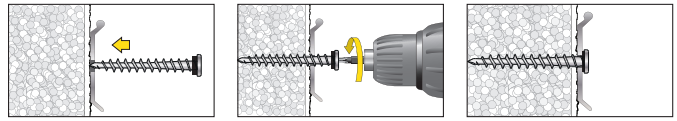

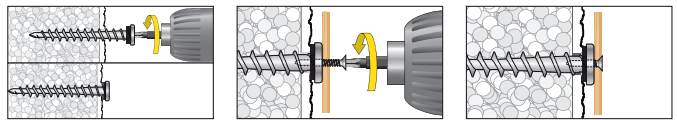

Light duty fixings with screw



Usable with: Screw \varnothing 3,5 mm;
Screw length L_s = 10 mm + Thickness of fixture



IPSZ 80 made of zinc die casting, with EPDM sealing

Type	Art-No	L_d [mm]	d_h [mm]	I_s [mm]	d_s [mm]	t_{fix} [mm]	Drive	d_f [mm]	€ / 100 pcs	 [pcs]	 [pcs]
IPSZ 80	980IPSZ	80	16	10	3,5	≤ 10	TX 25	8 – 10 *		50	900

* Soft tinsmith profiles can be drilled directly.

Loads and dimensions

Type	Applications in Polystyrene EPS (PS15, PS20) unplastered F_{rec} [kN]	Applications in Polystyrene EPS (PS15, PS20) plastered F_{rec} [kN]	Application in Rockwool, Coverrock Plus unplastered ¹⁾ F_{rec} [kN]	Applications in Polystyrene XPS (perimeter insulation) unplastered F_{rec} [kN]	Aerated concrete AAC2 F_{rec} [kN]	Aerated concrete AAC4 F_{rec} [kN]	Thickness of insulation material or brick \geq [mm]
IPSZ 80	0,04	ca. 0,06*	0,02	0,09 ¹⁾	0,23	0,27	80

F_{rec} : Recommended load in all directions incl. safety factor of 5

* Value may differ depending on the type and thickness of the plaster

¹⁾ Avoid impact loads

Insulation screw plug IPSD 80



Advantages



- Special screw plug for direct fastening into external thermal insulation composite systems (ETICS) - fast and without thermal bridges!
- For fastening of wall connection profiles, metal sheets, base protection profiles, cornice covers, motion detectors, lamps, signs, etc. into the insulation material
- To be used with plumber screws 4,5 mm
- Pre-drilling in plaster usually not necessary (≤ 7 mm) due to sharp drilling tip
- 80 mm length for a good hold in the insulation material
- Suitable for clearance holes $\geq \varnothing 8$ mm (common for wall profiles)
- Made out of robust glass-fibre reinforced nylon
- Clean sealing against driving rain up to wind force 11 (violent storm) in combination with plumber screw PLS, tested according to DIN EN 1027, no reworking required

Approvals and certificates



Suitable building materials

Very suitable



- External Thermal Insulation Composite Systems (ETICS)
- Styrofoam boards
- Hard foam boards
- Polystyrene boards
- Wood fibre boards (IPSD-H, see page 104, is recommended)

Mounting

Wall connection profiles

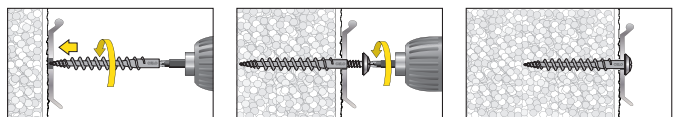

Recommended plumber screw: 4,5x25 mm

Light duty fixings with screw

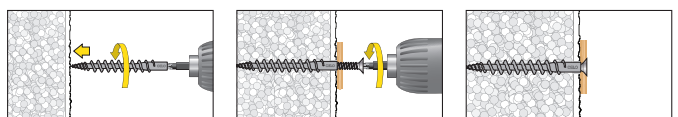

The IPSD 80 can be installed using a TX25 bit.
Usable with screw $\varnothing 4,5$ mm;
Screw length $L_s = 15 - 20$ mm + Thickness of fixture

Insulation screw plug IPSD

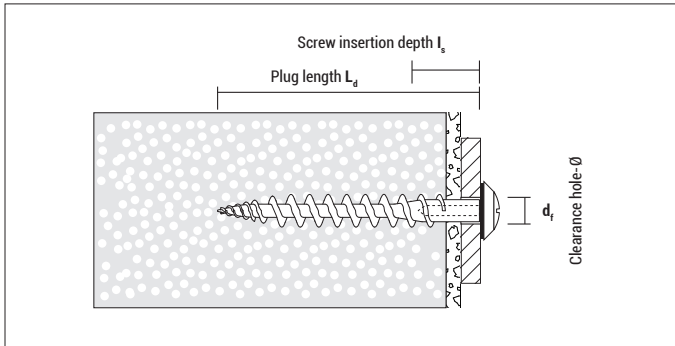

IPSD 80

Type	Art-No	L_d [mm]	I_s [mm]	Drive	d_i [mm]	€ / 100 pcs	[pcs]	[pcs]
IPSD 80	9GR80IPSD	80	20	TX 25	min. 8		50	1.350



Plumber screw PLS TX sealing washer $\varnothing = 15,0$ mm

A2
STAINLESS
STEEL

Type $d_0 \times L_s$	Art-No	Material	d_0 [mm]	L_s [mm]	Drive	€ / 100 pcs	[pcs]	[pcs]
4,5x25	9X4525PLST	stainless steel A2	4,5	25	TX 25		50	1.200
4,5x25	9XC04525PLST	stainless steel A2, copper plated	4,5	25	TX 25		50	1.200

Loads and dimensions

Type	Applications in Polystyrene EPS (PS15, PS20) unplastered F_{rec} [kN]	Applications in Polystyrene EPS (PS15, PS20) plastered F_{rec} [kN]	Application in Rockwool, Coverrock Plus unplastered F_{rec} [kN]	Applications in Polystyrene XPS (perimeter insulation) unplastered F_{rec} [kN]	Thickness of insulation material \geq [mm]
IPSD 80	0,04	ca. 0,06*	0,02	0,09	80

F_{rec} : Recommended load in all directions incl. safety factor of 5

* Value may differ depending on the type and thickness of the plaster

Insulation screw IPS 80T

Advantages



- Special screw with trumpet head for direct fastening into external thermal insulation composite systems (ETICS) - fast and without thermal bridges!
- Perfectly suitable for joining two insulation boards such as PU rigid foam boards, fastening foils or for the sheathing/insulation of ventilation ducts
- For fixing motion detectors, lighting, signs etc. in the insulation board
- No need to pre-drill into plaster (≤ 7 mm) due to the sharp drilling tip
- Special screw made out of robust glass-fibre reinforced nylon; ageing-, weather- and UV-resistant
- Functional trumpet head for flush countersinking
- Suitable for light fixings with a screw $\varnothing 3.5$ mm due to head hole

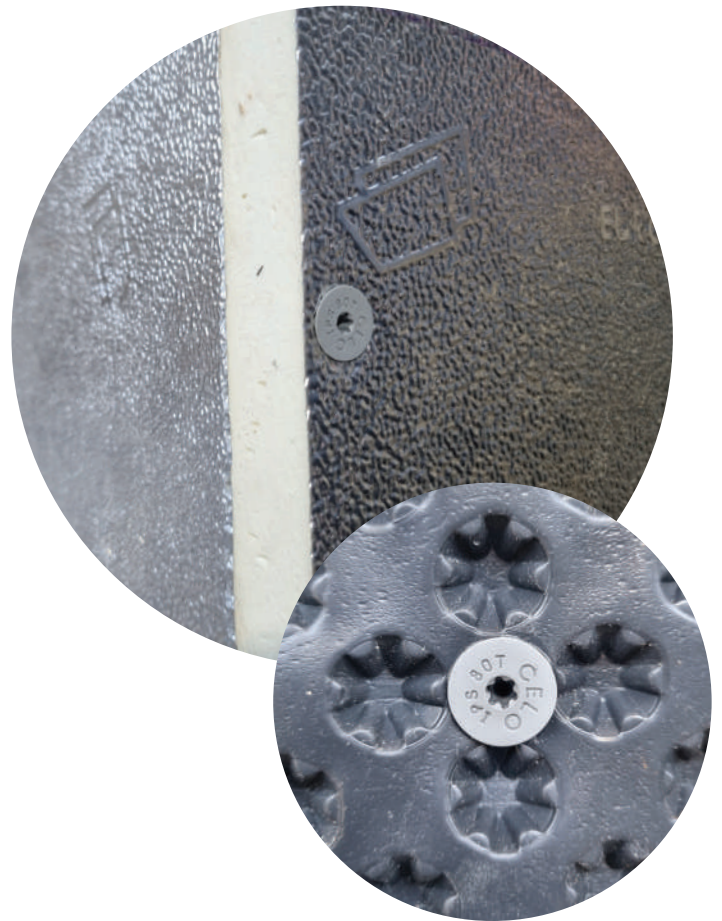

Approvals and certificates



Suitable building materials

Very suitable



- External Thermal Insulation Composite Systems (ETICS)
- Styrofoam boards
- Hard foam boards
- Polystyrene boards
- Wood fibre boards (also see IPS-H)

Mounting

Example: Joining two insulation boards

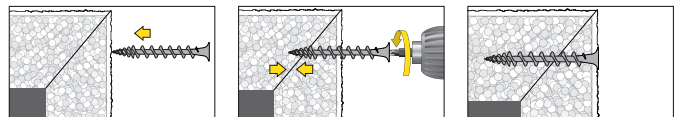

Example: Fastening insulation foil

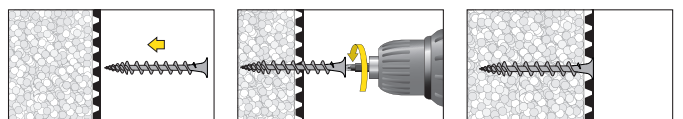

Lightweight fastening with screw

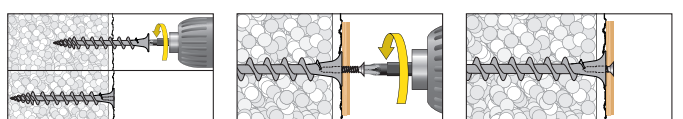

Can be used with: screw $\varnothing 3.5$ mm;
Screw length $L_s = 10$ mm + thickness of fixture

Insulation screw IPS 80T

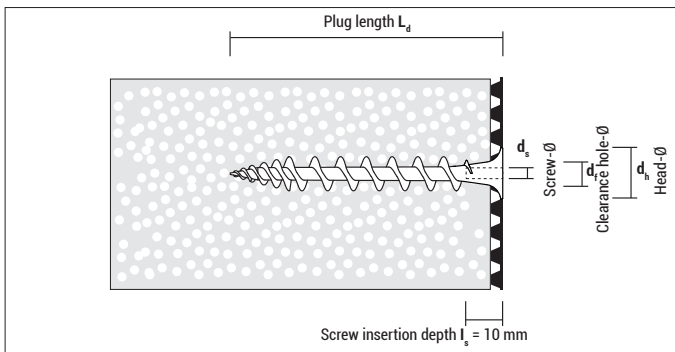

IPS 80T

Type	Art-No	RAL-Code	L_d [mm]	d_h [mm]	I_s [mm]	d_s [mm]	Drive	d_f [mm]	€ / 100 pcs	 [pcs]	 [pcs]
IPS 80T Telegrey	GGR80IPST	RAL 7045	80	16	10	3,5	TX 25	8 – 10		1.500	–

In bulk, delivery on order

Loads and dimensions

Type	Applications in Polystyrene EPS (PS15, PS20) unplastered F_{rec} [kN]	Applications in Polystyrene EPS (PS15, PS20) plastered F_{rec} [kN]	Application in Rockwool, Coverrock Plus unplastered F_{rec} [kN]	Applications in Polystyrene XPS (perimeter insulation) unplastered F_{rec} [kN]	Thickness of insulation material ≥ [mm]
IPS 80T	0,04	ca. 0,06*	0,02 ¹⁾	0,09	80

F_{rec} : Recommended load in all directions incl. safety factor of 5

* Value may differ depending on the type and thickness of the plaster

¹⁾ Avoid impact loads

Insulation screw

IPS-H 55



Advantages



- Special screw for direct fastening into wood fibre insulation boards and perimeter insulation panels - extremely fast and without thermal bridges!
- For fastening of wall connection profiles, metal sheets, base protection profiles, cornice covers, motion detectors, lamps, signs, etc. into the insulation material
- Length only 55 mm; therefore also perfectly suitable for small insulation thicknesses (from 60 mm)
- No pre-drilling in plaster (≤ 7 mm) due to sharp drilling tip
- Special screw made out of glass-fibre reinforced nylon with EPDM sealing; ageing, weather and UV-resistant
- Pre-assembled and weather resistant EPDM sealing ensures clean sealing against driving rain up to wind force 11 (violent storm), tested according to DIN EN 1027, no reworking required
- Stylish flat head, different colors
- Suitable for clearance holes $\geq \text{Ø } 8$ mm (common for wall connection profiles)
- Suitable for light duty fixings in combination with a screw $\text{Ø } 3,5$ mm

Suitable building materials

Very suitable



- Wood fibre boards
- Perimeter insulation panels

Approvals and certificates



Insulation screw IPS-H 55

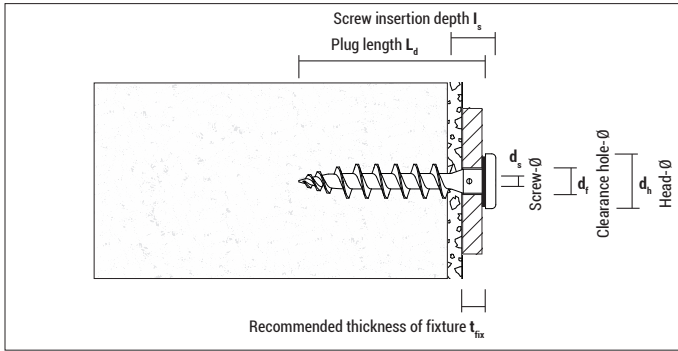

Mounting

Wall connection profiles

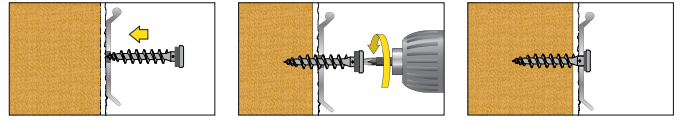

Light duty fixings with screw

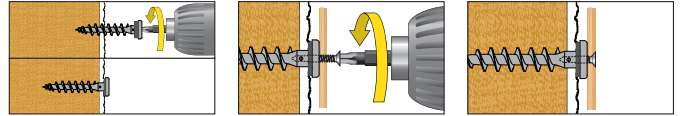

Usable with: Screw \varnothing 3,5 mm;
Screw length L_s = 10 mm + Thickness of fixture

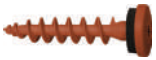

IPS-H 55 with EPDM sealing

Type	Art-No	RAL-Code	L_d [mm]	d_h [mm]	I_s [mm]	d_s [mm]	t_{fix} [mm]	Drive	d_f [mm]	€ / 100 pcs	[pcs]	[pcs]
IPS-H Signal white	9155IPSH	RAL 9003	55	16	10	3,5	≤ 10	TX 25	8 – 10		50	1.350
IPS-H Telegrey	9GR55IPSH	RAL 7045	55	16	10	3,5	≤ 10	TX 25	8 – 10		50	1.350
IPS-H Anthracite grey	9AN55IPSH	RAL 7016	55	16	10	3,5	≤ 10	TX 25	8 – 10		50	1.350
IPS-H Traffic black	9455IPSH	RAL 9017	55	16	10	3,5	≤ 10	TX 25	8 – 10		50	1.350
IPS-H Copper brown	9CO55IPSH	RAL 8004	55	16	10	3,5	≤ 10	TX 25	8 – 10		50	1.350
IPS-H Sepia brown	9M55IPSH	RAL 8014	55	16	10	3,5	≤ 10	TX 25	8 – 10		50	1.350
IPS-H Chocolate brown	9MO55IPSH	RAL 8017	55	16	10	3,5	≤ 10	TX 25	8 – 10		50	1.350

Loads and dimensions

Type	Applications in wood fibre insulation boards unplastered F_{rec} [kN]	Applications in wood fibre insulation boards plastered F_{rec} [kN]	Applications in Polystyrene XPS (perimeter insulation) unplastered F_{rec} [kN]	Thickness of insulation material ≥ [mm]
IPS-H 55	0,10*	ca. 0,12*	0,07	60

F_{rec} : Recommended load in all directions incl. safety factor of 5

* Value may differ depending on wood fibre board type as well as type and thickness of the plaster

Insulation screw

IPSZ-H 55



Advantages



IPSZ-H 55, zinc die casting

- Special screw for direct fastening into wood fibre insulation boards and perimeter insulation panels - extremely fast and without thermal bridges!
- For fastening of wall connection profiles, metal sheets, base protection profiles, cornice covers, motion detectors, lamps, signs, etc. into the insulation material
- Length only 55 mm; therefore also perfectly suitable for small insulation thicknesses (from 60 mm)
- No pre-drilling in plaster due to sharp drilling tip
- Installation directly into aerated concrete AAC2 and AAC4 (with increased pressure) possible
- The drill tip drills through thin sheet metal
- Pre-assembled and ageing, weather and UV-resistant EPDM sealing
- EPDM sealing ensures clean sealing against driving rain up to wind force 11 (violent storm), tested according to DIN EN 1027, no reworking required
- Stylish flat head with TX-recess
- Suitable for clearance holes \varnothing 8 mm (common for wall profiles)
- Also suitable for light duty fixings in combination with a screw \varnothing 3,5 mm
- Good corrosion resistance

Suitable building materials

Very suitable



- Wood fibre boards
- Perimeter insulation panels



- Aerated concrete AAC2
- Aerated concrete AAC4

Approvals and certificates



Tested for driving rain tightness by the Prüfzentrum für Bauelemente (Germany)



Insulation screw IPSZ-H 55

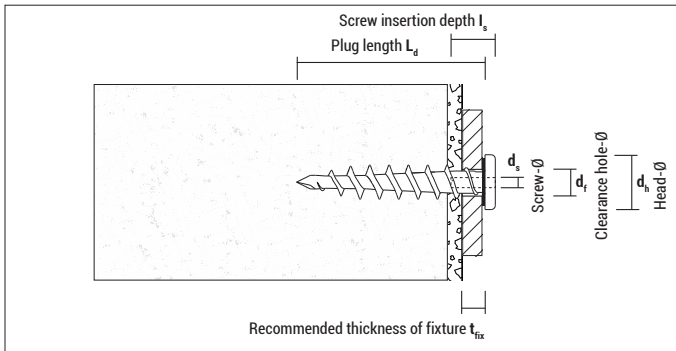

Mounting

Wall connection profiles

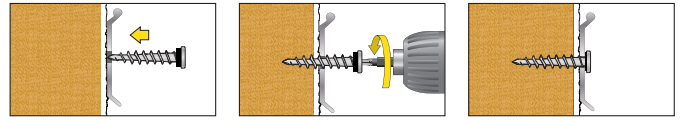

Light duty fixings with screw

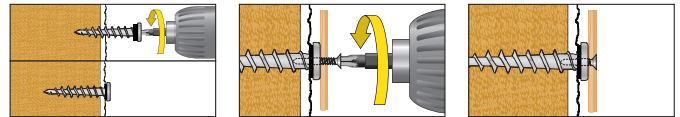

Usable with: Screw \varnothing 3,5 mm;
Screw length $L_s = 10$ mm + Thickness of fixture



IPSZ-H made of zinc die casting, with EPDM sealing

Type	Art-No	L_d [mm]	d_h [mm]	I_s [mm]	d_s [mm]	t_{fix} [mm]	Drive	d_r [mm]	€ / 100 pcs	[pcs]	[pcs]
IPSZ-H 55	955IPSZH	55	16	10	3,5	≤ 10	TX 25	8 - 10 *		50	900

* Soft tinsmith profiles can be drilled directly.

Loads and dimensions

Type	Applications in wood fibre insulation boards unplastered F_{rec} [kN]	Applications in wood fibre insulation boards plastered F_{rec} [kN]	Applications in Polystyrene XPS [perimeter insulation] unplastered F_{rec} [kN]	Aerated concrete AAC2 F_{rec} [kN]	Aerated concrete AAC4 F_{rec} [kN]	Thickness of insulation material or brick \geq [mm]
IPSZ-H 55	0,10*	ca. 0,12*	0,07	0,16	0,25	60

F_{rec} : Recommended load in all directions incl. safety factor of 5

* Value may differ depending on wood fibre board type as well as type and thickness of the plaster

Insulation screw plug IPSD-H 55



Advantages



- Special screw plug for direct fastening into wood fibre insulation boards - extremely fast and without thermal bridges!
- For fastening of wall connection profiles, metal sheets, base protection profiles, cornice covers, motion detectors, lamps, signs, etc. into the insulation material
- To be used with plumber screws 4,5x25 mm
- Pre-drilling in plaster usually not necessary (≤ 7 mm) due to sharp drilling tip
- Length only 55 mm; therefore also perfectly suitable for small insulation thicknesses (from 60 mm)
- Suitable for clearance holes $\geq \varnothing 8$ mm (common for wall connection profiles)
- Made out of glass-fibre reinforced nylon
- Clean sealing against driving rain up to wind force 11 (violent storm) in combination with plumber screw PLS, tested according to DIN EN 1027, no reworking required

Approvals and certificates



Suitable building materials

Very suitable



- Wood fibre boards
- Perimeter insulation panels

Mounting

Wall connection profiles

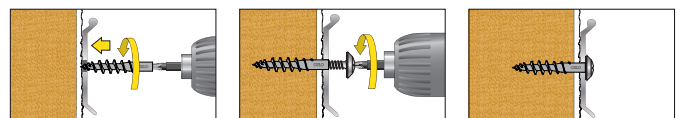

Recommended plumber screw: 4,5x25 mm

Light duty fixings with screw

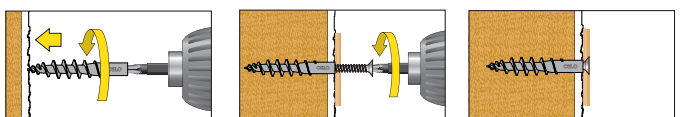

Usable with: Screw $\varnothing 4,5$ mm;
Screw length $L_s = 10$ mm + Thickness of fixture

Insulation screw plug IPSD-H

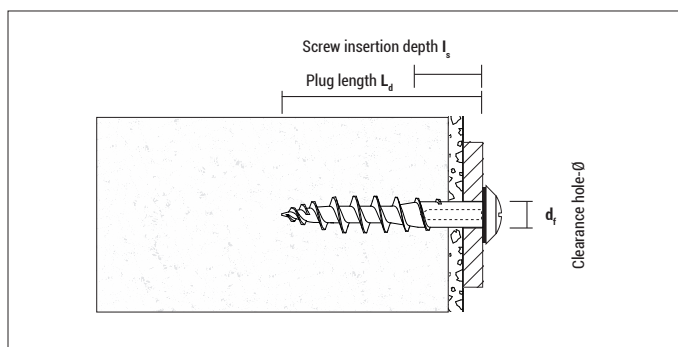
IPSD-H 55

Type	Art-No	L_d [mm]	I_s [mm]	Drive	d_f [mm]	€ / 100 pcs	[pcs]	[pcs]
IPSD-H	9GR55IPSDH	55	20	TX 25	min. 8		50	1.350

Plumber screw PLS TX sealing washer $\varnothing = 15,0$ mm

A2
STAINLESS
STEEL

Type $d_0 \times L_s$	Art-No	Material	d_0 [mm]	L_s [mm]	Drive	€ / 100 pcs	[pcs]	[pcs]
4,5x25	9X4525PLST	Stainless steel A2	4,5	25	TX 25		50	1.200
4,5x25	9XCO4525PLST	Stainless steel A2, copper plated	4,5	25	TX 25		50	1.200

Loads and dimensions

Type	Applications in wood fibre insulation boards unplastered F_{rec} [kN]	Applications in wood fibre insulation boards plastered F_{rec} [kN]	Applications in Polystyrene XPS (perimeter insulation) F_{rec} [kN]	Thickness of insulation material \geq [mm]
IPSD-H	0,10*	ca. 0,12*	0,07*	60

 F_{rec} : Recommended load in all directions incl. safety factor of 5

* Value may differ depending on wood fibre board type as well as type and thickness of the plaster

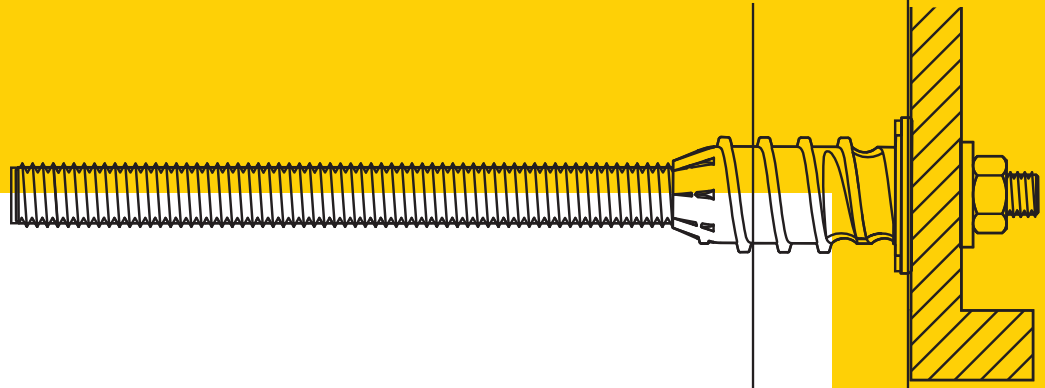

Distance mounting system ResiTHERM®

ResiTHERM® 16 & 12



107

ResiTHERM® 37



116

ResiTHERM® 37S



119

Distance mounting system

ResiTHERM®

16 & 12

Advantages



- The perfect solution for mounting heavy loads on insulated façades without thermal bridges
- Suitable for concrete, aerated concrete and masonry made of perforated and solid bricks
- Wide range of applications, such as awnings, canopies, french balconies, satellite dishes, air conditioners, etc.
- High application flexibility: One set for all insulation types and thicknesses from 60-300 mm in concrete and 60-250 mm in perforated bricks (ResiTHERM® 16), from 60-220 mm in concrete and 60-160 mm in perforated bricks (ResiTHERM® 12)
- Time and cost savings due to simple and quick installation
- Reliable, durable, ETA-tested fixing
- Thermal separation module eliminates heat bridges efficiently and protects against mould and heat loss
- Pre-assembled, weather resistant EPDM sealing ensures safe sealing against driving rain up to wind force 11 (violent storm) and up to 3 mm displacement, watertightness based on DIN EN 1027
- No risk of corrosion due to high-quality materials such as stainless steel A4 and glass-fibre reinforced nylon

Suitable building materials

Very suitable

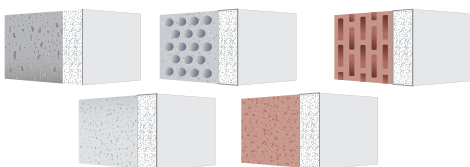

- Concrete
- Solid brick
- Solid sand-lime brick
- Lightweight solid concrete blocks
- Aerated concrete
- Hollow brick
- Hollow sand-lime brick
- Lightweight hollow concrete blocks
- Natural stone (risk of discolouration)



Approvals and certificates



Mounting

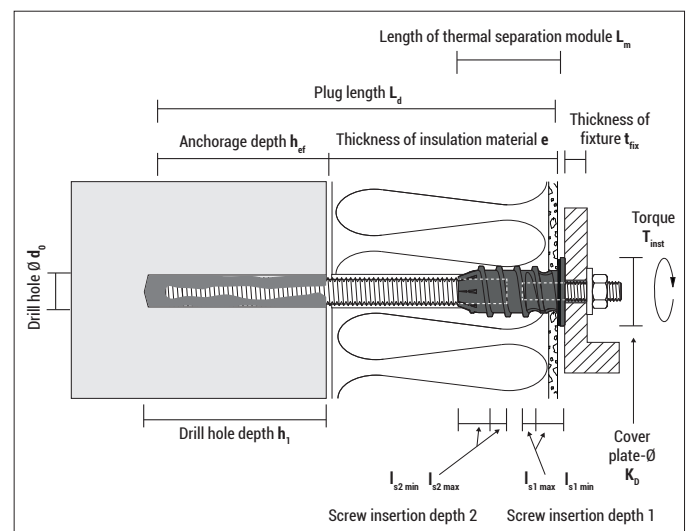

Mounting in concrete

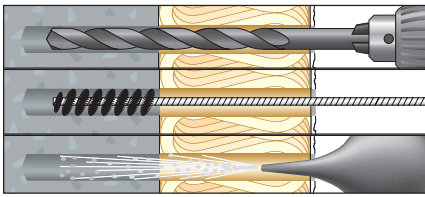

1. Drill a hole: Drill hole depth + insulation thickness
2. Clean the drill hole properly according to ETA:
4x blow - 4x brush - 4x blow

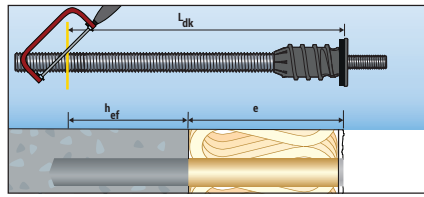

3. Cut the ResiTHERM® 16 or 12 to length:
After determining the correct length, cut the threaded rod to length with a metal saw or similar.

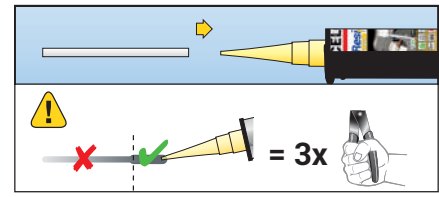

4. Attach the mixing nozzle extension MDV to the mixing nozzle MD.
Squeeze out the injection mortar until the mortar has a uniform grey mixing colour - discard the pre-run of the first at least 3 strokes.

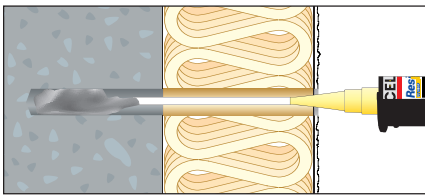

5. Fill at least 2/3 of the drill hole with composite mortar (start from the beginning). For number of strokes see mounting instructions at www.celofixings.com.
Important: Follow the installation instructions and processing time of the ResiFIX injection mortar used in accordance with the approval/assessment.

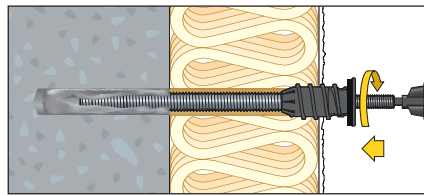

6. Screw in the ResiTHERM® 16 or 12 with the hexagon bit (included) and a cordless screwdriver until the seal is pressed against the plaster.
Note: The thermal separation module drills itself through the insulation (additional sealing is not necessary, unless the plaster is very rough)

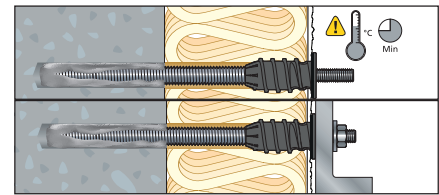

7. Observe curing time of the injection system, see cartridge label of the ResiFIX injection mortar.
8. Afterwards, the attachment can be mounted, max. torque $T_{inst} = 25 \text{ Nm}$ (ResiTHERM® 16) or 19 Nm (ResiTHERM® 12)

Mounting in masonry [hollow brick]

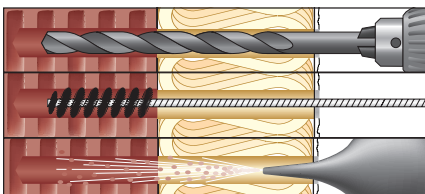

1. Drill a hole: Drill hole diameter = 20 mm.
Drill hole depth $\geq 140 \text{ mm}$ + insulation thickness (incl. plaster). Observe the drilling procedure of the approval/ assessment of ResiFIX injection mortar.
Perforated bricks and aerated concrete: Rotary drilling - without impact
2. Clean the drill hole properly according to ETA:
2x blow - 2x brush - 2x blow

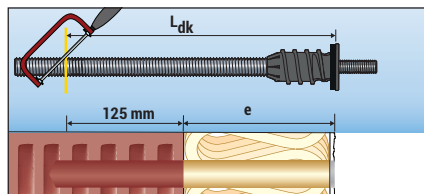

3. Cut the ResiTHERM® 16 or 12 to length:
Correct length L_{dk} : Anchorage depth in plastic sleeve (125 mm) + insulation thickness e (incl. plaster)
After determining the correct length, cut the threaded rod to length with a metal saw or similar.

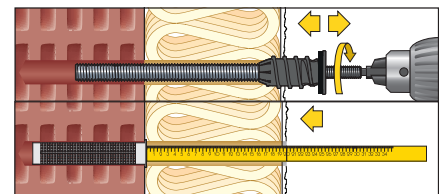

4. Enlarge the opening in the plaster for the collar of the plastic sleeve to 26 mm. To do this, briefly screw the thermal separation module in and out through the plaster for only approx. 2 thread turns or ream the plaster with a drill or drill with a bigger 26 mm drill.
5. Push the plastic sleeve into the drill hole with the help of a folding ruler or similar.

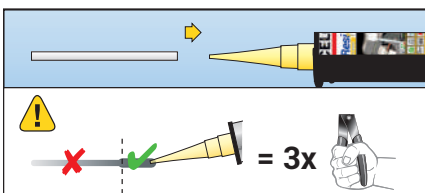

6. Attach the mixing nozzle extension MDV to the mixing nozzle MD.
Squeeze out the injection mortar until the mortar has a uniform grey mixing colour - discard the pre-run of the first at least 3 strokes.

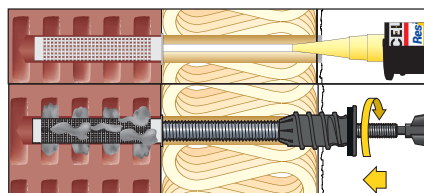

7. Fill the plastic sleeve completely with composite mortar (start from the beginning). For number of strokes see mounting instructions at www.celofixings.com
Important: Follow the installation instructions and processing time of the ResiFIX injection mortar used in accordance with the approval/assessment.

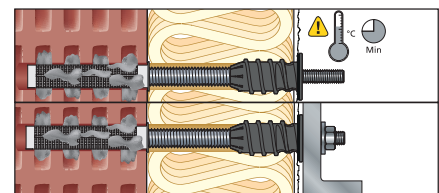

8. Screw in the ResiTHERM® 16 or 12 with the hexagon bit (included) and a cordless screwdriver until the seal is pressed against the plaster.
Note: The thermal separation module drills itself through the insulation (additional sealing is not necessary, unless the plaster is very rough)

9. Observe curing time of the injection system, see cartridge label of the ResiFIX injection mortar.
10. Afterwards, the attachment can be mounted, max. torque $T_{inst} = 25 \text{ Nm}$ (ResiTHERM® 16) or 19 Nm (ResiTHERM® 12)
(Observe possible deviating max. installation torque in the ETA of the injection system used)

ResiTHERM 16® Sets

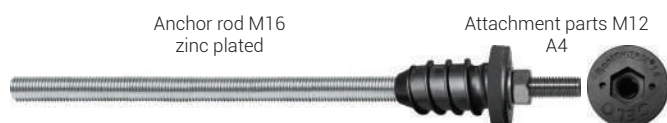

ResiTHERM® 8.8 16/250 M12

Type	Art-No	Content Set [preassembled]	Length L [mm]	Con- nection thread	Thickness of insula- tion e [mm]		€ / set	 [set]	 [sets]
Set ResiTHERM® 8.8 16/250 M12, 2 pieces	9250RTH162	2x ResiTHERM® 16, thermal separation module M16 / M12 2x Threaded rod M16x350, DIN 976, zinc plated, steel quality 8.8 2x Threaded stud M12x70, DIN 913, A4 2x Hexagon nut M12, DIN 934, A4 2x Washer M12, DIN 125, A4 1x Hexagon socket bit, size 6 1x Mixing nozzle extension 245 mm 2x Plastic sleeve SH 20x130 mm 1x Instruction manual ResiTHERM® 16	385	M12	Concrete: 60- 300 Solid brick, Aerated concrete: 60 - 280 Hollow brick: 60 - 250			1	8
Set ResiTHERM® 8.8 16/250 M12, 20 pieces	9250RTH1620	20x ResiTHERM® 16, thermal separation module M16 / M12 20x Threaded rod M16x350, DIN 976, zinc plated, steel quality 8.8 20x Threaded stud M12x70, DIN 913, A4 20x Hexagon nut M12, DIN 934, A4 20x Washer M12, DIN 125, A4 1x Hexagon socket bit, size 6 8x Mixing nozzle extension 245 mm 20x Plastic sleeve SH 20x130 mm 4x Instruction manual ResiTHERM® 16	385	M12	Concrete: 60- 300 Solid brick, Aerated concrete: 60 - 280 Hollow brick: 60 - 250			1	-



A4
STAINLESS
STEEL

ResiTHERM® A4 16/250 M12

Type	Art-No	Content Set [preassembled]	Length L [mm]	Con- nection thread	Thickness of insula- tion e [mm]		€ / set	 [set]	 [sets]
Set ResiTHERM® A4 16/250 M12, 2 pieces	9X250RTH162	2x ResiTHERM® 16, thermal separation module M16 / M12 2x Threaded rod M16x350, DIN 976, stainless steel A4 2x Threaded stud M12x70, DIN 913, A4 2x Hexagon nut M12, DIN 934, A4 2x Washer M12, DIN 125, A4 1x Hexagon socket bit, size 6 1x Mixing nozzle extension 245 mm 2x Plastic sleeve SH 20x130 mm 1x Instruction manual ResiTHERM® 16	385	M12	Concrete: 60- 300 Solid brick, Aerated concrete: 60 - 280 Hollow brick: 60 - 250			1	8
Set ResiTHERM® A4 16/250 M12, 20 pieces	9X250RTH1620	20x ResiTHERM® 16, thermal separation module M16 / M12 20x Threaded rod M16x350, DIN 976, stainless steel A4 20x Threaded stud M12x70, DIN 913, A4 20x Hexagon nut M12, DIN 934, A4 20x Washer M12, DIN 125, A4 1x Hexagon socket bit, size 6 8x Mixing nozzle extension 245 mm 20x Plastic sleeve SH 20x130 mm 4x Instruction manual ResiTHERM® 16	385	M12	Concrete: 60- 300 Solid brick, Aerated concrete: 60 - 280 Hollow brick: 60 - 250			1	-

ResiTHERM 12® Sets



ResiTHERM® 8.8 12/160 M12

Type	Art-No	Content Set (preassembled)	Length L [mm]	Con-nection thread	Thickness of insula-tion e [mm]		€/ set		
Set ResiTHERM® 8.8 12/160 M12, 2 pieces	9160RTH122	2x ResiTHERM® 12, thermal separation module M12 / M12 2x Threaded rod M12x260, DIN 976, zinc plated, steel quality 8.8 2x Threaded stud M12x70, DIN 913, A4 2x Hexagon nut M12, DIN 934, A4 2x Washer M12, DIN 125, A4 1x Hexagon socket bit, size 6 1x Mixing nozzle extension 245 mm 2x Plastic sleeve SH 20x130 mm 1x Instruction manual ResiTHERM® 12	295	M12	Concrete: 60 - 220 Solid brick, Aerated concrete: 60 - 190 Hollow brick: 60 - 160			1	8
Set ResiTHERM® 8.8 12/160 M12, 20 pieces	9160RTH1220	20x ResiTHERM® 12, thermal separation module M12 / M12 20x Threaded rod M12x260, DIN 976, zinc plated, steel quality 8.8 20x Threaded stud M12x70, DIN 913, A4 20x Hexagon nut M12, DIN 934, A4 20x Washer M12, DIN 125, A4 1x Hexagon socket bit, size 6 8x Mixing nozzle extension 245 mm 20x Plastic sleeve SH 20x130 mm 4x Instruction manual ResiTHERM® 12	295	M12	Concrete: 60 - 220 Solid brick, Aerated concrete: 60 - 190 Hollow brick: 60 - 160			1	-



ResiTHERM® A4 12/160 M12

Type	Art-No	Content Set (preassembled)	Length L [mm]	Con-nection thread	Thickness of insula-tion e [mm]		€/ set		
Set ResiTHERM® A4 12/160 M12, 2 pieces	9X160RTH122	2x ResiTHERM® 12, thermal separation module M12 / M12 2x Threaded rod M12x260, DIN 976, stainless steel A4 2x Threaded stud M12x70, DIN 913, A4 2x Hexagon nut M12, DIN 934, A4 2x Washer M12, DIN 125, A4 1x Hexagon socket bit, size 6 1x Mixing nozzle extension 245 mm 2x Plastic sleeve SH 20x130 mm 1x Instruction manual ResiTHERM® 12	295	M12	Concrete: 60 - 220 Solid brick, Aerated concrete: 60 - 190 Hollow brick: 60 - 160			1	8
Set ResiTHERM® A4 12/160 M12, 20 pieces	9X160RTH1220	20x ResiTHERM® 12, thermal separation module M12 / M12 20x Threaded rod M12x260, DIN 976, stainless steel A4 20x Threaded stud M12x70, DIN 913, A4 20x Hexagon nut M12, DIN 934 A4 20x Washer M12, DIN 125, A4 1x Hexagon socket bit, size 6 8x Mixing nozzle extension 245 mm 20x Plastic sleeve SH 20x130 mm 4x Instruction manual ResiTHERM® 12	295	M12	Concrete: 60 - 220 Solid brick, Aerated concrete: 60 - 190 Hollow brick: 60 - 160			1	-

ResiTHERM® 16 & 12 accessories



Two-hole nut driver DIN 3116C for adjusting ResiTHERM® 16 & 12

Type	Art-No	Length L [mm]	Width B [mm]	Sheet thickness t _m [mm]	Suitable for	€ / pc	[pcs]	[pcs]
Twohole nut driver	155253AMT	155	25	3	ResiTHERM® 16 & 12		1	15



Threaded stud adapter M12/M10, stainless steel A4 incl M10 nut and washer



Type	Art-No	Length L [mm]	Suitable for	€ / pc	[pcs]	[pcs]
Threaded stud adapter	X70M12M10ECT4	70	ResiTHERM® 16 & 12		4	60



Vinylester VYSF (styrene free)

Type	Art-No	Content [ml]	Mixing nozzles included [pcs]	Shelf life [months]	ETA	€ / pc	[pcs]
VY 300 SF	300VSF	280	2	18	●		12
VY 345 SF	345VSF	345	2	18	●		12
VY 410 SF	410VYSF	410	1	18	●		12



Vinylester VY ECO SF (styrene free)

Type	Art-No	Content [ml]	Mixing nozzles included [pcs]	Shelf life [months]	ETA	€ / pc	[pcs]
VY ECO 300 SF	300VYECOSF	300	2	18	●		12



Polyester PYSF (styrene free)

Type	Art-No	Content [ml]	Mixing nozzles included [pcs]	Shelf life [months]	ETA	€ / pc	[pcs]
PY 165 SF	165PSF	165	2	18	●		1/12
PY 300 SF	300PSF	300	1	18	●		12
PY 345 SF	345PSF	345	1	18	●		12
PY 410 SF	410PYSF	410	1	18	●		12



Type	Art-No	Length [mm]	Suitable for drill hole Ø [mm]	Suitable for anchor rod	Connecting thread	€ / pc	[pcs]
RBS Ø20 for concrete and masonry	9M20RBK	200	18	M16	M6		5
Extension for RBS Ø20	MRBKV	–	all	all	M6		5
Handle for RBS Ø20	MRBKH	140	all	all	M6		5
RBK Ø20 for masonry*	9PLRBK	300	20	M16	–		5
Blow out pump AB	BOP	300	8	–	–		1

*) not part of the ETA assessments of the ResiFIX injection mortars



Type	Art-No	Outer-Ø [mm]	Length [mm]	€ / pc	[pcs]
MD	9MRMEA	–	215		10
MDV 10	9MDV	10	200		10
MDV 10	9500MDV	10	500		10



Type	Art-No	suitable for ResiFIX type	€ / pc	[pcs]
APP 300	300APP	300 / 165 / 280		1
APVM	345APVM	345 / 300 / 280 / 165		1
APP 380	380APP	410		1

ResiTHERM® 16 & 12 technical data

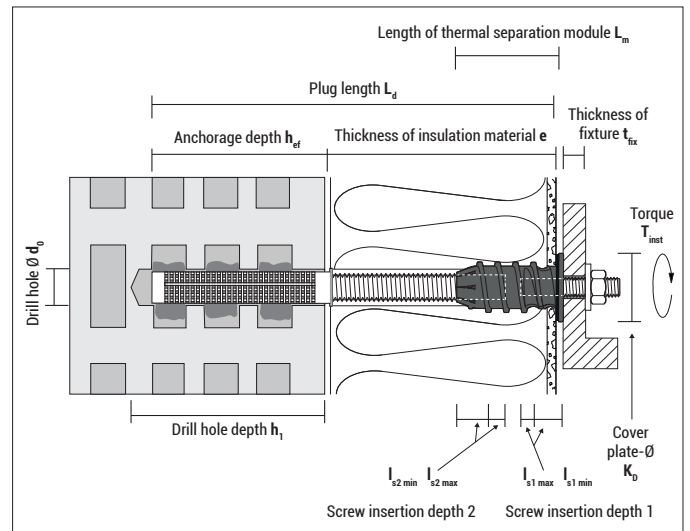
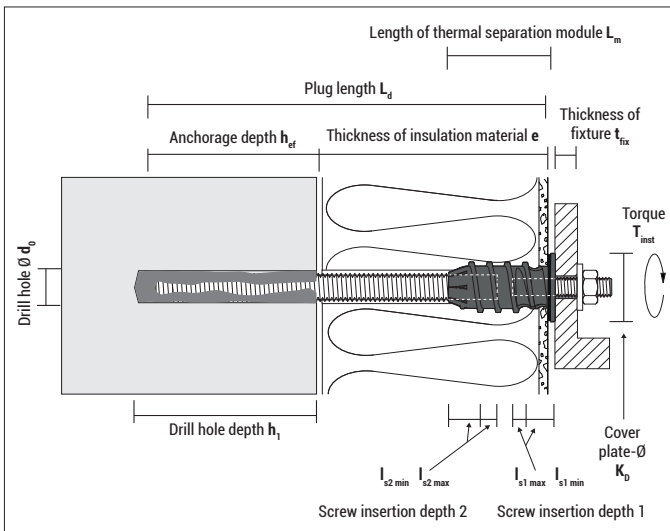
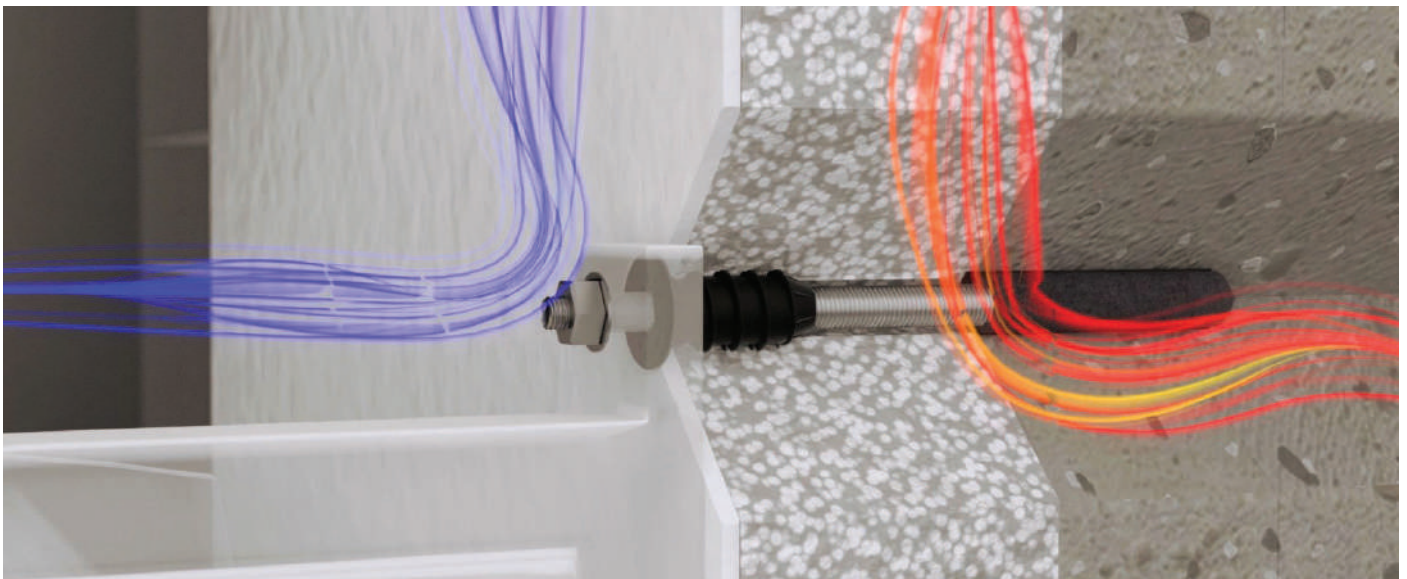

Installation parameters	Installation in concrete		Installation in aerated concrete/solid brick		Installation in perforated brick			
	ResiTHERM® 16	ResiTHERM® 12	ResiTHERM® 16	ResiTHERM® 12	ResiTHERM® 16	ResiTHERM® 12		
Plug length	L_d	[mm]	385 ¹⁾	295 ¹⁾	385 ¹⁾	295 ¹⁾	385 ¹⁾	295 ¹⁾
Thickness of insulation material (incl. plaster)	e	[mm]	60 - max. 300	60 - max. 220	60 - max. 280	60 - max. 190	60 - max. 250	60 - max. 160
Length of thermal separation module (to lower edge of cover plate)	L_m	[mm]	60	60	60	60	60	60
Diameter cover plate	K_D	[mm]	42	42	42	42	42	42
Threaded rod		[mm]	M16 x 350 ¹⁾	M12 x 260 ¹⁾	M16 x 350 ¹⁾	M12 x 260 ¹⁾	M16 x 350 ¹⁾	M12 x 260 ¹⁾
Insertion depth of threaded stud	$l_{s2 \text{ min-max}}$	[mm]	24-27	24-27	24-27	24-27	24-27	24-27
Drill hole diameter	d_0	[mm]	18	14	18	14	20	20
Drill hole depth	$h_1 \geq$	[mm]	90 + e	80 + e	110 + e	110 + e	140 + e	140 + e
Anchorage depth	h_{ef}	[mm]	80	70	100	100	125	125
Plastic sleeve SH			-	-	-	-	20-130	20-130
Connecting thread		[mm]	M12 ³⁾	M12 ³⁾	M12 ³⁾	M12 ³⁾	M12 ³⁾	M12 ³⁾
Insertion depth of M12 threaded stud	$l_{s1 \text{ min-max}}$	[mm]	30-34	30-34	30-34	30-34	30-34	30-34
Thickness of fixture	$t_{fix} \leq$	[mm]	24 ²⁾	24 ²⁾	24 ²⁾	24 ²⁾	24 ²⁾	24 ²⁾







¹⁾ Threaded rod has to be cut as needed.

For further technical values, see assessment of the ResiFIX injection system used.

²⁾ When using the threaded stud with length $L=70$ mm. Otherwise, a longer threaded stud or a longer metric screw can be used.

³⁾ Alternative: Threaded stud adapter M12/M10, length 70 mm, stainless steel A4, Art-No X70M12M10ECT4

Permissible tension load and pressure load ResiTHERM® 16¹⁾ at 24°C/40°C²⁾

M16 anchor rod in 8.8	applied injection mortar ResiFIX VY SF acc. ETA-10/0134		applied injection mortar ResiFIX VY SF acc. ETA-15/0320			
Base material						
	Concrete C20/25 ³⁾	Solid sand-lime brick KS KS28-2,0 ³⁾	Solid brick MZ 20-2,0 ¹⁾	Hollow sand-lime brick KSL 12-1,4 ⁴⁾	Hollow brick HLZ 12-1,25 ⁴⁾	Aerated concrete AAC 2 ³⁾
Insulation thickness e	Permissible tension load N_{per}					
	[kN]	[kN]	[kN]	[kN]	[kN]	[kN]
60-300 mm	4,57	2,00	2,29	1,65	1,11	0,71
Insulation thickness e	Permissible pressure load P_{per}					
	[kN]	[kN]	[kN]	[kN]	[kN]	[kN]
60 - 220 mm	5,14	2,00	2,29	1,65	1,11	0,71
221 - 300 mm	5,14	2,00	2,29	1,65	1,11	0,71
Min. anchorage depth h_{ef}	80	100	100	130	130	100







¹⁾ Loads include the partial safety factors of the material given in the ETA as well as a partial safety factor for the actions of $\gamma_F = 1.4$.

²⁾ For other temperature ranges see ETA-assessment.

³⁾ In full material the tension load resistance can be used also for the pressure load resistance.

⁴⁾ In hollow materials the pressure load resistance specified in the ETA can be applied, if the setting depth is deep enough to include minimum 5 webs with the injection mortar. If the setting depth is lower and does not include 5 webs, then the pressure load resistance must be reduced.

Permissible tension load and pressure load ResiTHERM® 12¹⁾ at 24°C/40°C²⁾

M12 anchor rod in 8.8	applied injection mortar ResiFIX VY SF acc. ETA-10/0134		applied injection mortar ResiFIX VY SF acc. ETA-15/0320			
Base material						
	Concrete C20/25 ³⁾	Solid sand-lime brick KS KS28-2,0 ³⁾	Solid brick MZ 20-2,0 ¹⁾	Hollow sand-lime brick KSL 12-1,4 ⁴⁾	Hollow brick HLZ 12-1,25 ⁴⁾	Aerated concrete AAC 2 ³⁾
Insulation thickness e	Permissible tension load N_{per}					
	[kN]	[kN]	[kN]	[kN]	[kN]	[kN]
60 - 220 mm	5,14	2,00	2,00	1,65	1,11	0,71
Insulation thickness e	Permissible pressure load P_{per}					
	[kN]	[kN]	[kN]	[kN]	[kN]	[kN]
60 - 120 mm	5,14	2,00	2,00	1,65	1,11	0,71
121 - 160 mm	5,14	2,00	2,00	1,65	1,11	0,71
161 - 220 mm	2,86	2,00	2,00	1,65	1,11	0,71
Min. anchorage depth h_{ef}	70	100	100	130	130	100

¹⁾ Loads include the partial safety factors of the material given in the ETA as well as a partial safety factor for the actions of $\gamma_F = 1.4$.





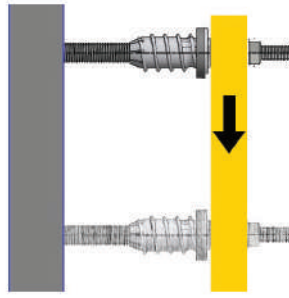

²⁾ For other temperature ranges see ETA-assessment.

³⁾ In full material the tension load resistance can be used also for the pressure load resistance.

⁴⁾ In hollow materials the pressure load resistance specified in the ETA can be applied, if the setting depth is deep enough to include minimum 5 webs with the injection mortar. If the setting depth is lower and does not include 5 webs, then the pressure load resistance must be reduced.



Maximum shear loads $V^{1)}$ of a single plug at max. 3 or 5 mm displacement per ResiTHERM[®] if the free outer end of the ResiTHERM[®] 16 & 12 is not freely rotatable [e.g. connected double fixing]²⁾ at 24°C/40°C³⁾

Not free rotatable anchor rod M16 in 8.8	applied injection mortar ResiFIX VY SF acc. ETA-10/0134	applied injection mortar ResiFIX VY SF acc. ETA-15/0320					
	 Concrete C20/25  Solid sand-lime brick KS KS28-2,0  Solid brick MZ 20-2,0  Hollow sand-lime brick KSL 12-1,4  Hollow brick HLZ 12-1,25  Aerated concrete AAC 2						

if displacement is 3 mm

Insulation thickness e [mm]	Maximum shear load V [kN]											
	ResiTHERM [®] 16		ResiTHERM [®] 12		ResiTHERM [®] 16		ResiTHERM [®] 12		ResiTHERM [®] 16		ResiTHERM [®] 12	
	16	12	16	12	16	12	16	12	16	12	16	12
60	2,14	1,43	2,00	1,43	2,14	1,43	1,53	1,43	2,14	1,43	0,89	0,89
80	2,14	1,43	2,00	1,43	2,14	1,43	1,53	1,43	2,14	1,43	0,89	0,89
100	2,14	1,43	2,00	1,43	2,14	1,43	1,53	1,43	2,14	1,43	0,89	0,89
120	1,84	1,01	1,84	1,01	1,84	1,01	1,53	1,01	1,84	1,01	0,89	0,89
140	1,49	0,85	1,49	0,85	1,49	0,85	1,49	0,85	1,49	0,85	0,89	0,85
160	1,15	0,69	1,15	0,69	1,15	0,69	1,15	0,69	1,15	0,69	0,89	0,69
180	0,80	0,54	0,80	0,54	0,80	0,54	0,80	0,54	0,80	0,54	0,80	0,54
200	0,71	0,38	0,71	0,38	0,71	0,38	0,71	0,38	0,71	0,38	0,71	0,38
220	0,61	0,22	0,61	0,22	0,61	0,22	0,61	0,22	0,61	0,22	0,61	0,22
240	0,51	-	0,51	-	0,51	-	0,51	-	0,51	-	0,51	-
250	0,47	-	0,47	-	0,47	-	0,47	-	0,47	-	0,47	-
260	0,42	-	0,42	-	0,42	-	0,42	-	0,42	-	0,42	-
280	0,32	-	0,32	-	0,32	-	0,32	-	0,32	-	0,32	-
300	0,22	-	0,22	-	0,22	-	0,22	-	0,22	-	0,22	-

if displacement is 5 mm

Insulation thickness e [mm]	Maximum shear load V [kN]											
	ResiTHERM [®] 16		ResiTHERM [®] 12		ResiTHERM [®] 16		ResiTHERM [®] 12		ResiTHERM [®] 16		ResiTHERM [®] 12	
	16	12	16	12	16	12	16	12	16	12	16	12
60	2,14	1,43	2,00	1,43	2,14	1,43	1,53	1,43	2,14	1,43	0,89	0,89
80	2,14	1,43	2,00	1,43	2,14	1,43	1,53	1,43	2,14	1,43	0,89	0,89
100	2,14	1,43	2,00	1,43	2,14	1,43	1,53	1,43	2,14	1,43	0,89	0,89
120	2,14	1,43	2,00	1,43	2,14	1,43	1,53	1,43	2,14	1,43	0,89	0,89
140	2,14	1,29	2,00	1,29	2,14	1,29	1,53	1,29	2,14	1,29	0,89	0,89
160	1,76	1,06	1,76	1,06	1,76	1,06	1,53	1,06	1,76	1,06	0,89	0,89
180	1,27	0,82	1,27	0,82	1,27	0,82	1,27	0,82	1,27	0,82	0,89	0,82
200	1,12	0,59	1,12	0,59	1,12	0,59	1,12	0,59	1,12	0,59	0,89	0,59
220	0,97	0,35	0,97	0,35	0,97	0,35	0,97	0,35	0,97	0,35	0,89	0,35
240	0,82	-	0,82	-	0,82	-	0,82	-	0,82	-	0,82	-
250	0,74	-	0,74	-	0,74	-	0,74	-	0,74	-	0,74	-
260	0,67	-	0,67	-	0,67	-	0,67	-	0,67	-	0,67	-
280	0,51	-	0,51	-	0,51	-	0,51	-	0,51	-	0,51	-
300	0,36	-	0,36	-	0,36	-	0,36	-	0,36	-	0,36	-

Thickness of structural part h_{min} [mm]	112	115	115	195	195	240
Min. edge distance c_{min} [mm]	80	60	60	60	50	50
Min. spacing s_{min} [mm]	80	75	65	120	50	50
Torque T_{inst} [Nm]	25 ⁴⁾	19 ⁴⁾	15 ⁴⁾	10 ⁴⁾	8 ⁴⁾	10 ⁴⁾

All values are based on injection mortar ResiFIX VY SF, see page 182

¹⁾ Intermediate values can be interpolated/ Values are limited due to the maximum shear load capacity.

²⁾ e.g. for awning brackets or supported canopies

³⁾ For other temperature ranges see ETA-assessment.

⁴⁾ Depending on the base material, see ETA of ResiFIX injection mortar

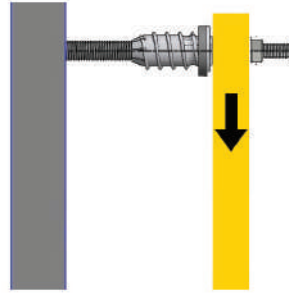

Maximum shear loads V ¹⁾ of a single plug at max. 3 or 5 mm displacement per ResiTHERM® if the free outer end of the ResiTHERM® 16 & 12 is freely rotatable²⁾ at 24°C/40°C³⁾

Free rotatable anchor rod M16 in 8.8	applied injection mortar ResiFIX VY SF acc. ETA-10/0134	applied injection mortar ResiFIX VY SF acc. ETA-15/0320					
Base material							

if displacement is 3 mm

Insulation thickness e [mm]	Maximum shear load V [kN]											
	ResiTHERM® 16		ResiTHERM® 12		ResiTHERM® 16		ResiTHERM® 12		ResiTHERM® 16		ResiTHERM® 12	
60	1,59	1,25	1,59	1,25	1,59	1,25	1,53	1,25	1,59	1,25	0,89	0,89
80	1,38	0,85	1,38	0,85	1,38	0,85	1,38	0,85	1,38	0,85	0,89	0,85
100	1,06	0,61	1,06	0,61	1,06	0,61	1,06	0,61	1,06	0,61	0,89	0,61
120	0,75	0,36	0,75	0,36	0,75	0,36	0,75	0,36	0,75	0,36	0,75	0,36
140	0,63	0,31	0,63	0,31	0,63	0,31	0,63	0,31	0,63	0,31	0,63	0,31
160	0,52	0,25	0,52	0,25	0,52	0,25	0,52	0,25	0,52	0,25	0,52	0,25
180	0,41	0,20	0,41	0,20	0,41	0,20	0,41	0,20	0,41	0,20	0,41	0,20
200	0,36	0,14	0,36	0,14	0,36	0,14	0,36	0,14	0,36	0,14	0,36	0,14
220	0,31	0,09	0,31	0,09	0,31	0,09	0,31	0,09	0,31	0,09	0,31	0,09
240	0,26	–	0,26	–	0,26	–	0,26	–	0,26	–	0,26	–
250	0,24	–	0,24	–	0,24	–	0,24	–	0,24	–	0,24	–
260	0,21	–	0,21	–	0,21	–	0,21	–	0,21	–	0,21	–
280	0,17	–	0,17	–	0,17	–	0,17	–	0,17	–	0,17	–
300	0,12	–	0,12	–	0,12	–	0,12	–	0,12	–	0,12	–

if displacement is 5 mm

Insulation thickness e [mm]	Maximum shear load V [kN]											
	ResiTHERM® 16		ResiTHERM® 12		ResiTHERM® 16		ResiTHERM® 12		ResiTHERM® 16		ResiTHERM® 12	
60	1,86	1,43	1,86	1,43	1,86	1,43	1,53	1,43	1,86	1,43	0,89	0,89
80	1,86	1,35	1,86	1,35	1,86	1,35	1,53	1,35	1,86	1,35	0,89	0,89
100	1,66	0,96	1,66	0,96	1,66	0,96	1,53	0,96	1,66	0,96	0,89	0,89
120	1,19	0,56	1,19	0,56	1,19	0,56	1,19	0,56	1,19	0,56	0,89	0,56
140	1,00	0,48	1,00	0,48	1,00	0,48	1,00	0,48	1,00	0,48	0,89	0,48
160	0,82	0,40	0,82	0,40	0,82	0,40	0,82	0,40	0,82	0,40	0,82	0,40
180	0,64	0,31	0,64	0,31	0,64	0,31	0,64	0,31	0,64	0,31	0,64	0,31
200	0,56	0,23	0,56	0,23	0,56	0,23	0,56	0,23	0,56	0,23	0,56	0,23
220	0,49	0,15	0,49	0,15	0,49	0,15	0,49	0,15	0,49	0,15	0,49	0,15
240	0,42	–	0,42	–	0,42	–	0,42	–	0,42	–	0,42	–
250	0,38	–	0,38	–	0,38	–	0,38	–	0,38	–	0,38	–
260	0,34	–	0,34	–	0,34	–	0,34	–	0,34	–	0,34	–
280	0,27	–	0,27	–	0,27	–	0,27	–	0,27	–	0,27	–
300	0,19	–	0,19	–	0,19	–	0,19	–	0,19	–	0,19	–

Thickness of structural part	h_{min} [mm]	112	115	115	195	195	240
Min. edge distance	c_{min} [mm]	80	60	60	60	50	50
Min. spacing	s_{min} [mm]	80	75	65	120	50	50
Torque	T_{inst} [Nm]	25 ⁴⁾	19 ⁴⁾	15 ⁴⁾	10 ⁴⁾	8 ⁴⁾	10 ⁴⁾

All values are based on injection mortar ResiFIX VY SF, see page 182

¹⁾ Intermediate values can be interpolated/ Values are limited due to the maximum shear load capacity.

²⁾ e.g. several ResiTHERM® in a row with a freely cantilevered glass canopy

³⁾ For other temperature ranges see ETA-assessment.

⁴⁾ Depending on the base material, see ETA of ResiFIX injection mortar

Distance mounting system ResiTHERM® 37

Advantages



ResiTHERM® 37/200 M12



ResiTHERM® 37/160 M12



ResiTHERM® 37/120 M12

- The perfect solution for distance installations in hollow bricks with ETA approval
- Heavy-duty system for fastening of awnings, canopies, french balconies, railings, satellite dishes etc. in ETICS
- Excellent thermal separation, almost no thermal bridge
- Outstanding high values in hollow bricks
- Easy and fast installation saves time and money
- Product is ready to use: available in three standard lengths
- Suitable for insulation thicknesses up to 200 mm
- For non-insulated hollow brick walls:
ResiTHERM® 37S M12 (p. 119)
- ResiTHERM® 37 was tested together with the injection system ResiFIX VYSF



Approvals and certificates



Mounting

Suitable building materials

Very suitable

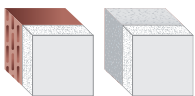

- Hollow brick
- Aerated concrete



Suitable to a limited extent



- Hollow sand-lime brick
- Solid brick
- Solid sand-lime brick
- Concrete

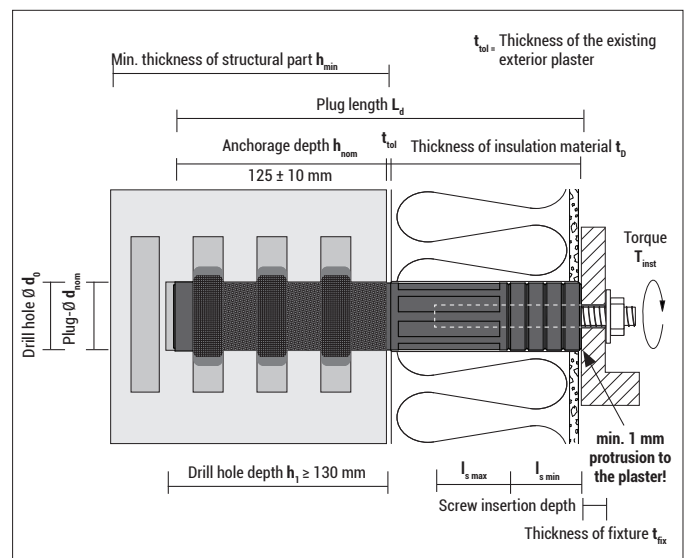

Distance mounting system ResiTHERM® 37

Mounting in hollow brick

1. Put drilling aid on core bit; drill with cordless screwdriver (without impact) through the insulation material up to the hollow brick wall (remove drilling aid after the first 10 mm)
2. Measure the thickness of the insulation and cut ResiTHERM® 37 if needed (max. 40 mm)
3. Put drilling aid on core bit and drill min. 130 mm into the hollow brick wall (remove drilling aid after the first 10 mm)
4. Clean hole
5. Press ResiTHERM® 37 onto mixing nozzle and push it carefully into the drill hole
6. Fill ResiTHERM® 37 with injection system ResiFIX; the end of the filling process can be clearly felt
7. Respect curing time
8. Fill annular gap with sealant StickFX XP, MS Polymer
9. Install fixture $T_{inst} \leq 20 \text{ Nm}$

Isothermic profile

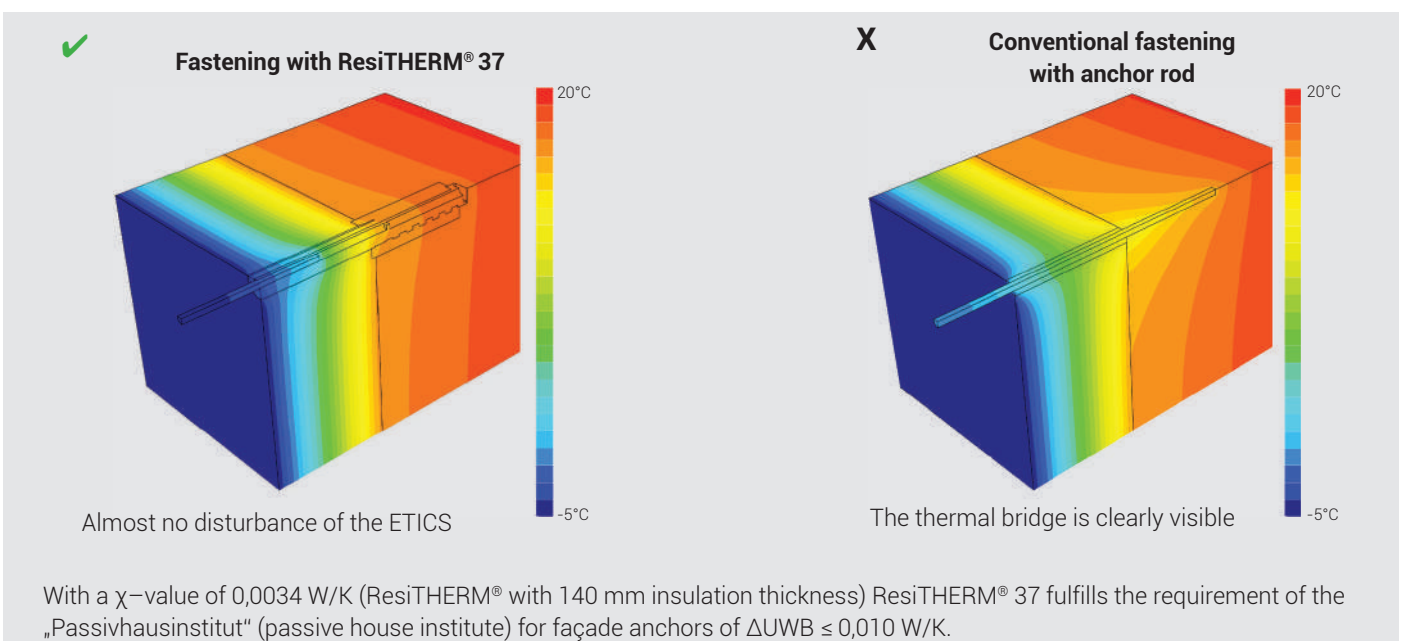

Distance mounting system ResiTHERM® 37



ResiTHERM® 37/200 M12 for insulation thicknesses 160 - 200 mm

Type	Art-No	Set contains (packed in bag)	L [mm]	Thickness of insulation material $h_d^{1)}$ [mm]		€ / Set	[Set]	[Sets]
RTH 200	200RTH2	2x ResiTHERM® 37/200 M12 2x Threaded stud M12x70 mm, stainless steel A4 2x Washer M12 DIN 125, stainless steel A4 2x Hexagon nut M12 DIN 934, stainless steel A4 1x ResiFIX VY300SF incl. 2 mixing nozzles MD	325	160 - 200	●		1	10

¹⁾ ResiTHERM® 37 may be cut up to 40 mm if needed.

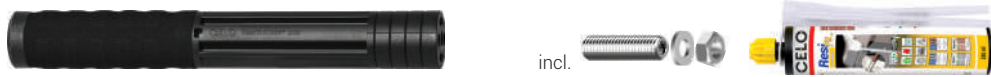

ResiTHERM® 37/160 M12 for insulation thicknesses 120 - 160 mm

Type	Art-No	Set contains (packed in bag)	L [mm]	Thickness of insulation material $h_d^{1)}$ [mm]		€ / Set	[Set]	[Sets]
RTH 160	160RTH2	2x ResiTHERM® 37/160 M12 2x Threaded stud M12x70 mm, stainless steel A4 2x Washer M12 DIN 125, stainless steel A4 2x Hexagon nut M12 DIN 934, stainless steel A4 1x ResiFIX VY300SF incl. 2 mixing nozzles MD	285	120 - 160	●		1	10

¹⁾ ResiTHERM® 37 may be cut up to 40 mm if needed.



ResiTHERM® 37/120 M12 for insulation thicknesses 80 - 120 mm

Type	Art-No	Set contains (packed in bag)	L [mm]	Thickness of insulation material $h_d^{1)}$ [mm]		€ / Set	[Set]	[Sets]
RTH 120	120RTH2	2x ResiTHERM® 37/120 M12 2x Threaded stud M12x70 mm, stainless steel A4 2x Washer M12 DIN 125, stainless steel A4 2x Hexagon nut M12 DIN 934, stainless steel A4 1x ResiFIX VY300SF incl. 2 mixing nozzles MD	245	80 - 120	●		1	10

¹⁾ ResiTHERM® may be cut up to 40 mm if needed.

Heavy-duty sleeve ResiTHERM® 37S

Advantages



- The perfect solution for heavy-duty applications in hollow / perforated brick walls (not insulated) with ETA approval
- Heavy-duty system for fastening of awnings, canopies, french balconies, railings, satellite dishes etc.
- Outstanding high values also in thin-walled perforated bricks
- Excellent thermal separation, almost no thermal bridge
- For insulated hollow brick walls use **ResiTHERM® 37** (p. 116)
- ResiTHERM® 37S was tested together with the injection system ResiFIX VYSF



Approvals and certificates



European Technical Assessment
Distance mounting system
for masonry



Suitable building materials

Very suitable



- Hollow brick
- Aerated concrete

Suitable to a limited extent



- Hollow sand-lime brick
- Solid sand-lime brick
- Solid brick
- Concrete

Mounting

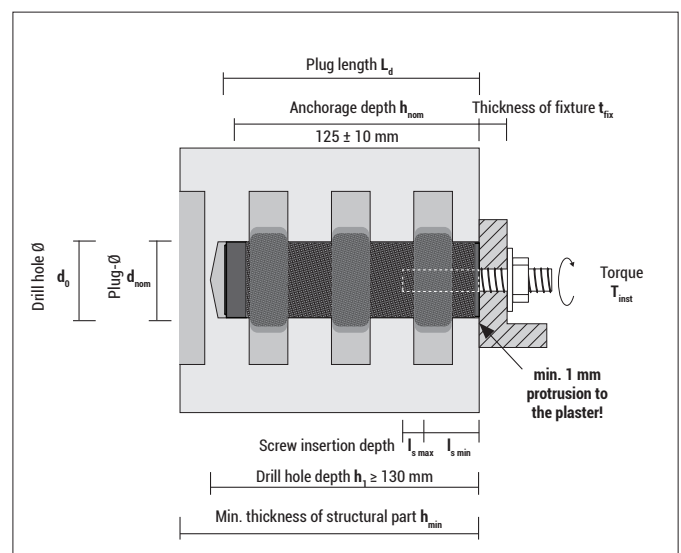

Heavy-duty sleeve ResiTHERM® 37S

Mounting in hollow brick

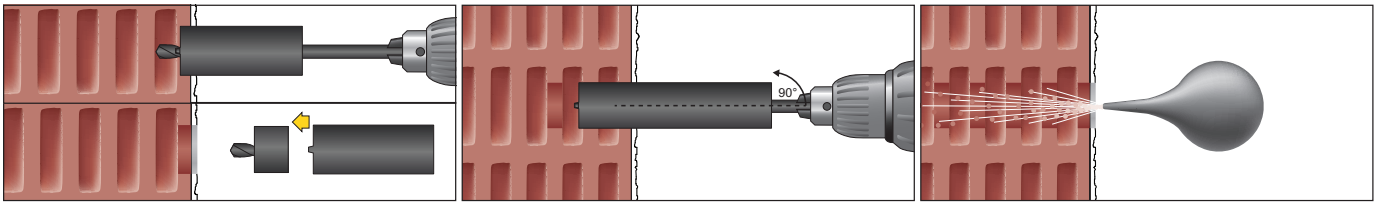

1. Put drilling aid on core bit; drill with cordless screwdriver (without impact) into the hollow brick wall; remove drilling aid after the first 10 mm)

2. Drill hole (without impact); drill hole depth min. 130 mm

3. Clean hole

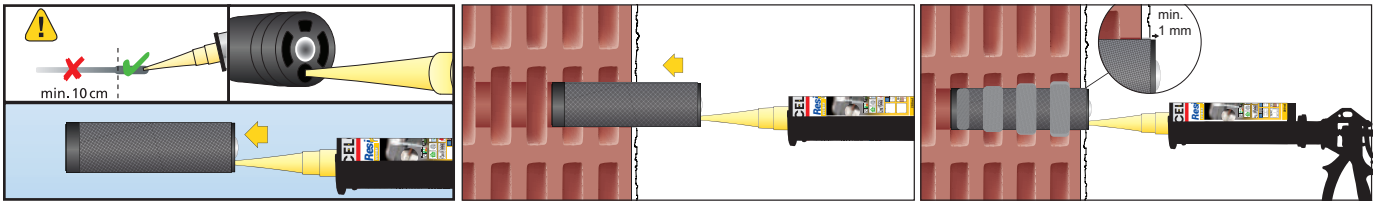

4. Press ResiTHERM® 37S onto the mixing nozzle

5. Push ResiTHERM® 37S carefully into the drill hole

6. Fill ResiTHERM® 37S with injection system ResiFIX; the end of the filling process can be clearly felt

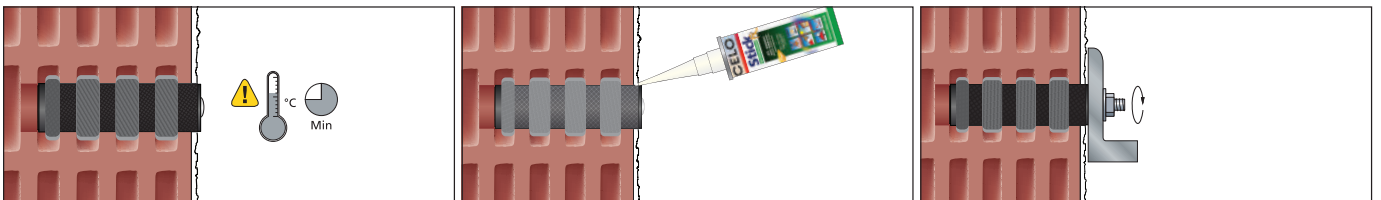



7. Respect curing time

8. Fill annular gap with sealant StickFX XP, MS Polymer

9. Install fixture $T_{inst} \leq 20 \text{ Nm}$



Heavy-duty sleeve ResiTHERM® 37S M12 for non-insulated hollow brick walls

Type	Art-No	Set contains (packed in bag)	L_d [mm]	Thickness of insulation material h_p [mm]		€/Set	 [Set]	 [Sets]
RTH S	RTHS2	2x ResiTHERM® 37S M12 2x Threaded stud M12x70 mm, stainless steel A4 2x Washer M12 DIN 125, stainless steel A4 2x Hexagon nut M12 DIN 934, stainless steel A4 1x ResiFIX VY300SF incl. 2 mixing nozzles MD	125	0	●		1	10

ResiTHERM® 37 Accessories

Core bit for perforated brick BST

Drilling aid for core bit ABH



Core bit BST and drilling aid ABH for core bit for ResiTHERM®

Type	Art-No	d [mm]	L [mm]	Connecting thread	€/pc	[pcs]	[pcs]
BST 39 x 220	39220BST	39	220	M16		1	-
ABH	39ABH	35	60	-		1	-

AD 100

AD 200



Adapter shank AD hexagon for core bit BST for ResiTHERM®

Type	Art-No	L [mm]	Connecting thread	Shank for drilling machine	Insulation thickness [mm]	€/pc	[pcs]	[pcs]
AD 100	100M16AD	100	M16	hexagon	≤ 160		1	-
AD 200	200M16AD	200	M16	hexagon	160 - 260		1	-



Vynylester VYSF (styrene free)

Type	Art-No	Content [ml]	Mixings nozzles included [pcs]	€/pc	[pcs]
VY 300 SF	300VSF	280	2		12

Curing times see page 178



StickFX Professional adhesive and sealant CL

Type	Art-No	Content [ml]	Colour	Description	€/pc	[pcs]
CL	TR290MSCL	290	transparent	Adhesive and sealant		12



Distance washer AS Polyamid, DIN 9021 for M12

Type	Art-No	Outer Ø [mm]	Disc hole Ø [mm]	Height H [mm]	€/100 pcs	[pcs]	[pcs]
AS	129021AS	37	13	3		50	-

To use as a distance washer for relining (if needed).



APVM

Manual dispenser APVM

Type	Art-No	Suitable for ResiFIX Type	€/100 pc	[pcs]
APVM	345APVM	345 / 300 / 280 / 165		1

Manual dispenser APVM is recommended to read the scale units of ResiFIX VY (outer rod serves as a pointer).



Blow out pump AB

Type	Art-No	Tube-Ø [mm]	€/pc	[pcs]	[pcs]
AB	BOP	8		1	-



ResiTHERM® 37 technical data



Installation parameters			ResiTHERM® 37S	ResiTHERM® 37/120	ResiTHERM® 37/160	ResiTHERM® 37/200
Anchor length	L_d	[mm]	125	245	285	325
Thickness of insulation material (incl. external plaster)	h_D	[mm]	0	60 ¹⁾ - 120	120 ¹⁾ - 160	160 ¹⁾ - 200
Anchor \emptyset	d_{nom}	[mm]	37			
Drill hole \emptyset	d_0	[mm]	39 - 40			
Drill hole depth	$h_1 \geq$	[mm]	130			
Anchorage depth	h_{nom}	[mm]	125 \pm 10 ²⁾			
Connecting thread		[mm]	M12			
Screw insertion depth of M12 threaded stud	$h_{s \text{ min-max}}$	[mm]	35 - 80			
Thickness of fixture	$t_{fix} \leq$	[mm]	22 ³⁾			
\emptyset of clearance hole in fixture	$d_f \geq$	[mm]	13			
Required volume of ResiFIX VY per ResiTHERM® 37		[ml]	ca. 140			
Installation torque for mounting the fixture	$T_{inst} \leq$	[Nm]	20			

¹⁾ ResiTHERM® 37 may be cut up to 40 mm if needed. ResiTHERM® 37/120 M12: If thickness of insulation material is 60 mm, set 20 mm deeper.

²⁾ Minimum anchorage depth of 115 mm is possible (see ETA assessment)

³⁾ When using a threaded stud with L=70 mm. Otherwise a longer threaded stud or a longer metric screw can be used.

Loads and displacements/deflections ResiTHERM®37: approved system with injection system ResiFIX VY SF

Building material	System	Thickness of insulation material [mm]	Recommended loads ¹⁾	Deflection at recommended load*
Permissible tension load			N_{per} [kN]	$\delta_{NO} / \delta_{N=}$ [mm]
Hollow brick T1.0x240 HLZ 12 (Format 12 DF)	Single fastening	all	1,71	0,60/ 1,30
Hollow brick T10x300 HLZ 6 (Format 10 DF)	Single fastening	all	0,86	0,60/ 1,20
Aerated concrete AAC2x0,35 ²⁾	Single fastening	all	1,21	0,14/ 0,28
Aerated concrete AAC4x0,55 ²⁾	Single fastening	all	2,12	0,32/ 0,64
Permissible pressure load			F_{per} [kN]	$\delta_{F0} / \delta_{F=}$ [mm]
Hollow brick T1.0x240 HLZ 12 (Format 12 DF)	Single fastening	all	1,71	0,60/ 1,30
Hollow brick T10x300 HLZ 6 (Format 10 DF)	Single fastening	all	0,86	0,60/ 1,20
Permissible shear load			V_{per} [kN]	$\delta_{V0} / \delta_{V=}$ [mm] ⁴⁾
Hollow brick T1.0x240 HLZ 12 (Format 12 DF)	Single fastening	0	0,86	0,20/ 0,30
		120	0,34	2,00/ 4,10
		160	0,34	2,10/ 4,30
	Double fastening ³⁾	0	0,51	0,60/ 1,20
		120	0,43	1,60/ 3,20
		160	0,34	0,70/ 1,40
Hollow brick T10x300 HLZ 6 (Format 10 DF)	Single fastening	0	0,43	0,00/ 0,10
		120	0,26	1,30/ 2,60
		160	0,26	1,70/ 2,50
	Double fastening ³⁾	0	0,17	2,00/ 4,00
		120	0,17	0,10/ 0,20
		160	0,11	0,20/ 0,30
		200	0,09	0,30/ 0,50

* Movement of ResiTHERM® 37 in load direction at permissible load.

¹⁾ Recommended loads include the partial safety factor on action of $\gamma_F = 1,4$.

²⁾ Not part of the ETA-assessment.

³⁾ Spacing of 77 mm (standard awning console).

⁴⁾ δ_{V0} = Initial deflection / $\delta_{V=}$ = long-term deflection

Spacing and edge distance

ResiTHERM® 37S, 37/120, 37/160, 37/200		HLZ 12	HLZ 6
Minimum spacing	S_{min} [mm]	77 ¹⁾	77 ¹⁾
Minimum edge distance	C_{min} [mm]	125	125
Minimum thickness of structural part	h_{min} [mm]	240	300

¹⁾ Spacing of 77 mm (standard awning console).

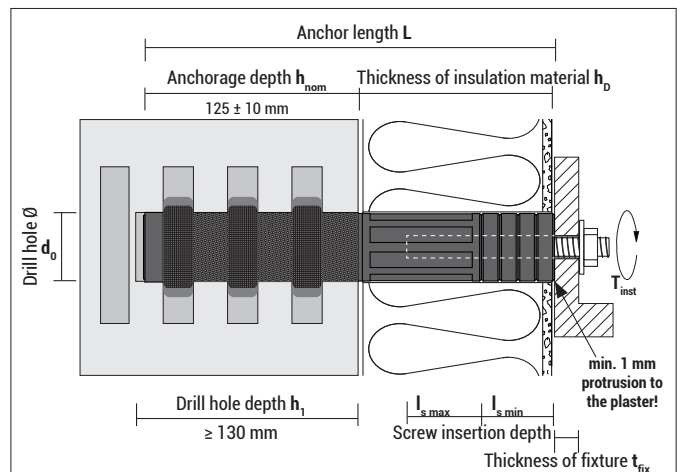

Sanitary Fixings

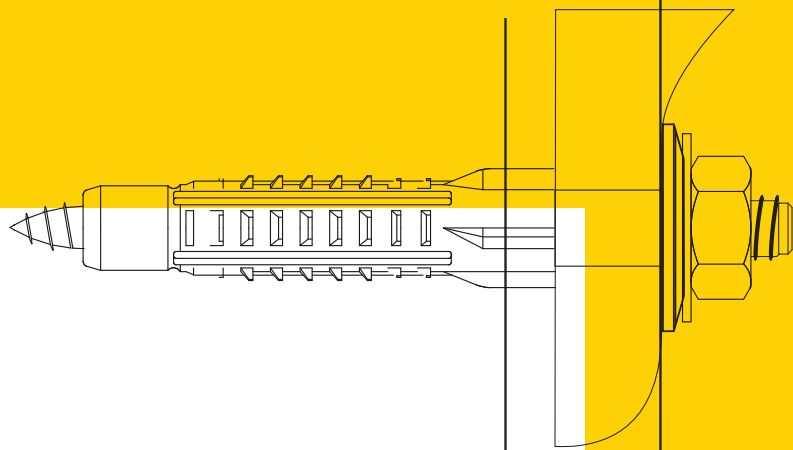

WC  124

FRH  126

WT  128

UB  129

Standing toilet installation set

WC



Advantages

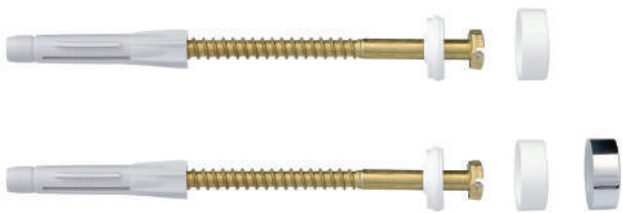

- Suitable for fastening of standing toilets
- Sets with universal plugs AZ can be used for nearly all building materials, see page 35
- Brass screws ensure corrosion resistance
- Plastic washers with collar protect the ceramic

Approvals and certificates



Suitable building materials

Very suitable



- | | |
|---|---|
| <ul style="list-style-type: none"> • Concrete • Natural stone • Solid brick • Solid sand-lime brick • Lightweight solid concrete blocks • Aerated concrete • Gypsum blocks | <ul style="list-style-type: none"> • Hollow brick • Hollow sand-lime brick • Lightweight hollow concrete blocks • Plasterboard/
Fibreboard • Chipboard |
|---|---|

Mounting

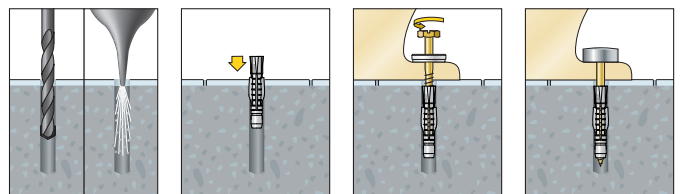

Standing toilet installation set WC

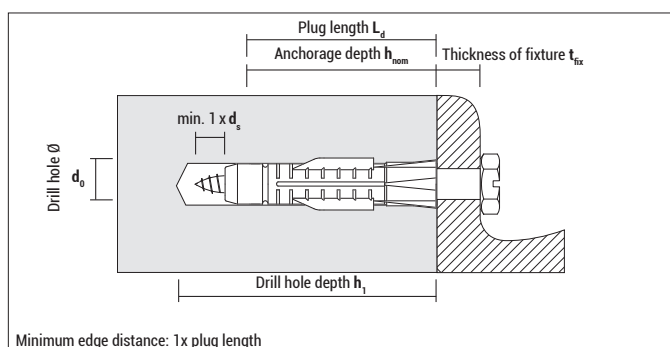

WC

Type	Art-No	Set contains	d_0 [mm]	$h_1 \geq$ [mm]	L_d [mm]	h_{nom} [mm]	$t_{fix} \leq$ [mm]	€/Set	[Sets]
white	91WC	2 plugs AZ 8 2 brass hex-head screws with slot 6 x 85 2 protection rings 2 cover caps white	8	60	50	50	30		50
white / chrome	9BFWC	2 plugs AZ 8 2 brass hex-head screws with slot 6 x 85 2 protection rings 2 cover caps white 2 cover caps chrome	8	60	50	50	30		50

Sets are packed in PVC bags



Blister WCS

Type	Art-No	d_0 [mm]	L_d [mm]	h_{nom} [mm]	d_s [mm]	L_s [mm]	Type of screw	€/Blister	[pcs]	[Blister]
WCS	5WCS2	8	50	50	6	85			2	10

Loads for wood screws F_{rec}

Type	Screw \varnothing d_s [mm]	Concrete F_{rec} [kN]	Hollow brick HLz 12 F_{rec} [kN]	Hollow brick Poroton T12 F_{rec} [kN]	Hollow brick KSL 12 F_{rec} [kN]	Solid brick KS 12 / Solid brick Mz 12 F_{rec} [kN]	Aerated concrete AAC2 F_{rec} [kN]	Plasterboard 12,5 mm F_{rec} [kN]	Plasterboard 2 x 12,5 mm F_{rec} [kN]
AZ 8	6	0,46	0,32	0,15	0,31	0,27	0,06	0,09	–

 F_{rec} : Recommended loads incl. safety factor of 7

Standing toilet installation set

FRH



Advantages



- Fast and easy installation of standing toilets and bidets to the floor
- Sets with plugs FX (+ hex-head screws 6x60) can be used for nearly all building materials, see page 23
- Patented support angles (+ chipboard screw 5x45) can be used for many different standing toilets and bidets
- Flanged bushes protect ceramics
- Screws in stainless steel ensure corrosion resistance

Approvals and certificates



Suitable building materials

Very suitable



- Concrete
- Natural stone
- Solid brick
- Solid sand-lime brick
- Lightweight solid concrete blocks
- Aerated concrete
- Hollow brick
- Hollow sand-lime brick
- Lightweight hollow concrete blocks
- Gypsum blocks

Suitable to a limited extent



- Plasterboard/ Fibreboard
- Chipboard

Mounting

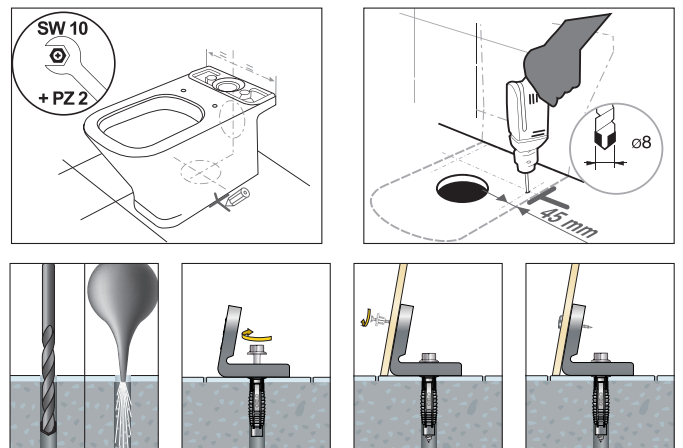

Standing toilet installation set FRH

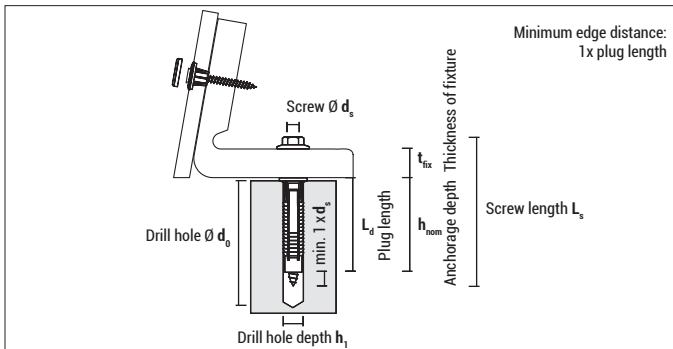

FRH

Type	Art-No	Set contains	d_0 [mm]	$h_1 \geq$ [mm]	L_d [mm]	h_{nom} [mm]	$t_{fix} \leq$ [mm]	€/Set	[Sets]
FRH	FRH100	2 plugx FX 8 2 hex-head screw 6 x 60, zinc flake coating 2 patented support angles 2 chipboard screws 5 x 45, stainless steel 2 flanged bushes 2 cover caps, chrome	8	55	40	39	10		100

Sets are packed in PVC bags

Recommended loads F_{rec} using wood screws with the largest applicable screw diameter and full anchorage depth

Type	Screw \varnothing d_s [mm]	Concrete F_{rec} [kN]	Solid stone Mz 12 F_{rec} [kN]	Solid sand- lime brick KS 12 F_{rec} [kN]	Aerated concrete AAC2 F_{rec} [kN]	Aerated concrete AAC4 F_{rec} [kN]	Hollow brick HLz 12 F_{rec} [kN]	Hollow sand- lime brick KSL 12 F_{rec} [kN]
FX 8	6	0,52	0,50	0,50	0,10	0,14	0,23	0,60

F_{rec} : Recommended loads incl. safety factor of 7

Vanity installation set

WT



Advantages



- Suitable for fastening of wash basins
- Set with multi-purpose plug MZ can be used for nearly all building materials, see page 31
- Hanger bolts with TX recess for easy and fast installation
- Solid washers for strong hold
- Plastic washers with collar protect the ceramic



Suitable building materials

Very suitable

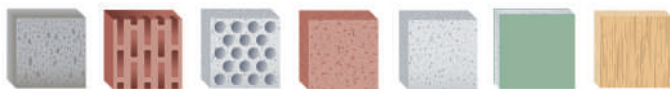

- Concrete
- Natural stone
- Solid brick
- Solid sand-lime brick
- Lightweight solid concrete blocks
- Aerated concrete
- Gypsum blocks
- Hollow brick
- Hollow sand-lime brick
- Lightweight hollow concrete blocks
- Plasterboard/ Fibreboard
- Chipboard



Mounting

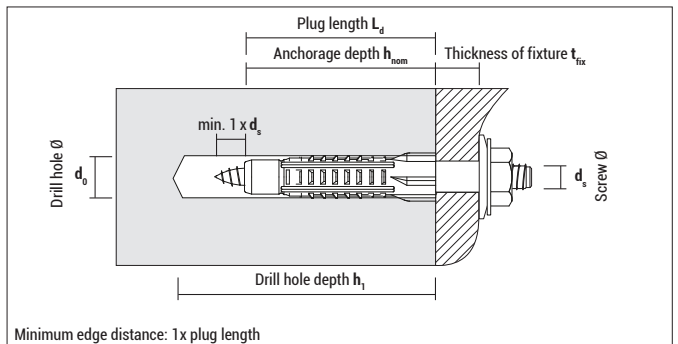
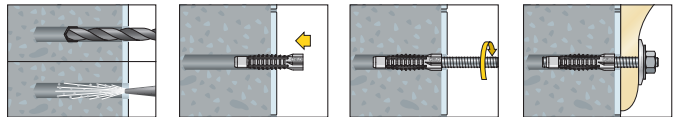

Type	Art-No	Set contains	d_0 [mm]	$h_1 \geq$ [mm]	L_d [mm]	h_{nom} [mm]	$t_{fix} \leq$ [mm]	€ / Set	[Sets]
10 x 140	910140WT	2 plugs MZ 14 2 hanger bolts M10 x 140 2 flanged bushes 2 washers 35 x 11 x 1,5 2 hex-head nuts M10	14	100	79	79	40		50

Sets are packed in PVC bags



Type	Art-No	d_0 [mm]	L_d [mm]	h_{nom} [mm]	d_s [mm]	L_s [mm]	Type of screw	€ / Blister	[pcs]	[Blister]
WT	5WT2	14	79	79	10	140			2	10

Urinal installation set UB

Advantages

- Suitable for the fastening of urinals and hanging toilets
- Set with multi-purpose plug MZ can be used for nearly all building materials, see page 31
- Hanger bolts with TX recess for easy and fast installation
- Stable washers for strong hold
- Plastic washers with collar protect the ceramic
- Hexagonal recess in the cover cap secures perfect lock on the nut



Suitable building materials

Very suitable



- Concrete
- Natural stone
- Solid brick
- Solid sand-lime brick
- Lightweight solid concrete blocks
- Aerated concrete
- Gypsum blocks
- Hollow brick
- Hollow sand-lime brick
- Lightweight hollow concrete blocks
- Plasterboard/ Fibreboard
- Chipboard

Mounting

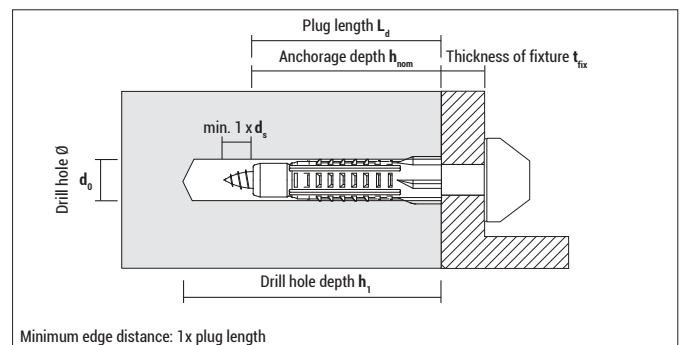
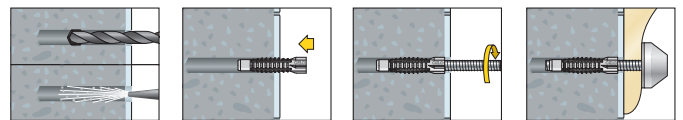

UB

Type	Art-No	Set contains	d_0 [mm]	$h_1 \geq$ [mm]	L_d [mm]	h_{nom} [mm]	$t_{fix} \leq$ [mm]	€/Set	[Sets]
10 x 140 white	91UB	2 plug MZ 14 2 hanger bolts M10 x 140 2 flanged bushes 2 washers 35 x 11 x 1,5 2 hex-head nuts M10 2 cover caps white	14	100	79	79	40		20
10 x 140 chrome	9CRUB	2 plug MZ 14 2 hanger bolts M10 x 140 2 flanged bushes 2 washers 35 x 11 x 1,5 2 hex-head nuts M10 2 cover caps chrome	14	100	79	79	40		20

Sets are packed in PVC bags

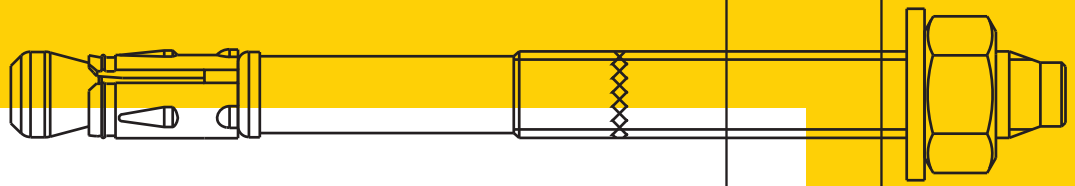

Metal Anchors

ME		131	BTS4		160
DA		133	BTS5		161
SA plus		135	BTS6		163
SA / SA-N		140	BTS		166
BAZ plus		142	BTS M		169
BAZ2		145	SLA		171
BAZ		148	ZA		173
BAZ-H		152	Dnbolt®		175
BAP		154			
BA A4		158			

Brass plug ME

Advantages

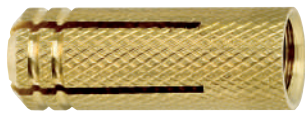

- The knurling ensures good antirotation behaviour
- Quick removal of fixture
- Setting depth of the metric screw matches approximately the anchor length (also depends on solidity of base material)
- No special setting tool needed
- Corrosion resistant anchor, therefore also suitable for outdoor use



Suitable building materials

Very suitable



- Concrete
- Natural stone
- Solid brick
- Solid sand-lime brick

Mounting

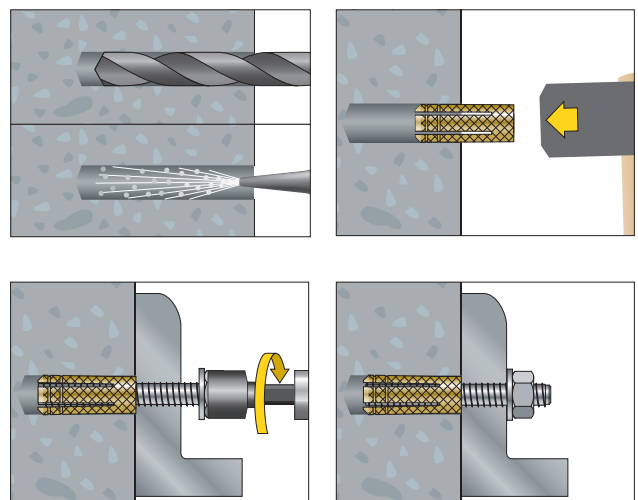

Brass plug ME

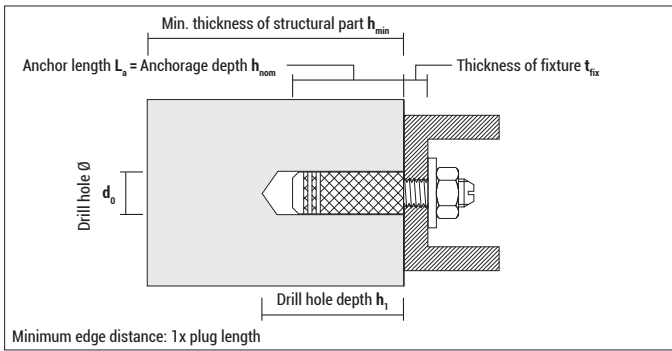

ME

Type	Art-No	d_0 [mm]	$h_1 \geq$ [mm]	$L_a = h_{nom}$ [mm]	Thread	€ / 100 pcs	[pcs]	[pcs]
ME 4	9L4ME	5	18	16	M4		100	3.200
ME 5	9L5ME	6	22	20	M5		100	3.200
ME 6	9L6ME	8	27	23	M6		100	4.000
ME 8	9L8ME	10	35	30	M8		50	2.000
ME 10	9L10ME	12	39	34	M10		50	1.500
ME 12	9L12ME	15	46	40	M12		25	750
ME 16	9L16ME	20	50	44	M16		25	350



Blister ME



Type	Art-No	d_0 [mm]	$h_1 \geq$ [mm]	L_a [mm]	Thread	€ / Blister	[pcs]	[Blister]
ME 6	5L6ME5	8	27	23	M6		5	10
ME 8	5L8ME4	10	35	30	M8		4	10

Loads, spacing and edge distance

Type	Concrete C20/25 F_{rec} [kN]	Solid brick Mz 12 F_{rec} [kN]	Solid sand-lime brick KS 12 F_{rec} [kN]	Spacing S [mm]	Edge distance C [mm]	h_{min} [mm]
ME 4	0,40	0,30	0,30	60	40	50
ME 5	0,45	0,40	0,40	60	50	50
ME 6	0,65	0,55	0,55	60	60	60
ME 8	1,10	0,90	0,90	80	80	70
ME 10	1,60	1,30	1,30	80	80	80
ME 12	2,20	1,60	1,60	100	100	100
ME 16	3,30	2,30	2,30	120	120	150

F_{rec} : Recommended loads incl. safety factor

Suspended ceiling anchor

DA



Advantages



Suspended ceiling anchor DA 30/5



Suspended ceiling anchor DA 60/35

- Approved as a fixing system for multiple use in non-structural applications in cracked and non-cracked concrete
- Low anchorage depth of only 25 mm, this means less risk of hitting rebars! You save time and money
- Reduced impact force for fatigue-free work
- Especially suited for suspended ceilings

Approvals and certificates



For multiple use for non-structural applications in cracked concrete

see assessment

Suitable building materials

Very suitable



• Concrete



• Solid brick

Mounting

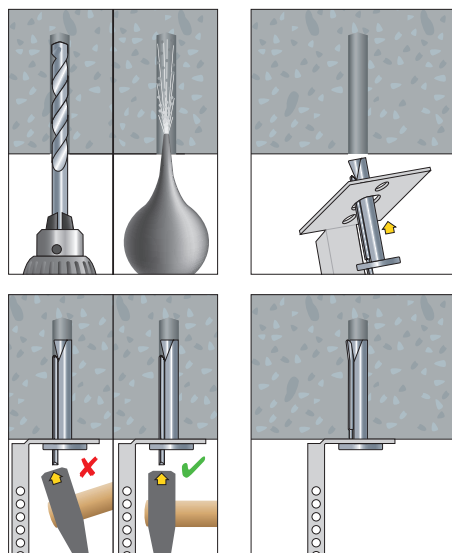

Suspended ceiling anchor DA

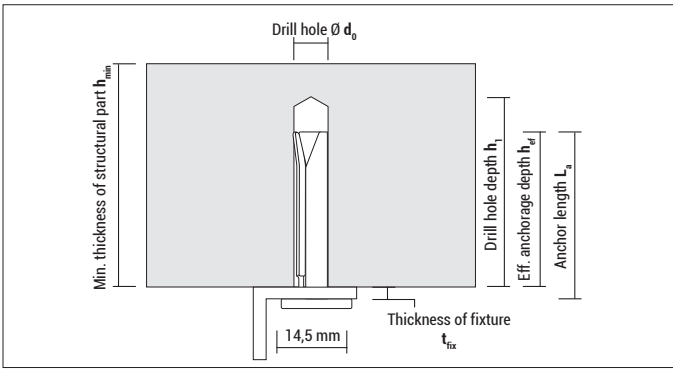

DA, zinc plated

Type	Art-No	d ₀ [mm]	h ₁ ≥ [mm]	h _{ef} ≥ [mm]	L _a [mm]	t _{fix} ≤ [mm]		€/ 100 pcs	[pcs]	[pcs]
DA 6x30/5	965DA	6	30	25	30	4,5	●		100	1.800
DA 6x60/35	9635DA	6	30	25	60	35	●		100	1.200

Loads, spacing and edge distance

Type	Concrete ≥ C20/25 F _{per} [kN]	Solid brick Mz 12 F _{rec} [kN]	Solid sand-lime brick KS 12 F _{rec} [kN]	Spacing S _{min} [mm]	Edge distance C _{min} [mm]	Min. thickness of structural part h _{min} [mm]
DA 6x30/5	0,95	0,60	0,40	200	150	80
DA 6x60/35	0,95	0,60	0,40	200	150	80

F_{per}: Permissible load in all directions.

F_{per} includes the resistances' partial safety factors as per ETA assessment and a partial safety factor on the action of $v_F = 1,4$

F_{rec}: Recommended loads in all directions incl. safety factor of 5 (solid brick and solid sand-lime brick are not part of the ETA)

h_{min}, S_{min} and C_{min} must be observed.

Drop-in anchor SA plus & SAK plus

Advantages



SA plus, zinc plated



SAK plus with lip, zinc plated



Setting tool ESW PRO



Setting tool ESW

- The drop-in anchor SA plus is approved for single use in non-cracked concrete and for multiple use for non-structural applications in cracked concrete
- The high expansion ability of the drop-in anchor enables a low drill hole depth and low anchorage depth
- The setting tool is necessary for the correct installation

Suitable building materials

Very suitable



- Concrete



Approvals and certificates



see assessment
M6 - M10

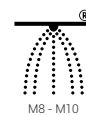

Mounting

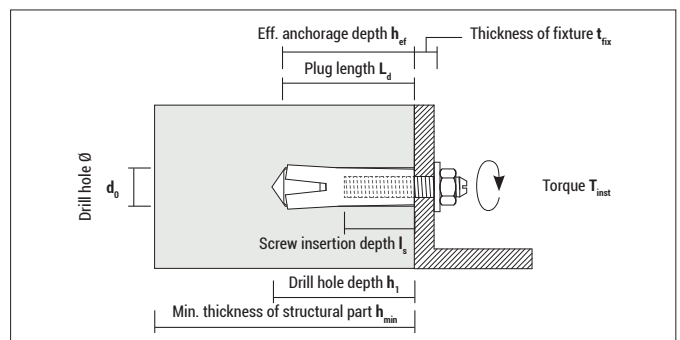
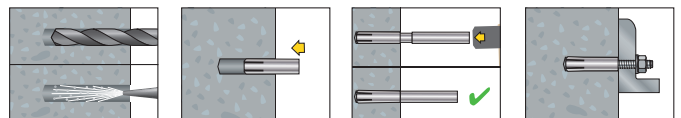

Drop-in anchor SA plus & SAK plus

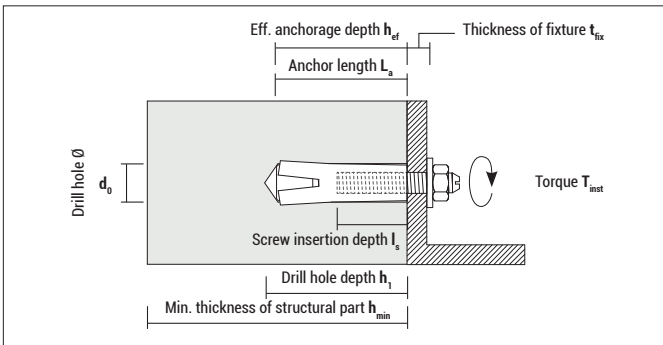

SA plus, zinc plated

Type	Art-No	d_0 [mm]	h_1 [mm]	$L_a = h_{ef}$ [mm]	$l_{s, min-max}^*$ [mm]	Thread		€/ 100 pcs	[pcs]	[pcs]
SA plus 6	96SAP	8	27	25	6 - 11	M6	●		100	1.800
SA plus 8	98SAP	10	32	30	8 - 13	M8	●		100	1.000
SA plus 10	910SAP	12	43	40	10 - 16	M10	●		50	500
SA plus 12	912SAP	15	54	50	12 - 23	M12	●		50	300
SA plus 16	916SAP	20	70	65	16 - 32	M16	●		25	150

* Min. / max. screw insertion depth in drop-in anchor



SAK plus with lip, zinc plated

Type	Art-No	d_0 [mm]	h_1 [mm]	$L_a = h_{ef}$ [mm]	$l_{s, min-max}^*$ [mm]	Thread		€/ 100 pcs	[pcs]	[pcs]
SAK plus 6	96SAPK	8	27	25	6 - 11	M6	●		100	1.800
SAK plus 8x25	9825SAPK	10	27	25	6 - 12	M8	●		100	1.000
SAK plus 8	98SAPK	10	32	30	8 - 13	M8	●		100	1.000
SAK plus 10x25	91025SAPK	12	27	25	8 - 12	M10	●		50	900
SAK plus 10	910SAPK	12	43	40	10 - 16	M10	●		50	500
SAK plus 12	912SAPK	15	54	50	12 - 23	M12	●		50	300
SAK plus 16	916SAPK	20	70	65	16 - 32	M16	●		25	150

* Min. / max. screw insertion depth in drop-in anchor



ESW PRO for SA plus, SAK plus, SA and SA-N with hand protection

Type	Art-No	Suitable for	€/ pcs	[pcs]
ESW PRO 6	96ESWP	SA plus 6, SAK plus 6, SA-N 6		1
ESW PRO 8	98ESWP	SA plus 8, SAK plus 8 and SAK plus 8x25, SA-N 8		1
ESW PRO 10x25	91025ESWP	SAK plus 10x25		1
ESW PRO 10	910ESWP	SA plus 10, SAK plus 10 and SA-N 10		1
ESW PRO 12	912ESWP	SA plus 12, SAK plus 12 and SA 12D, SA-N 12		1
ESW PRO 16	916ESWP	SA plus 16, SAK plus 16 and SA-N 16		1

Drop-in anchor SA plus & SAK plus



ESW for SA plus, SAK plus, SA and SA-N

Type	Art-No	Suitable for	€ / pcs	 [pcs]
ESW 6	96ESW	SA plus 6, SAK plus 6, SA-N 6		1
ESW 8	98ESW	SA plus 8, SAK plus 8 and SAK plus 8x25, SA-N 8		1
ESW 10x25	91025ESW	SAK plus 10x25		1
ESW 10	910ESW	SA plus 10, SAK plus 10 and SA-N 10		1
ESW 12	912ESW	SA plus 12, SAK plus 12 and SA 12D, SA-N 12		1
ESW 16	916ESW	SA plus 16, SAK plus 16 and SA-N 16		1

Loads, spacing and edge distance for single anchor in non-cracked concrete C20/25

Type	Permissible tension load ^{1),2)} [screw 4.6-8.8]	Permissible shear load ^{1),2)}		Permissible bending moment ²⁾		Spacing S_{min} [mm]	Edge distance C_{min} [mm]	Min. thickness of structural part h_{min} [mm]	Max. torque $T_{inst. \leq}$ [Nm]	Ø of clearance hole in fixture d_f [mm]
	N_{per} [kN]	[screw 4.6] V_{per} [kN]	[screw 8.8] V_{per} [kN]	[screw 4.6] M_{per} [Nm]	[screw 8.8] M_{per} [Nm]					
SA/SAK plus 8	3,6	3,1	4,0	6,4	17,1	105	105	100	8	9
SA/SAK plus 10	4,8	4,5	4,5	12,8	34,2	105	140	100	15	12
SA/SAK plus 12	6,3	7,3	7,3	22,4	59,8	125	175	120	35	14
SA/SAK plus 16	10,5	12,2	12,2	56,8	151,7	180	230	160	60	18

¹⁾ Permissible loads for single anchor without influence of spacing and edge distance.

²⁾ Load figures include the resistances' partial safety factors as per ETA assessment and a partial safety factor on the action of $v_F = 1,4$

³⁾ For higher concrete strengths up to C50/55 the values increase by max. 55%.

h_{min} , S_{min} and C_{min} must be observed.

Loads, spacing and edge distance for multiple use for non-structural applications in cracked concrete C20/25-C50/60

Type	Permissible load in any direction ^{1),2)} [screw 4.6-8.8]	Permissible bending moment ²⁾		Spacing S_{min} [mm]	Edge distance C_{min} [mm]	Min. thickness of structural part h_{min} [mm]	Max. torque $T_{inst. \leq}$ [Nm]	Ø of clearance hole in fixture d_f [mm]
	F_{per} [kN]	[screw 4.6] M_{per} [Nm]	[screw 8.8] M_{per} [Nm]					
SA/SAK plus 6	0,5	2,6	7,0	70	105	100	4	7
SAK plus 8x25	1,0	6,4	17,1	120	110	100	8	9
SA/SAK plus 8	1,2	6,4	17,1	105	105	100	8	9
SAK plus 10x25	1,0	12,8	34,2	130	140	100	15	12
SA/SAK plus 10	3,0	12,8	34,2	105	140	100	15	12

¹⁾ Permissible loads without influence of spacing and edge distance.

²⁾ Load figures include the resistances' partial safety factors as per ETA assessment and a partial safety factor on the action of $v_F = 1,4$

h_{min} , S_{min} and C_{min} must be observed.

Drop-in anchor SAK plus 8x25 & SAK plus 10x25

Advantages



SAK plus with lip, zinc plated



Setting tool ESW PRO (p. 136)



Setting tool ESW (p. 137)

- The drop-in anchor SAK plus 8x25 and 10-25 are approved as a fixing system for multiple use in non-structural applications in cracked and non-cracked concrete
- The anchor is also approved for fixing in precast pre-stressed hollow core slabs
- Low anchorage depth of only 25 mm, this means time saving
- The high expansion ability of the drop-in anchor enables a small drill hole and low anchorage depth
- The setting tool is necessary for the correct installation

Suitable building materials

Very suitable



- Concrete
- Precast pre-stressed hollow core slabs



Approvals and certificates

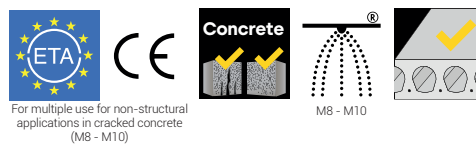

Mounting

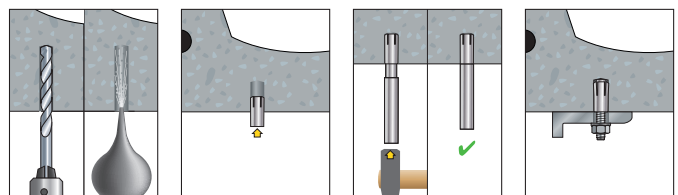

Drop-in anchor SAK plus 8x25 & 10-25

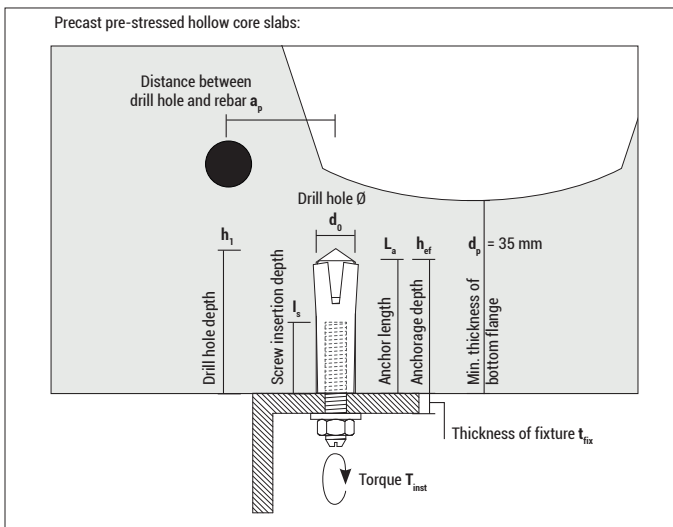

SAK plus with lip, zinc plated

Type	Art-No	d_0 [mm]	h_1 [mm]	$L_a = h_{ef}$ [mm]	$l_{s, min-max}^*$ [mm]	Thread	ETA	€/100 pcs	[pcs]	[pcs]
SAK plus 8x25	9825SAPK	10	27	25	6 - 12	M8	●		100	1.000
SAK plus 10x25	91025SAPK	12	27	25	8 - 12	M10	●		50	900

* Min. / max. screw insertion depth in drop-in anchor

Loads, spacing and edge distance for multiple use for non-structural applications in precast pre-stressed hollow core slabs C45/55

Type	Permissible load in any direction ^{1,2)} [screw 4.6-8.8] F_{per} [kN]	Permissible bending moment ²⁾ [screw 4.6] [screw 8.8] M_{per} [Nm] M_{per} [Nm]		Spacing S_{min} [mm]	Edge distance C_{min} [mm]	Min. thickness of bottom flange d_p [mm]	Max. torque $T_{inst, \leq}$ [Nm]	Distance between drill hole and rebar $a_{p, min}$ [mm]	Ø of clearance hole in fixture d_f [mm]
	SAK plus 8x25	1,2	6,4	17,1	180	150	35	8	50
SAK plus 10x25	1,6	12,8	34,2	180	150	35	15	50	12

¹⁾ Permissible loads without influence of spacing and edge distance.

²⁾ Load figures include the resistances' partial safety factors as per ETA assessment and a partial safety factor on the action of $\gamma_F = 1,4$

S_{min} , C_{min} and $a_{p, min}$ must be observed.

Drop-in anchor

SA 12D

SA-N



Advantages



Drop-in anchor SA 12D, zinc plated



Drop-in anchor SA-N, stainless steel A4



Setting tool ESW PRO



Setting tool ESW

- SA 12D with the reinforced anchor sleeve is especially suitable for temporary fastenings of diamond core rigs.
- SA-N is made of stainless steel A4, therefore the anchor has a high corrosion resistance and can be used for outdoor applications.
- The high expansion ability of the drop-in anchor enables a low anchorage and drill hole depth.
- For a correct and fast installation it is essential to use the setting tool ESW or ESW Pro with hand protection to achieve a high expansion and secure anchorage in the base material.

Suitable building materials

Very suitable



- Concrete

Approvals and certificates



Mounting

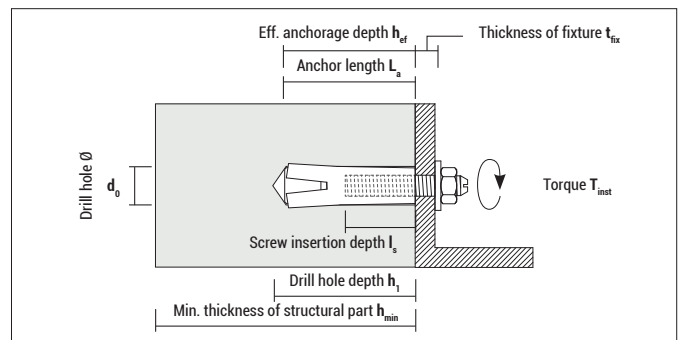
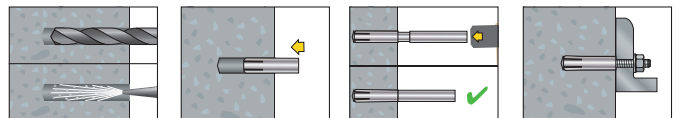

Drop-in anchor SA and SA N



SA 12D, zinc plated without approval, recommended for fixing diamond core rigs

Type	Art-No	d ₀ * [mm]	h ₁ [mm]	L _a [mm]	l _{s min-max} ** [mm]	Thread	€/100 pcs	[pcs]	[pcs]
SA 12D	91216SA	16	50	50	12 - 18	M12		50	250

* reinforced anchor sleeve by 1 mm

** Min. / max. screw insertion depth in drop-in anchor



SA-N, stainless steel A4 without approval

A4
STAINLESS
STEEL

Type	Art-No	d ₀ [mm]	h ₁ [mm]	L _a [mm]	l _{s min-max} * [mm]	Thread	€/100 pcs	[pcs]	[pcs]
SA-N 6	9X6SAN	8	25	25	6 - 12	M6		100	1.000
SA-N 8	9X8SAN	10	30	30	8 - 13	M8		100	1.000
SA-N 10	9X10SAN	12	40	40	10 - 15	M10		50	500
SA-N 12	9X12SAN	15	50	50	12 - 18	M12		50	400
SA-N 16	9X16SAN	20	65	65	16 - 23	M16		25	125

* Min. / max. screw insertion depth in drop-in anchor



ESW for SA plus, SAK plus, SA and SA-N

Type	Art-No	Suitable for	€/pcs	[pcs]
ESW 6	96ESW	SA plus 6, SAK plus 6, SA-N 6		1
ESW 8	98ESW	SA plus 8, SAK plus 8 and SAK plus 8x25, SA-N 8		1
ESW 10	910ESW	SA plus 10, SAK plus 10 and SA-N 10		1
ESW 12	912ESW	SA plus 12, SAK plus 12 and SA 12D, SA-N 12		1
ESW 16	916ESW	SA plus 16, SAK plus 16 and SA-N 16		1

Setting tool ESW PRO with hand protection see page 136

Loads, spacing and edge distance in non-cracked concrete

Type	Concrete C20/25 F _{rec} [kN]	Spacing S _{min} [mm]	Edge distance C _{min} [mm]	Min. thickness of structural part h _{min} [mm]	Max. Torque T _{inst} ≤ [Nm]
SA-N 6	1,2	70	80	100	5
SA-N 8	1,8	90	90	100	8
SA-N 10	3,6	120	120	120	15
SA/SA-N 12	5,7	160	160	150	35
SA-N 16	7,4	220	240	200	60

F_{rec}: Recommended loads incl. safety factor of 4

Bolt anchor BAZ plus



Advantages

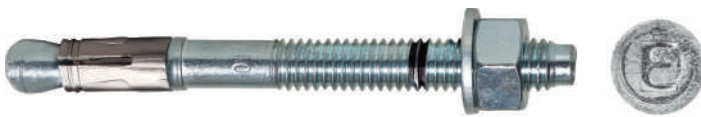

BAZ plus, zinc plated



BAZ plus A4, stainless steel A4



BAZ plus HCR, stainless steel, high corrosion resistant

- High-performance bolt anchor for cracked concrete.
- Very high load values even with small edge and axial distances; usable also in difficult installation situations
- Suitable for usage under seismic action (C1/C2)
- Two different setting depths for the dimensions M10 and M12 for higher application flexibility
- Setting depth marking ring for quick installation
- Length marking on top of the BAZ plus

Approvals and certificates

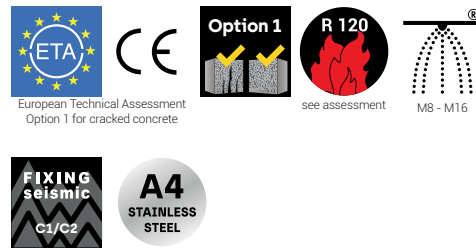

Suitable building materials

Very suitable



- Concrete



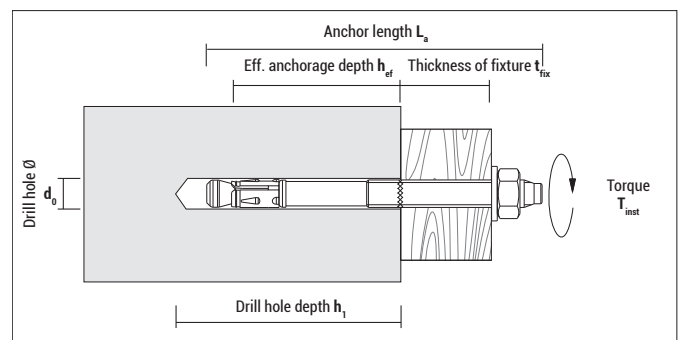
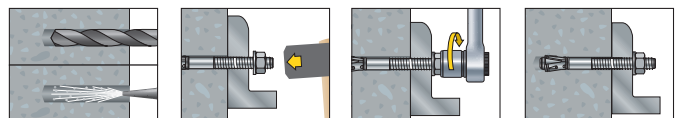

Mounting



Bolt anchor BAZ plus





BAZ plus, zinc plated

Type	Art-No	d ₀ [mm]	h ₁ ≥ [mm]	h _{ef} ≥ [mm]	L _a [mm]	t _{fix} ≤ [mm]	Thread		€/100 pcs	 [pcs]	 [pcs]
8x75/10	9875BAZP	8	60	48	75	10	M8	●		50	250
8x95/30	9895BAZP	8	60	48	95	30	M8	●		50	250
8x115/50	98115BAZP	8	60	48	115	50	M8	●		40	200
8x150/85	98150BAZP	8	60	48	150	85	M8	●		40	200
10x72/10	91072BAZP	10	55	40	72	10	M10	●		40	200
10x92/10	91092BAZP	10	55/75	40/60	92	30/10	M10	●		40	200
10x102/20	910102BAZP	10	55/75	40/60	102	40/20	M10	●		25	125
10x112/30	910112BAZP	10	55/75	40/60	112	50/30	M10	●		25	125
10x132/50	910132BAZP	10	55/75	40/60	132	70/50	M10	●		25	125
10x162/80	910162BAZP	10	55/75	40/60	162	100/80	M10	●		25	125
12x88/10	91288BAZP	12	70	50	88	10	M12	●		20	100
12x103/5	912103BAZP	12	70/90	50/70	103	25/5	M12	●		20	100
12x118/20	912118BAZP	12	70/90	50/70	118	40/20	M12	●		20	100
12x128/30	912128BAZP	12	70/90	50/70	128	50/30	M12	●		20	100
12x148/50	912148BAZP	12	70/90	50/70	148	70/50	M12	●		20	100
12x163/65	912163BAZP	12	70/90	50/70	163	85/65	M12	●		20	100
12x178/80	912178BAZP	12	70/90	50/70	178	100/80	M12	●		20	100
16x123/5	916123BAZP	16	110	85	123	5	M16	●		10	50
16x138/20	916138BAZP	16	110	85	138	20	M16	●		10	50
16x168/50	916168BAZP	16	110	85	168	50	M16	●		10	50
16x178/60	916178BAZP	16	110	85	178	60	M16	●		10	50



BAZ plus A4, stainless steel A4

A4
STAINLESS
STEEL

Type	Art-No	d ₀ [mm]	h ₁ ≥ [mm]	h _{ef} ≥ [mm]	L _a [mm]	t _{fix} ≤ [mm]	Thread		€/100 pcs	 [pcs]	 [pcs]
8x75/10 A4	9X875BAZP	8	60	48	75	10	M8	●		50	250
8x95/30 A4	9X895BAZP	8	60	48	95	30	M8	●		50	250
8x115/50 A4	9X8115BAZP	8	60	48	115	50	M8	●		40	200
8x150/85 A4	9X8150BAZP	8	60	48	150	85	M8	●		40	200
10x72/10 A4	9X1072BAZP	10	55	40	72	10	M10	●		40	200
10x92/10 A4	9X1092BAZP	10	55/75	40/60	92	30/10	M10	●		40	200
10x102/20 A4	9X10102BAZP	10	55/75	40/60	102	40/20	M10	●		25	125
10x112/30 A4	9X10112BAZP	10	55/75	40/60	112	50/30	M10	●		25	125
10x132/50 A4	9X10132BAZP	10	55/75	40/60	132	70/50	M10	●		25	125
10x162/80 A4	9X10162BAZP	10	55/75	40/60	162	100/80	M10	●		25	125
12x88/10 A4	9X1288BAZP	12	70	50	88	10	M12	●		20	100
12x103/5 A4	9X12103BAZP	12	70/90	50/70	103	25/5	M12	●		20	100
12x118/20 A4	9X12118BAZP	12	70/90	50/70	118	40/20	M12	●		20	100
12x128/30 A4	9X12128BAZP	12	70/90	50/70	128	50/30	M12	●		20	100
12x148/50 A4	9X12148BAZP	12	70/90	50/70	148	70/50	M12	●		20	100
12x163/65 A4	9X12163BAZP	12	70/90	50/70	163	85/65	M12	●		20	100
12x178/80 A4	9X12178BAZP	12	70/90	50/70	178	100/80	M12	●		20	100
16x123/5 A4	9X16123BAZP	16	110	85	123	5	M16	●		10	50
16x138/20 A4	9X16138BAZP	16	110	85	138	20	M16	●		10	50
16x168/50 A4	9X16168BAZP	16	110	85	168	50	M16	●		10	50
16x178/60 A4	9X16178BAZP	16	110	85	178	60	M16	●		10	50



BAZ plus HCR, stainless steel, high corrosion resistant

Type	Art-No	d ₀ [mm]	h ₁ ≥ [mm]	h _{ef} ≥ [mm]	L _a [mm]	t _{fix} ≤ [mm]	Thread		€ / 100 pcs	 [pcs]	 [pcs]
8x75/10 HCR	9HCR875BAZP	8	60	48	75	10	M8	●	on request	50	250
10x92/10 HCR	9HCR1092BAZP	10	55 / 75	40 / 60	92	30 / 10	M10	●	on request	40	200
10x112/30 HCR	9HCR10112BAZP	10	55 / 75	40 / 60	112	50 / 30	M10	●	on request	25	125

No stock item; only available on request

Installation parameters

BAZ plus Size	BAZ plus Type	M8		M10		M12		M16	
		BAZ plus zinc plated	BAZ plus stainless steel A4 / HCR	BAZ plus zinc plated	BAZ plus stainless steel A4 / HCR	BAZ plus zinc plated	BAZ plus stainless steel A4 / HCR	BAZ plus zinc plated	BAZ plus stainless steel A4 / HCR
Torque	T _{inst} [Nm]	15	20	30	45	60		110	
Width across flats	SW [mm]	13		17		19		24	
Ø of clearance hole in fixture	d _i [mm]	9		12		14		18	
Washer outer Ø x thickness	[mm]	17 x 1,6		21 x 2,0		24 x 2,5		30 x 3,0	

Spacing and edge distance

BAZ plus Size		M8	M10	M12	M16		
Effective anchorage depth	h _{ef} [mm]	48	40	60	70	85	
Minimum edge distance	C _{min} [mm]	40	50	50	60	65	
	for S ≥ [mm]	55	190	100	215	110	150
Minimum spacing	S _{min} [mm]	35	50	40	55	60	65
	for C ≥ [mm]	50	95	60	110	70	95
Characteristic edge distance	C _{cr} [mm]	72	60	90	75	105	127
Characteristic spacing	S _{cr} [mm]	144	120	180	150	210	254
Min. thickness of structural part	h _{min} [mm]	100	100	120	100	140	170
Reduced min. thickness of structural part ¹⁾	h _{min,red} [mm]	80	–	100	–	–	–

If underrun the char. spacing or edge distance (C_{cr} or S_{cr}) the loads must be reduced. h_{min}, S_{min} and C_{min} must be observed.

¹⁾ Reduced min. thickness of structural part only in non-cracked concrete.

Permissible loads

BAZ plus Size		M8	M10	M12	M16		
Effective anchorage depth	h _{ef} [mm]	48	40	60	70	85	
Permissible tension load ^{1), 2)} for single anchor without influence of spacing and edge distance in cracked concrete C20/25 ³⁾							
BAZ plus zinc plated	N _{per} [kN]	4,0	4,1	5,7	5,8	7,6	11,4
BAZ plus stainless steel A4 / HCR	N _{per} [kN]	4,0	4,1	5,7	5,8	7,6	11,4
Permissible tension load ^{1), 2)} for single anchor without influence of spacing and edge distance in non-cracked concrete C20/25 ³⁾							
BAZ plus zinc plated	N _{per} [kN]	5,2	5,7	9,0	8,3	11,9	17,1
BAZ plus stainless steel A4 / HCR	N _{per} [kN]	5,2	5,7	9,0	8,3	11,9	17,1
Permissible shear load ^{1), 2)} for single anchor without influence of spacing and edge distance in cracked concrete C20/25 ³⁾							
BAZ plus zinc plated	V _{per} [kN]	7,2	11,7	11,7	17,1	17,1	30,9
BAZ plus stainless steel A4 / HCR	V _{per} [kN]	9,0	11,7	11,7	17,2	19,7	36,4
Permissible shear load ^{1), 2)} for single anchor without influence of spacing and edge distance in non-cracked concrete C20/25 ³⁾							
BAZ plus zinc plated	V _{per} [kN]	7,2	11,7	11,7	17,1	17,1	30,9
BAZ plus stainless steel A4 / HCR	V _{per} [kN]	9,0	11,7	11,7	19,7	19,7	39,2
Permissible bending moment ^{1), 2)}							
BAZ plus zinc plated	M _{per} [Nm]	15,0	29,1	51,4			125,6
BAZ plus stainless steel A4 / HCR	M _{per} [Nm]	14,3	29,1	51,4			122,7

¹⁾ For further information please refer to the ETA assessment

²⁾ Load figures include the resistances' partial safety factors as per ETA assessments and a partial safety factor on the action of γ_F = 1,4.

Load figures apply for a rebar spacing S ≥ 15 cm or alternatively for a rebar spacing S ≥ 10 cm in combination with a rebar diameter of d_s ≤ 10 mm.

³⁾ For higher concrete strengths up to C50/60 the values increase by max. 58%.

Bolt anchor BAZ2



Advantages

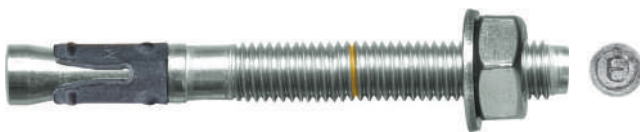

BAZ2, zinc plated

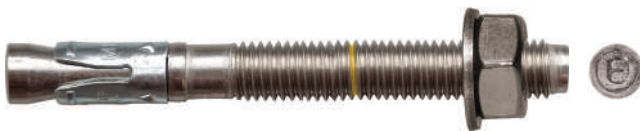

BAZ2 A4, stainless steel A4

- Bolt anchor with high load values for cracked and non-cracked concrete and suitable for use under seismic action (C1 and C2)
- High load values even with small edge and axial distances; reliable also in difficult installation situation
- Setting depth marking ring for quick installation
- Length marking on top of the BAZ2

Approvals and certificates

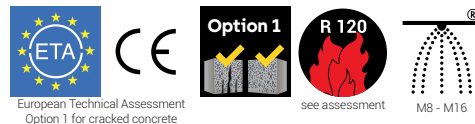

Mounting

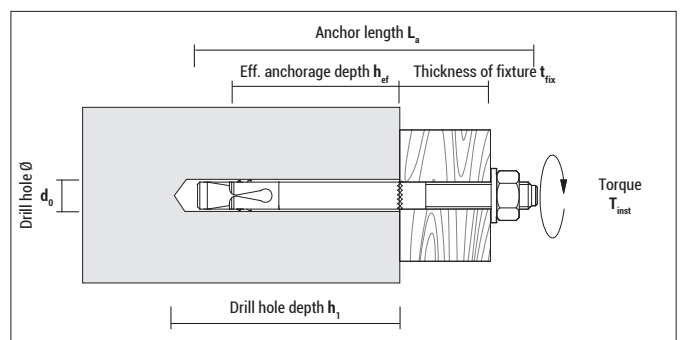
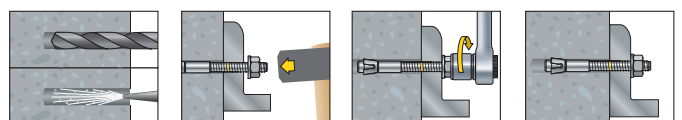

Suitable building materials

Very suitable



- Concrete



Suitable to a limited extent

- Dense natural stone (up to M8)

Bolt anchor BAZ2



BAZ2, zinc plated

Type	Art-No	d ₀ [mm]	h ₁ ≥ [mm]	h _{ef} ≥ [mm]	L _a [mm]	t _{fix} ≤ [mm]	Thread	Drive	ETA	€ / 100 pcs	[pcs]	[pcs]
6x50/2	9650BAZ2	6	44	34	50	2	M6	SW10	–		150	750
6x65/15	9665BAZ2	6	46	36	65	15	M6	SW10	–		100	500
8x50/2	9850BAZ2	8	42	30	50	2	M8	SW13	–		100	500
8x75/9	9875BAZ2	8	60	48	75	9	M8	SW13	●		50	250
8x95/29	9895BAZ2	8	60	48	95	29	M8	SW13	●		50	250
8x115/49	98115BAZ2	8	60	48	115	49	M8	SW13	●		40	200
8x150/84	98150BAZ2	8	60	48	150	84	M8	SW13	●		40	200
10x90/10	91090BAZ2	10	75	60	90	10	M10	SW17	●		40	200
10x100/20	910100BAZ2	10	75	60	100	20	M10	SW17	●		25	125
10x110/30	910110BAZ2	10	75	60	110	30	M10	SW17	●		25	125
10x130/50	910130BAZ2	10	75	60	130	50	M10	SW17	●		25	125
10x160/80	910160BAZ2	10	75	60	160	80	M10	SW17	●		25	125
12x100/4	912100BAZ2	12	85	70	100	4	M12	SW19	●		20	100
12x120/24	912120BAZ2	12	85	70	120	24	M12	SW19	●		20	100
12x130/34	912130BAZ2	12	85	70	130	34	M12	SW19	●		20	100
12x150/54	912150BAZ2	12	85	70	150	54	M12	SW19	●		20	100
12x160/64	912160BAZ2	12	85	70	160	64	M12	SW19	●		20	100
12x180/84	912180BAZ2	12	85	70	180	84	M12	SW19	●		20	100
16x125/8	916125BAZ2	16	105	85	125	8	M16	SW24	●		10	50
16x140/23	916140BAZ2	16	105	85	140	23	M16	SW24	●		10	50
16x170/53	916170BAZ2	16	105	85	170	53	M16	SW24	●		10	50
16x180/63	916180BAZ2	16	105	85	180	63	M16	SW24	●		10	50

successor product of BAZ p. 148, can be ordered as soon as BAZ is no longer in stock



BAZ2 A4, stainless steel A4



Type	Art-No	d ₀ [mm]	h ₁ ≥ [mm]	h _{ef} ≥ [mm]	L _a [mm]	t _{fix} ≤ [mm]	Thread	Drive	ETA	€ / 100 pcs	[pcs]	[pcs]
8x50/2 A4	9X850BAZ2	8	42	30	50	2	M8	SW13	–		100	500
8x75/9 A4	9X875BAZ2	8	60	48	75	9	M8	SW13	●		50	250
8x95/29 A4	9X895BAZ2	8	60	48	95	29	M8	SW13	●		50	250
8x115/49 A4	9X8115BAZ2	8	60	48	115	49	M8	SW13	●		40	200
10x90/10 A4	9X1090BAZ2	10	75	60	90	10	M10	SW17	●		40	200
10x100/20 A4	9X10100BAZ2	10	75	60	100	20	M10	SW17	●		25	125
10x110/30 A4	9X10110BAZ2	10	75	60	110	30	M10	SW17	●		25	125
10x130/50 A4	9X10130BAZ2	10	75	60	130	50	M10	SW17	●		25	125
12x100/4 A4	9X12100BAZ2	12	85	70	100	4	M12	SW19	●		20	100
12x120/24 A4	9X12120BAZ2	12	85	70	120	24	M12	SW19	●		20	100
12x130/34 A4	9X12130BAZ2	12	85	70	130	34	M12	SW19	●		20	100
12x150/54 A4	9X12150BAZ2	12	85	70	150	54	M12	SW19	●		20	100
12x160/64 A4	9X12160BAZ2	12	85	70	160	64	M12	SW19	●		20	100
16x125/8 A4	9X16125BAZ2	16	105	85	125	8	M16	SW24	●		10	50
16x140/23 A4	9X16140BAZ2	16	105	85	140	23	M16	SW24	●		10	50
16x170/53 A4	9X16170BAZ2	16	105	85	170	53	M16	SW24	●		10	50

successor product of BAZ A4 p. 148, can be ordered as soon as BAZ A4 is no longer in stock

Bolt anchor BAZ2

Installation parameters

BAZ2 Size		M6*	M8	M10		M12	M16
				BAZ2 zinc plated	BAZ2 A4		
Torque	T_{inst} [Nm]	7	15	40	30	60	100
Width across flats	SW [mm]	10	13	17		19	24
Ø of clearance hole in fixture	d_f [mm]	7	9	12		14	18
Washer outer Ø x thickness	[mm]	12 x 1,6	17 x 1,6	21 x 2,0		24 x 2,5	30 x 3,0

* Not part of the approval

Spacing and edge distance

BAZ2 Size		M8		M10		M12		M16	
		BAZ2 zinc plated	BAZ2 A4	BAZ2 zinc plated	BAZ2 A4	BAZ2 zinc plated	BAZ2 A4	BAZ2 zinc plated	BAZ2 A4
Effective anchorage depth	h_{ef} [mm]	48		60		70		85	
Minimum edge distance	C_{min} [mm]	45	47	45	52	55	62	70	75
Minimum spacing	S_{min} [mm]	40	42	40	47	60	57	65	75
Characteristic edge distance	C_{cr} [mm]	72		90		105		128	
Characteristic spacing	S_{cr} [mm]	144		180		210		255	
Min. thickness of structural part	h_{min} [mm]	80	100	90	120	105	140	130	170

If underrun the char. spacing or edge distance (C_{cr} or S_{cr}) the loads must be reduced. h_{min} , S_{min} and C_{min} must be observed.

Loads

BAZ2 Size	BAZ2 Type	M8		M10		M12		M16	
		BAZ2 zinc plated	BAZ2 A4	BAZ2 zinc plated	BAZ2 A4	BAZ2 zinc plated	BAZ2 A4	BAZ2 zinc plated	BAZ2 A4
Permissible tension loads for single anchor without influence of spacing and edge distance ^{1), 2)}									
In cracked concrete C20/25 ³⁾	N_{zul} [kN]	2,8	4,1	5,2	6,7	7,1	7,5	12,9	10,7
In non-cracked concrete C20/25 ³⁾	N_{zul} [kN]	4,0	5,7	8,6	7,6	13,3	8,7	16,2	15,3
Permissible shear loads for single anchor without influence of spacing and edge distance ^{1), 2)}									
In cracked concrete C20/25	V_{zul} [kN]	5,5	5,4	9,9	10,8	14,5	15,7	25,7	25,7
In non-cracked concrete C20/25	V_{zul} [kN]	6,3	6,8	9,9	10,8	14,5	15,7	26,9	31,4
Zulässiges Biegemoment	M_{zul} [Nm]	12,9	15,0	25,6	29,9	44,9	52,4	114,2	133,2

¹⁾ For further information please refer to the ETA assessment

²⁾ Load figures include the resistances' partial safety factors as per ETA assessment and a partial safety factor on the action of $\gamma_F = 1,4$.

Load figures apply for a rebar spacing $S \geq 15$ cm or alternatively for a rebar spacing $S \geq 10$ cm in combination with a rebar diameter of $d_s \leq 10$ mm..

³⁾ For higher concrete strengths up to C50/60 the values increase by max. 58 %

Recommended loads for the not approved anchor sizes M6, M8

Type	Anchorage depth h_{ef} [mm]	non-cracked concrete C20/25 N_{empf} [kN]	non-cracked concrete C20/25 V_{empf} [kN]
BAZ2 6x50/2	34	1,6	2,0
BAZ2 6x65/15	36	1,8	2,0
BAZ2 8x50/2	30	2,6	2,6

N_{rec} : recommended tension load; V_{rec} : recommended shear load

Bolt anchor BAZ



Advantages



BAZ, zinc plated



BAZ A4, stainless steel A4



BAZ HD, hot-dip galvanized

- Bolt anchor with good load values for cracked and non-cracked concrete and suitable for use under seismic action (C1)
- High load values even with small edge and axial distances; reliable also in difficult installation situations
- Large assortment in several materials

Approvals and certificates



European Technical Assessment
Option 1 for cracked concrete



see assessment



M8 - M16



Mounting

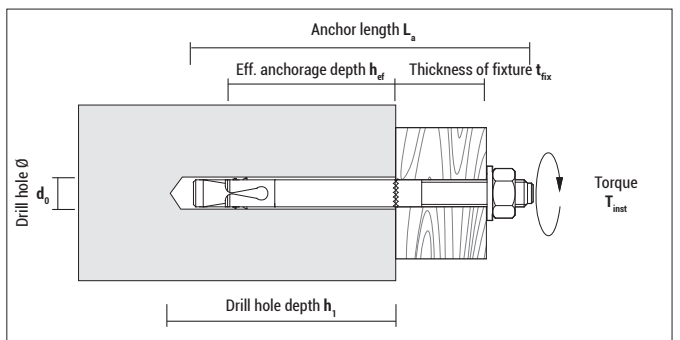
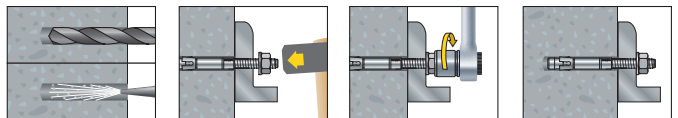

Suitable building materials

Very suitable



- Concrete





Suitable to a limited extent

- Dense natural stone (up to M8)

Bolt anchor BAZ



BAZ, zinc plated



Type	Art-No	d ₀ [mm]	h ₁ ≥ [mm]	h _{ef} ≥ [mm]	L _a [mm]	t _{fix} ≤ [mm]	Thread		€ / 100 pcs	 [pcs]	 [pcs]
6x40/2	9640BAZ	6	35	25	40	2	M6	–		150	750
6x65/15	9665BAZ	6	45	35	65	15	M6	–		100	500
8x52/2	9852BAZ	8	45	30	52	2	M8	–		100	500
8x72/10	9872BAZ	8	60	45	72	10	M8	●		50	250
8x92/30	9892BAZ	8	60	45	92	30	M8	●		50	250
8x112/50	98112BAZ	8	60	45	112	50	M8	●		40	200
8x147/85	98147BAZ	8	60	45	147	85	M8	●		40	200
10x92/10	91092BAZ	10	75	60	92	10	M10	●		40	200
10x102/20	910102BAZ	10	75	60	102	20	M10	●		25	125
10x112/30	910112BAZ	10	75	60	112	30	M10	●		25	125
10x132/50	910132BAZ	10	75	60	132	50	M10	●		25	125
10x162/80	910162BAZ	10	75	60	162	80	M10	●		25	125
12x103/5	912103BAZ	12	90	70	103	5	M12	●		20	100
12x118/20	912118BAZ	12	90	70	118	20	M12	●		20	100
12x128/30	912128BAZ	12	90	70	128	30	M12	●		20	100
12x148/50	912148BAZ	12	90	70	148	50	M12	●		20	100
12x163/65	912163BAZ	12	90	70	163	65	M12	●		20	100
12x178/80	912178BAZ	12	90	70	178	80	M12	●		20	100
16x123/5	916123BAZ	16	110	85	123	5	M16	●		10	50
16x138/20	916138BAZ	16	110	85	138	20	M16	●		10	50
16x178/60	916178BAZ	16	110	85	178	60	M16	●		10	50

Discontinued article, delivery while stocks last, successor product: BAZ2 - see p. 145



BAZ A4, stainless steel A4

A4
STAINLESS
STEEL

Type	Art-No	d ₀ [mm]	h ₁ ≥ [mm]	h _{ef} ≥ [mm]	L _a [mm]	t _{fix} ≤ [mm]	Thread		€ / 100 pcs	 [pcs]	 [pcs]
6x40/2 A4	9X640BAZ	6	35	25	40	2	M6	–		150	750
6x65/15 A4	9X665BAZ	6	45	35	65	15	M6	–		100	500
8x52/2 A4	9X852BAZ	8	45	30	52	2	M8	–		100	500
8x112/50 A4	9X8112BAZ	8	60	45	112	50	M8	●		40	200
10x60/10 A4	9X1060BAZ	10	38	23	60	10	M10	–		50	250
10x102/20 A4	9X10102BAZ	10	75	60	102	20	M10	●		25	125
10x112/30 A4	9X10112BAZ	10	75	60	112	30	M10	●		25	125
10x132/50 A4	9X10132BAZ	10	75	60	132	50	M10	●		25	125
12x103/5 A4	9X12103BAZ	12	90	70	103	5	M12	●		20	100
12x118/20 A4	9X12118BAZ	12	90	70	118	20	M12	●		20	100
12x128/30 A4	9X12128BAZ	12	90	70	128	30	M12	●		20	100
12x148/50 A4	9X12148BAZ	12	90	70	148	50	M12	●		20	100
12x163/65 A4	9X12163BAZ	12	90	70	163	65	M12	●		20	100
16x123/5 A4	9X16123BAZ	16	110	85	123	5	M16	●		10	50
16x138/20 A4	9X16138BAZ	16	110	85	138	20	M16	●		10	50
16x168/50 A4	9X16168BAZ	16	110	85	168	50	M16	●		10	50

Discontinued article, delivery while stocks last, successor product: BAZ2 A4 - see p. 145

Bolt anchor BAZ

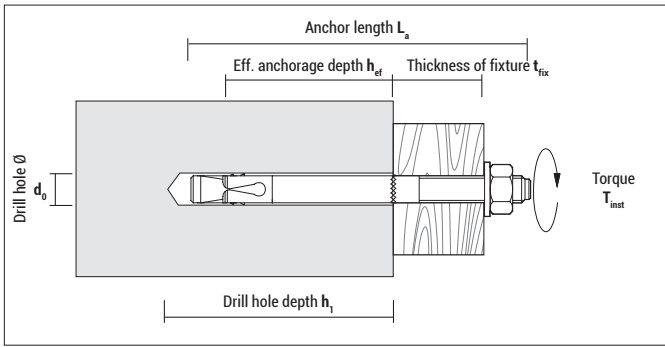

Blister BAZ, zinc plated

Type	Art-No	d_0 [mm]	$h_1 \geq$ [mm]	$h_{ef} \geq$ [mm]	L_a [mm]	$t_{fix} \leq$ [mm]	Thread	ETA	€ / Blister	[pcs]	[Blister]
8x72/10	5874BAZ2	8	60	45	72	10	M8	●		2	10
10x92/10	51095BAZ2	10	75	60	92	10	M10	●		2	10
12x118/20	512115BAZ2	12	90	70	118	20	M12	●		2	10

Discontinued article, delivery while stocks last



BAZ HD, hot-dip galvanized

Type	Art-No	d_0 [mm]	$h_1 \geq$ [mm]	$h_{ef} \geq$ [mm]	L_a [mm]	$t_{fix} \leq$ [mm]	Thread	ETA	€ / 100 pcs	[pcs]	[pcs]
6x40/2 HD	9HD640BAZ	6	35	25	40	2	M6	–		150	750
6x65/15 HD	9HD665BAZ	6	45	35	65	15	M6	–		100	500
8x52/2 HD	9HD852BAZ	8	45	30	52	2	M8	–		100	500
8x92/30 HD	9HD892BAZ	8	60	45	92	30	M8	●		50	250
8x112/50 HD	9HD8112BAZ	8	60	45	112	50	M8	●		40	200
8x147/85 HD	9HD8147BAZ	8	60	45	147	85	M8	●		40	200
10x60/10 HD	9HD1060BAZ	10	38	23	60	10	M10	–		50	250
10x92/10 HD	9HD1092BAZ	10	75	60	92	10	M10	●		40	200
10x102/20 HD	9HD10102BAZ	10	75	60	102	20	M10	●		25	125
10x112/30 HD	9HD10112BAZ	10	75	60	112	30	M10	●		25	125
10x132/50 HD	9HD10132BAZ	10	75	60	132	50	M10	●		25	125
10x162/80 HD	9HD10162BAZ	10	75	60	162	80	M10	●		25	125
12x103/5 HD	9HD12103BAZ	12	90	70	103	5	M12	●		20	100
12x118/20 HD	9HD12118BAZ	12	90	70	118	20	M12	●		20	100
12x128/30 HD	9HD12128BAZ	12	90	70	128	30	M12	●		20	100
12x148/50 HD	9HD12148BAZ	12	90	70	148	50	M12	●		20	100
12x163/65 HD	9HD12163BAZ	12	90	70	163	65	M12	●		20	100
12x178/80 HD	9HD12178BAZ	12	90	70	178	80	M12	●		20	100
16x123/5 HD	9HD16123BAZ	16	110	85	123	5	M16	●		10	50
16x138/20 HD	9HD16138BAZ	16	110	85	138	20	M16	●		10	50
16x168/50 HD	9HD16168BAZ	16	110	85	168	50	M16	●		10	50
16x178/60 HD	9HD16178BAZ	16	110	85	178	60	M16	●		10	50

Discontinued article, delivery while stocks last, successor product: BA plus HD - see p. 154

Bolt anchor BAZ

Installation parameters

BAZ Size		M6*	M8		M10	M12		M16
BAZ Type			BAZ BAZ HD	BAZ A4 BAZ HCR		BAZ BAZ HD	BAZ A4 BAZ HCR	
Torque	T_{inst} [Nm]	7	20 / 15**	20	35	50	70	120
Width across flats	SW [mm]	10	13		17	19		24
Ø of clearance hole in fixture	d_f [mm]	7	9		12	14		18
Washer outer Ø x thickness	[mm]	12 x 1,6	17 x 1,6		21 x 2,0	24 x 2,5		30 x 3,0

* Not part of the assessment

** 20 for BAZ, 15 for BAZ HD

Spacing and edge distance

BAZ Size		M8	M10	M12	M16
Effective anchorage depth	h_{ef} [mm]	45	60	70	85
Minimum edge distance	C_{min} [mm]	50	50	55	85
	for $S \geq$ [mm]	50	100	145	150
Minimum spacing	S_{min} [mm]	50	55	60	70
	for $C \geq$ [mm]	50	80	90	120
Characteristic edge distance	C_{cr} [mm]	68	90	105	128
Characteristic spacing	S_{cr} [mm]	135	180	210	255
Min. thickness of structural part	h_{min} [mm]	100	120	140	170

If underun the char. spacing or edge distance (C_{cr} or S_{cr}) the loads must be reduced. h_{min} , S_{min} and C_{min} must be observed.

Loads

BAZ Size		M8		M10		M12		M16	
BAZ Type		BAZ zinc plated BAZ HD	BAZ A4 BAZ HCR	BAZ zinc plated BAZ HD	BAZ A4 BAZ HCR	BAZ zinc plated BAZ HD	BAZ A4 BAZ HCR	BAZ zinc plated- BAZ HD	BAZ A4 BAZ HCR
Permissible tension loads for single anchor without influence of spacing and edge distance ^{1), 2)}									
In cracked concrete C20/25 ³⁾	N_{per} [kN]	2,0	2,0	3,6	3,6	4,8	4,8	9,5	9,5
In non-cracked concrete C20/25 ³⁾	N_{per} [kN]	3,6	3,6	6,3	6,3	7,9	7,9	16,7	16,7
Permissible shear loads for single anchor without influence of spacing and edge distance ^{1), 2)}									
In cracked concrete C20/25	V_{per} [kN]	5,0	5,0	10,3	9,7	13,1	14,3	25,1	25,7
In non-cracked concrete C20/25	V_{per} [kN]	5,7	6,3	10,3	9,7	13,1	14,3	25,1	26,9
Permissible bending moment	M_{per} [Nm]	12,0	12,6	27,4	25,7	41,1	45,1	106,3	114,3

¹⁾ For further information please refer to the ETA assessment²⁾ Load figures include the resistances' partial safety factors as per ETA assessment and a partial safety factor on the action of $\gamma_F = 1,4$.Load figures apply for a rebar spacing $S \geq 15$ cm or alternatively for a rebar spacing $S \geq 10$ cm in combination with a rebar diameter of $d_s \leq 10$ mm.³⁾ For higher concrete strengths up to C50/60 the values increase by max. 31%.

Recommended loads for the not approved anchor sizes M6, M10 in non-cracked concrete C20/25

Type	N_{rec} [kN]	V_{rec} [kN]	Anchorage depth h_{ef} [mm]
BAZ 6x40/2	1,6	2,0	25
BAZ 6x65/15	1,8	2,5	35
BAZ 8x52/2	2,6	4,8	30
BAZ 10x60/10	1,6	2,0	23

 N_{rec} : recommended tension load; V_{rec} : recommended shear load

Bolt anchor BAZ-H



Advantages



BAZ-H, zinc plated with large washer according to ISO 7094 (DIN 440) for woodworking

- Bolt anchor in long version with large washer according to ISO 7094 (DIN 440) for woodworking
- Approved for cracked concrete
- Small setting depth
- Long thread for high mounting flexibility

Approvals and certificates

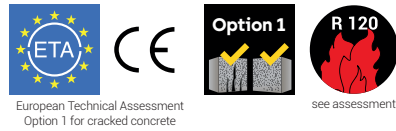

Suitable building materials

Very suitable



- Concrete

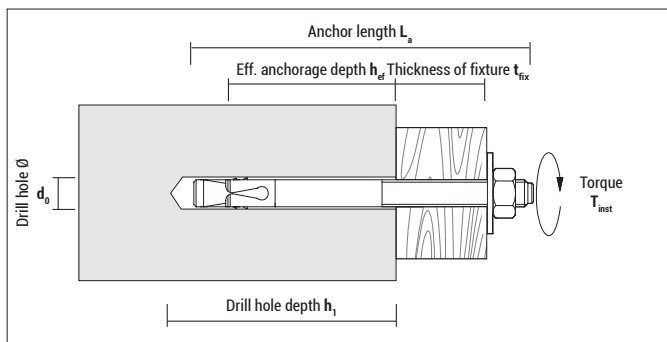

Mounting

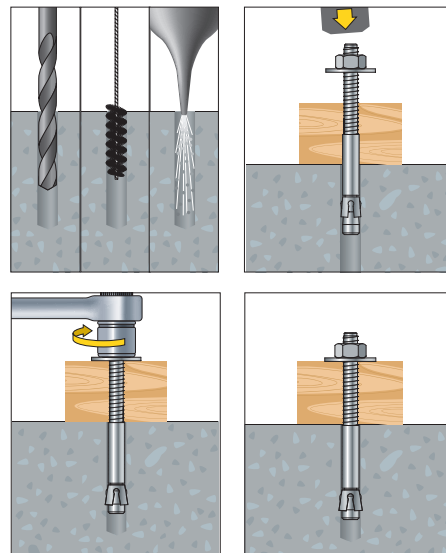



BAZ-H, zinc plated

Type	Art-No	d_0 [mm]	$h_1 \geq$ [mm]	$h_{ef} \geq$ [mm]	L_a [mm]	$t_{fix} \leq$ [mm]	Thread	ETA	€ / 100 pcs	[pcs]	[pcs]
10x210/140	910210BAZH	10	70	45	210	140	M10	●		20	80
12x203/113	912203BAZH	12	90	62	203	113	M12	●		15	60
12x220/130	912220BAZH	12	90	62	220	130	M12	●		15	60
12x243/153	912243BAZH	12	90	62	243	153	M12	●		15	60
12x258/168	912258BAZH	12	90	62	258	168	M12	●		15	60
12x280/190	912280BAZH	12	90	62	280	190	M12	●		10	40
12x320/230	912320BAZH	12	90	62	320	230	M12	●		10	40
16x220/100	916220BAZH	16	120	88	220	100	M16	●		10	40
16x280/160	916280BAZH	16	120	88	280	160	M16	●		5	20
16x323/203	916323BAZH	16	120	88	323	203	M16	●		5	20
16x370/250	916370BAZH	16	120	88	370	250	M16	●		5	20

Installation parameters

BAZ-H Size		M10	M12	M16
Torque	T_{inst} [Nm]	25	65	110
Width across flats	SW [mm]	17	19	24
Ø of clearance hole in fixture	d_f [mm]	12	14	18
Washer DIN 440 outer Ø x tickness	[mm]	34 x 3	44 x 4	56 x 5

Spacing and edge distance

BAZ-H Size		M10	M12	M16
Effective anchorage depth	h_{ef} [mm]	45	62	88
Minimum edge distance	C_{min} [mm]	70	85	70
Minimum spacing	S_{min} [mm]	60	70	60
Characteristic edge distance	C_{cr} [mm]	68	93	132
Characteristic spacing	S_{cr} [mm]	135	186	264
Min. thickness of structural part	h_{min} [mm]	120	140	160

If underrun the char. spacing or edge distance (C_{cr} or S_{cr}) the loads must be reduced. h_{min} , S_{min} and C_{min} must be observed.

Loads

BAZ-H Size		M10	M12	M16
Permissible centric tension load^{1), 2)} for single anchor without influence of spacing and edge distance in cracked concrete C20/25³⁾				
BAZ-H zinc plated	N_{zul} [kN]	2,9	3,8	8,6
Permissible centric tension load^{1), 2)} for single anchor without influence of spacing and edge distance in non-cracked concrete C20/25³⁾				
BAZ-H zinc plated	N_{zul} [kN]	5,2	8,6	11,9
Permissible shear load^{1), 2)} for single anchor without influence of spacing and edge distance in cracked concrete C20/25³⁾				
BAZ-H zinc plated	V_{zul} [kN]	5,0	16,0	27,1
Permissible shear load^{1), 2)} for single anchor without influence of spacing and edge distance in non-cracked concrete C20/25³⁾				
BAZ-H zinc plated	V_{zul} [kN]	7,1	21,4	32,4
Permissible bending moment^{1), 2)}				
BAZ-H zinc plated	M_{zul} [Nm]	24,3	43,8	95,2

¹⁾ For further information please refer to the ETA assessment

²⁾ Load figures include the resistances' partial safety factors as per ETA assessment and a partial safety factor on the action of $\gamma_F = 1.4$.

Load figures apply for a rebar spacing $S \geq 15$ cm or alternatively for a rebar spacing $S \geq 10$ cm in combination with a rebar diameter of $d_s \leq 10$ mm.

³⁾ For higher concrete strengths up to C50/60 the values increase by max. 58%.

Bolt anchor BA plus



Advantages



BA plus, zinc plated



BA plus, zinc plated with large washer according to ISO 7094 (DIN 440) for woodworking



BA plus, stainless steel A4



BA plus, stainless steel A2



BA plus, hot-dipped HD

- Bolt anchor with excellent load values in non-cracked concrete
- Wide range for woodworking with large washer according to ISO 7094 (DIN 440)
- Setting depth marking ring for quick installation
- Long thread for all sizes for higher mounting flexibility

Suitable building materials

Very suitable



- Concrete



Suitable to a limited extent

- Dense natural stone (up to M8)

Approvals and certificates



European Technical Assessment
Option 7 for non-cracked concrete



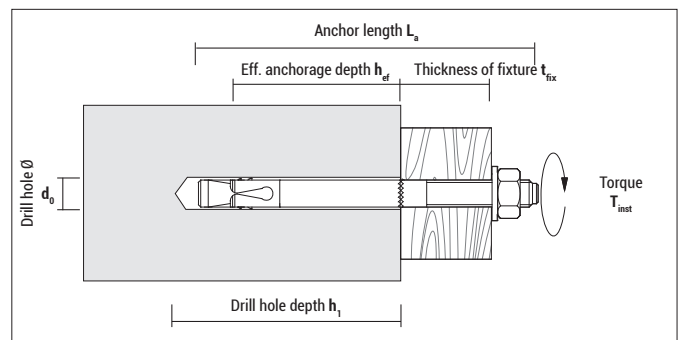
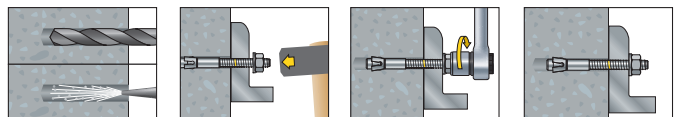

Mounting







BA plus, zinc plated

Type	Art-No	d ₀ [mm]	h ₁ ≥ [mm]	h _{ef} ≥ [mm]	L _a [mm]	t _{fix} ≤ [mm]	Thread		€ / 100 pcs	 [pcs]	 [pcs]
6x45/5	9645BAP	6	38	25	45	5	M6	–		100	500
6x60/10	9660BAP	6	48	35	60	10	M6	●		100	500
6x80/30	9680BAP	6	48	35	80	30	M6	●		100	500
6x100/50	96100BAP	6	48	35	100	50	M6	●		100	500
8x50/5	9850BAP	8	40	25	50	5	M8	–		100	500
8x60/10	9860BAP	8	45	30	60	10	M8	–		50	250
8x75/10	9875BAP	8	60	45	75	10	M8	●		50	250
8x85/20	9885BAP	8	60	45	85	20	M8	●		50	250
8x95/30	9895BAP	8	60	45	95	30	M8	●		50	250
8x115/50	98115BAP	8	60	45	115	50	M8	●		40	200
8x135/70	98135BAP	8	60	45	135	70	M8	●		40	200
10x60/10	91060BAP	10	42	27	60	10	M10	–		50	250
10x75/10	91075BAP	10	55	40	75	10	M10	–		50	250
10x85/10	91085BAP	10	65	50	85	10	M10	●		40	200
10x92/17	91092BAP	10	65	50	92	17	M10	●		40	200
10x105/30	910105BAP	10	65	50	105	30	M10	●		25	125
10x125/50	910125BAP	10	65	50	125	50	M10	●		25	125
10x145/70	910145BAP	10	65	50	145	70	M10	●		25	125
10x175/100	910175BAP	10	65	50	175	100	M10	●		25	125
12x70/2	91270BAP	12	58	38	70	2	M12	–		40	200
12x110/10	912110BAP	12	90	70	110	10	M12	●		20	100
12x120/20	912120BAP	12	90	70	120	20	M12	●		20	100
12x130/30	912130BAP	12	90	70	130	30	M12	●		20	100
12x150/50	912150BAP	12	90	70	150	50	M12	●		20	100
12x180/80	912180BAP	12	90	70	180	80	M12	●		20	100
16x95/10	91695BAP	16	75	50	95	10	M16	–		15	75
16x135/15	916135BAP	16	110	85	135	15	M16	●		10	50
16x150/30	916150BAP	16	110	85	150	30	M16	●		10	50
16x180/60	916180BAP	16	110	85	180	60	M16	●		10	50
16x200/80	916200BAP	16	110	85	200	80	M16	●		10	50
20x110/10	920110BAP	20	90	60	110	10	M20	–		10	40
20x160/20	920160BAP	20	130	100	160	20	M20	●		10	40
20x215/75	920215BAP	20	130	100	215	75	M20	●		6	24
20x270/130	920270BAP	20	130	100	270	130	M20	●		5	20





Blister BA plus, zinc plated

Type	Art-No	d ₀ [mm]	h ₁ ≥ [mm]	h _{ef} ≥ [mm]	L _a [mm]	t _{fix} ≤ [mm]	Thread		€ / Blister	 [pcs]	 [Blister]
8x85/20	5885BA2	8	60	45	85	20	M8	●		2	10
10x92/17	51090BA2	10	65	50	92	17	M10	●		2	10
10x125/50	510120BA2	10	65	50	125	50	M10	●		2	10



BA plus with large washer according to ISO 7094 [DIN 440] for woodworking, zinc plated

Type	Art-No	d ₀ [mm]	h ₁ ≥ [mm]	h _{ef} ≥ [mm]	L _a [mm]	t _{fix} ≤ [mm]	Thread		€ / 100 pcs	 [pcs]	 [pcs]
10x215/140	910215BAP	10	65	50	215	140	M10	●		25	100
12x200/100	912200BAP	12	90	70	200	100	M12	●		20	80
12x220/120	912220BAP	12	90	70	220	120	M12	●		20	80
12x240/140	912240BAP	12	90	70	240	140	M12	●		20	80
12x260/160	912260BAP	12	90	70	260	160	M12	●		20	80
12x300/200	912300BAP	12	90	70	300	200	M12	●		15	60
12x320/220	912320BAP	12	90	70	320	220	M12	●		15	60
16x220/100	916220BAP	16	110	85	220	100	M16	●		10	40
16x270/150	916270BAP	16	110	85	270	150	M16	●		10	40
16x320/200	916320BAP	16	110	85	320	200	M16	●		10	40

CELO



A4
STAINLESS
STEEL

BA plus, stainless steel A4

Type	Art-No	d ₀ [mm]	h ₁ ≥ [mm]	h _{ef} ≥ [mm]	L ₀ [mm]	t _{fix} ≤ [mm]	Thread	ETA	€ / 100 pcs	[pcs]	[pcs]
8x75/10 A4	9X875BAP	8	60	45	75	10	M8	●		50	250
8x95/30 A4	9X895BAP	8	60	45	95	30	M8	●		50	250
8x115/50 A4	9X8115BAP	8	60	45	115	50	M8	●		40	200
10x85/10 A4	9X1085BAP	10	65	50	85	10	M10	●		40	200
10x92/17 A4	9X1092BAP	10	65	50	92	17	M10	●		25	125
10x105/30 A4	9X10105BAP	10	65	50	105	30	M10	●		25	125
10x125/50 A4	9X10125BAP	10	65	50	125	50	M10	●		25	125
10x145/70 A4	9X10145BAP	10	65	50	145	70	M10	●		25	125
12x110/10 A4	9X12110BAP	12	90	70	110	10	M12	●		20	100
12x120/20 A4	9X12120BAP	12	90	70	120	20	M12	●		20	100
12x130/30 A4	9X12130BAP	12	90	70	130	30	M12	●		20	100
12x150/50 A4	9X12150BAP	12	90	70	150	50	M12	●		20	100
16x135/15 A4	9X16135BAP	16	110	85	135	15	M16	●		10	50
16x150/30 A4	9X16150BAP	16	110	85	150	30	M16	●		10	50



A2
STAINLESS
STEEL

BA plus, stainless steel A2

Type	Art-No	d ₀ [mm]	h ₁ ≥ [mm]	h _{ef} ≥ [mm]	L ₀ [mm]	t _{fix} ≤ [mm]	Thread	ETA	€ / 100 pcs	[pcs]	[pcs]
8x75/10 A2	9SX875BAP	8	60	45	75	10	M8	●		50	250
8x95/30 A2	9SX895BAP	8	60	45	95	30	M8	●		50	250
10x92/17 A2	9SX1092BAP	10	65	50	92	17	M10	●		25	125
10x105/30 A2	9SX10105BAP	10	65	50	105	30	M10	●		25	125
10x125/50 A2	9SX10125BAP	10	65	50	125	50	M10	●		25	125
12x110/10 A2	9SX12110BAP	12	90	70	110	10	M12	●		20	100
12x130/30 A2	9SX12130BAP	12	90	70	130	30	M12	●		20	100
12x150/50 A2	9SX12150BAP	12	90	70	150	50	M12	●		20	100
16x150/30 A2	9SX16150BAP	16	110	85	150	30	M16	●		10	50

Delivery time on request



BA plus, hot-dipped HD

Type	Art-No	d ₀ [mm]	h ₁ ≥ [mm]	h _{ef} ≥ [mm]	L ₀ [mm]	t _{fix} ≤ [mm]	Thread	ETA	€ / 100 pcs	[pcs]	[pcs]
6x45/5 HD	9HD645BAP	6	38	25	45	5	M6	–		100	500
6x60/10 HD	9HD660BAP	6	48	35	60	10	M6	–		100	500
8x50/5 HD	9HD850BAP	8	40	25	50	5	M8	–		100	500
8x75/10 HD	9HD875BAP	8	60	45	75	10	M8	●		50	250
8x95/30 HD	9HD895BAP	8	60	45	95	30	M8	●		50	250
8x115/50 HD	9HD8115BAP	8	60	45	115	50	M8	●		40	200
8x135/70 HD	9HD8135BAP	8	60	45	135	70	M8	●		40	200
10x60/10 HD	9HD1060BAP	10	42	27	60	10	M10	–		50	250
10x85/10 HD	9HD1085BAP	10	65	50	85	10	M10	●		40	200
10x92/17 HD	9HD1092BAP	10	65	50	92	17	M10	●		40	200
10x105/30 HD	9HD10105BAP	10	65	50	105	30	M10	●		25	125
10x125/50 HD	9HD10125BAP	10	65	50	125	50	M10	●		25	125
10x175/100 HD	9HD10175BAP	10	65	50	175	100	M10	●		25	125
12x110/10 HD	9HD12110BAP	12	90	70	110	10	M12	●		20	100
12x120/20 HD	9HD12120BAP	12	90	70	120	20	M12	●		20	100
12x130/30 HD	9HD12130BAP	12	90	70	130	30	M12	●		20	100
12x150/50 HD	9HD12150BAP	12	90	70	150	50	M12	●		20	100
12x180/80 HD	9HD12180BAP	12	90	70	180	80	M12	●		20	100
16x135/15 HD	9HD16135BAP	16	110	85	135	15	M16	●		10	50
16x150/30 HD	9HD16150BAP	16	110	85	150	30	M16	●		10	50
16x180/60 HD	9HD16180BAP	16	110	85	180	60	M16	●		10	50

Bolt anchor BA plus

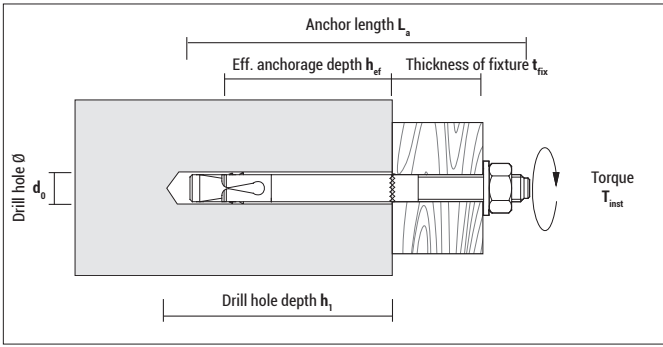

Installation parameters

BA plus Size		M6	M8	M10	M12	M16	M20
Torque	T_{inst} [Nm]	8	15	30	50	110	180
Width across flats	SW [mm]	10	13	17	19	24	30
Ø of clearance hole in fixture	d_f [mm]	7	9	12	14	18	22
Washer outer Ø x thickness	[mm]	12 x 1,6	16 x 1,6	20 x 2 / 34 x 3	24 x 2,5 / 44 x 4	30 x 3 / 56 x 5	37 x 3

Loads, spacing and edge distance BA plus approved sizes M6 - M20

Type	Permissible loads in concrete ¹⁾²⁾³⁾ C 20/25				Permissible bending moment		Spacing ⁴⁾		Edge distance ⁴⁾		Min. thickness of structural part h_{min} [mm]
	Tension N_{per} [kN]		Shear V_{per} [kN]		M_{per} [Nm]		S_{cr} [mm]	S_{min} [mm]	C_{cr} [mm]	C_{min} [mm]	
	zinc plated / HD	A2 / A4	zinc plated / HD	A2 / A4	zinc plated / HD	A2 / A4					
BA plus 6 ⁵⁾	3,6	–	3,1	–	6,1	–	105	50	53	50	100
BA plus 8	7,1	6,7	7,1	5,9	15,0	12,0	135	50	68	50	100
BA plus 10	7,6	7,6	8,3	8,3	28,6	24,0	150	120	75	90	120
BA plus 12	11,4	11,4	15,6	13,5	47,2	42,0	210	70	105	90	160
BA plus 16	12,7	12,7	28,6	25,2	109,4	106,7	255	100	128	100	200
BA plus 20 ⁵⁾	19,5	–	35,9	–	189,2	–	300	160	150	150	200

¹⁾ Permissible loads for single anchor without influence of spacing and edge distance.
²⁾ Load figures include the resistances' partial safety factors as per ETA assessment and a partial safety factor on the action of $\gamma_F = 1,4$.
³⁾ For higher concrete strengths up to C50/60 the values increase by max. 55%.
⁴⁾ If underrun the char. spacing or edge distance (C_{cr} or S_{cr}) the loads must be reduced. h_{min} , S_{min} and C_{min} must be observed.
⁵⁾ Load capacities only valid for galvanized types

Recommended loads for the not approved anchor sizes in non-cracked concrete C20/25

Type	N_{empf} [kN]		V_{empf} [kN]		Eff. anchorage depth h_{ef} [mm]	
	zinc plated	HD	zinc plated	HD	zinc plated	HD
BA plus 6x45/5	1,5	2,5	1,5	2,0	25	35
BA plus 6x60/10	–	2,5	–	2,0	–	35
BA plus 8x50/5	1,5	1,5	1,5	1,5	25	25
BA plus 8x60/10	2,5	–	2,5	–	30	–
BA plus 10x60/10	1,8	1,8	1,8	1,8	27	27
BA plus 10x75/10	2,5	–	2,5	–	40	–
BA plus 12x70/2	2,4	–	2,4	–	38	–
BA plus 16x95/10	4,0	–	4,0	–	50	–
BA plus 20x110/10	6,0	–	6,0	–	60	–

N_{rec} : recommended tension load; V_{rec} : recommended shear load

Bolt anchor BA A4



Advantages



- Bolt anchor made of stainless steel A4 for fast installation in non-cracked concrete
- The BA A4 can be used for a wide range of approval relevant applications for outdoor usage, façade substructures aso.
- High load values and at the same time small edge and axial distances; usable even in tough installation situations

Approvals and certificates

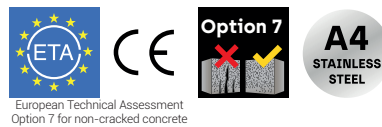

Suitable building materials

Very suitable



- Concrete



Suitable to a limited extent

- Dense natural stone (up to M8)

Mounting

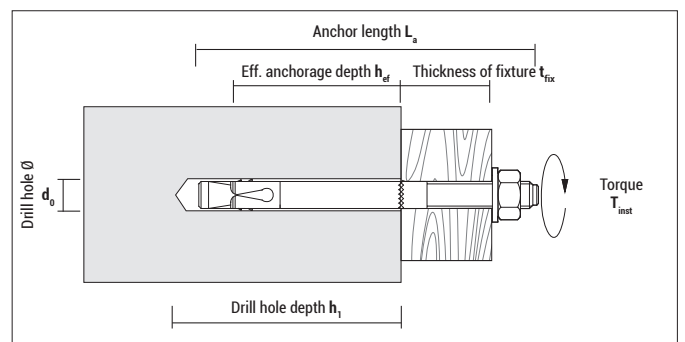
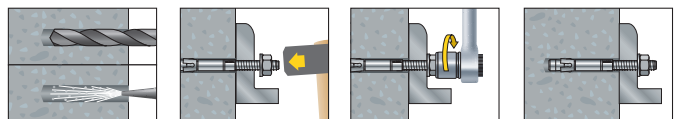

Bolt anchor BA A4

A4
 STAINLESS
 STEEL

BA A4, stainless steel A4

Type	Art-No	d ₀ [mm]	h ₁ ≥ [mm]	h _{ef} ≥ [mm]	L ₀ [mm]	t _{fix} ≤ [mm]	Thread	ETA	€/100 pcs	[pcs]	[pcs]
8x72/10 A4	9X872BA	8	60	45	72	10	M8	●		50	250
8x92/30 A4	9X892BA	8	60	45	92	30	M8	●		50	250
8x112/50 A4	9X8112BA	8	60	45	112	50	M8	●		40	200
10x92/10 A4	9X1092BA	10	75	60	92	10	M10	●		40	200
10x102/20 A4	9X10102BA	10	75	60	102	20	M10	●		25	125
10x112/30 A4	9X10112BA	10	75	60	112	30	M10	●		25	125
10x132/50 A4	9X10132BA	10	75	60	132	50	M10	●		25	125
12x103/5 A4	9X12103BA	12	90	70	103	5	M12	●		20	100
12x118/20 A4	9X12118BA	12	90	70	118	20	M12	●		20	100
12x128/30 A4	9X12128BA	12	90	70	128	30	M12	●		20	100
12x148/50 A4	9X12148BA	12	90	70	148	50	M12	●		20	100
12x163/65 A4	9X12163BA	12	90	70	163	65	M12	●		20	100
16x123/5 A4	9X16123BA	16	110	85	123	5	M16	●		10	50
16x138/20 A4	9X16138BA	16	110	85	138	20	M16	●		10	50
16x168/50 A4	9X16168BA	16	110	85	168	50	M16	●		10	50

Discontinued article, delivery while stocks last, successor product: BA plus A4 - see p. 154

Installation parameters

BA Size		M8	M10	M12	M16
Torque	T _{inst} [Nm]	20	35	70	120
Width across flats	SW [mm]	13	17	19	24
Ø of clearance hole in fixture	d _r [mm]	9	12	14	18
Washer outer Ø x thickness	[mm]	17 x 1,6	21 x 2,0	24 x 2,5	30 x 3,0

Loads, spacing and edge distance BA A4 approved sizes M8 - M16

Type	Permissible loads in concrete ¹⁾²⁾³⁾		Permissible bending moment M _{per} [Nm]	Spacing ⁴⁾		Edge distance ⁴⁾		Min. thickness of structural part h _{min} [mm]
	C 20/25 Tension N _{per} [kN]	C 20/25 Shear V _{per} [kN]		S _{min} [mm]	S _{cr} [mm]	C _{min} [mm]	C _{cr} [mm]	
BA A4 8	3,6	6,3	12,6	50	135	50	68	100
BA A4 10	6,3	9,7	25,7	55	180	50	90	120
BA A4 12	7,9	14,3	45,1	60	210	55	105	140
BA A4 16	16,7	26,9	114,3	70	255	85	128	170

¹⁾ Permissible loads for single anchor without influence of spacing and edge distance..

²⁾ Load figures include the resistances' partial safety factors as per ETA assessment and a partial safety factor on the action of v_F = 1,4.

³⁾ For higher concrete strengths up to C50/60 the values increase by max. 28%.

⁴⁾ If underrun the char. spacing or edge distance (C_{cr} or S_{cr}) the loads must be reduced. h_{min}, S_{min} and C_{min} must be observed.

Concrete screw BTS4



Advantages

- Direct and fast fixing
- Small drill hole with only 4 mm diameter
- Time and cost saving thanks to the low embedment depth of only 18 mm
- Low setting torque: Manual installation without battery screwdriver possible
- Ideal for low edge distances
- Alternative to fixing with plastic plugs e.g. for applications with fire protection requirements
- Suitable for fixing gas nailer accessories like PFT, DFT and CHS
- A problem solver in case of gas nailer setting errors
- Ready-to-install set: Every box of BTS4 includes one SDS drill bit $\varnothing 4$



Mounting

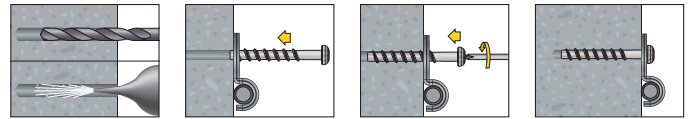

With gas nailer accessory

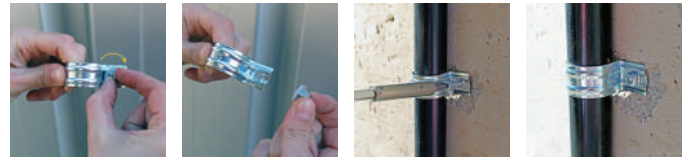

Suitable building materials

Very suitable



Suitable

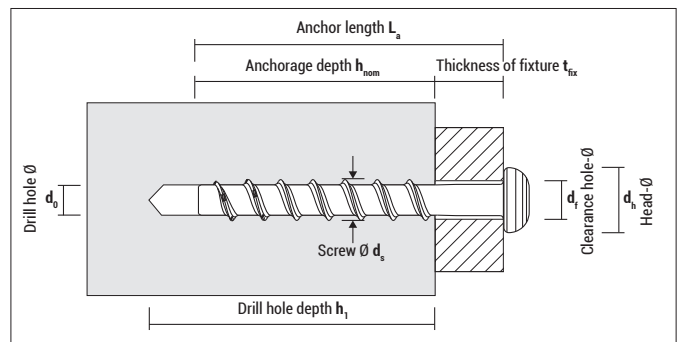
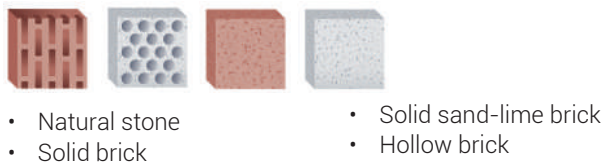

BTS4 PT, zinc plated incl. matching SDS-drill bit $\varnothing 4$ mm, length 110 mm

Type $d_b - L_a$	Art-No	$d_s \times L_a$ [mm]	$h_1 \geq$ [mm]	$h_{nom} \geq$ [mm]	d_f [mm]	d_h [mm]	$t_{rx} \leq$ [mm]	Drive	€/ 100 pcs	[pcs]	[pcs]
4x25/7	9425BTSPT	5,2 x 25	30	18	6	8	7	TX20		250	1.000

Loads

Type	Non-cracked concrete $\geq C20/25$ F_{rec} [kN]	Non-cracked concrete $\geq C50/60$ F_{rec} [kN]
BTS4	0,6	0,75

F_{rec} Recommended loads incl. safety factor 4

Concrete screw BTS5



Advantages

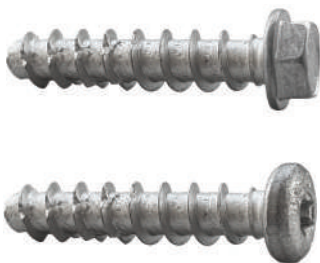

BTS5 B, hex-head

BTS5 PT, pan-head

- Direct and fast fixing
- Small drill hole with only 5 mm diameter
- Low embedment depth of only 25 mm
- Low setting torque: Manual installation without battery screwdriver possible
- Especially suitable for electrical and sanitary fixings
- High recommended load of 80kg in concrete
- Very good corrosion resistance due to zinc flake coating

Suitable building materials

Very suitable



- Concrete

Suitable

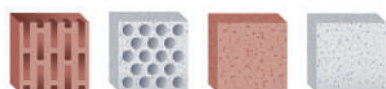

- Natural stone
- Solid brick
- Solid sand-lime brick
- Hollow brick

Mounting

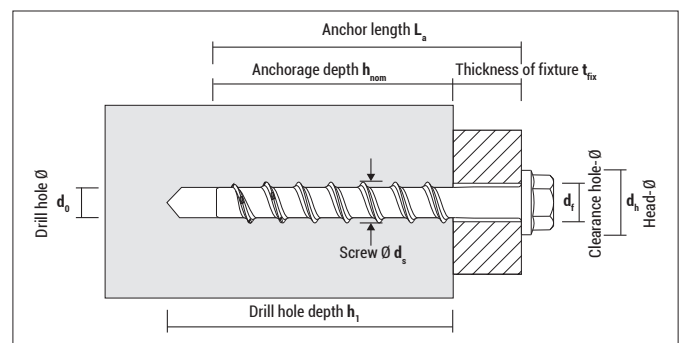
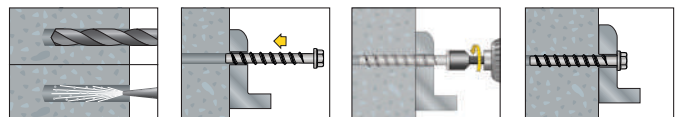

Concrete screw BTS5

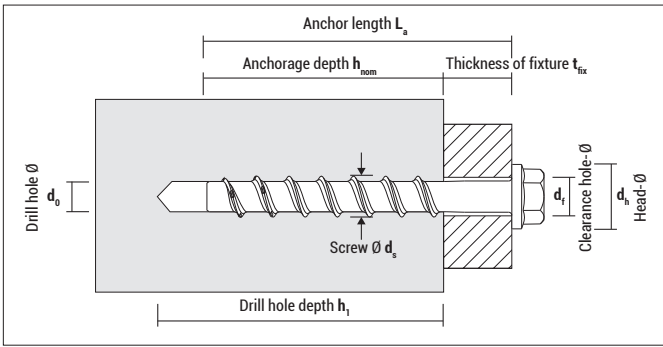

BTS5 B, zinc flake coating with hex-head with integral washer, washer-Ø: 11 mm

Type $d_0 - L_a$	Art-No	$d_s \times L_a$ [mm]	$h_1 \geq$ [mm]	$h_{nom} \geq$ [mm]	d_r [mm]	$t_{fix} \leq$ [mm]	Recess	€/ 100 pcs	[pcs]	[pcs]
5x30/5	9ZG530BTSB	6,4 x 30	35	25	7,5	5	SW8		100	1.800
5x45/20	9ZG545BTSB	6,4 x 45	35	25	7,5	20	SW8		100	1.200
5x60/35	9ZG560BTSB	6,4 x 60	35	25	7,5	35	SW8		100	1.200



BTS5 PT, zinc flake coating with pan-head (TX 25), head-Ø: 10 mm

Type $d_0 - L_a$	Art-No	$d_s \times L_a$ [mm]	$h_1 \geq$ [mm]	$h_{nom} \geq$ [mm]	d_r [mm]	$t_{fix} \leq$ [mm]	Drive	€/ 100 pcs	[pcs]	[pcs]
5x30/5	9ZG530BTSPT	6,4 x 30	35	25	7,5	5	TX25		100	1.800
5x45/20	9ZG545BTSPT	6,4 x 45	35	25	7,5	20	TX25		100	1.200
5x60/35	9ZG560BTSPT	6,4 x 60	35	25	7,5	35	TX25		100	1.200

Loads, spacing and edge distance

Type	Non-cracked concrete $\geq C20/25$		Cracked concrete $\geq C20/25$		Solid brick Mz 12/ Solid brick KS 12		Hollow brick HLz 12/ KSL 12 Brick wall thickness ≥ 15 mm	
	F_{rec} [kN]	$T_{inst max}$ [Nm]	F_{rec} [kN]	$T_{inst max}$ [Nm]	F_{rec} [kN]	$T_{inst max}$ [Nm]	F_{rec} [kN]	$T_{inst max}$ [Nm]
BTS5	0,8	5	0,35	5	0,3	2	0,12	1

F_{rec} : Recommended loads incl. safety factor of 4

For anchorage depth > 25 mm the recommended tension load increases proportionally.

Concrete screw BTS6



Advantages

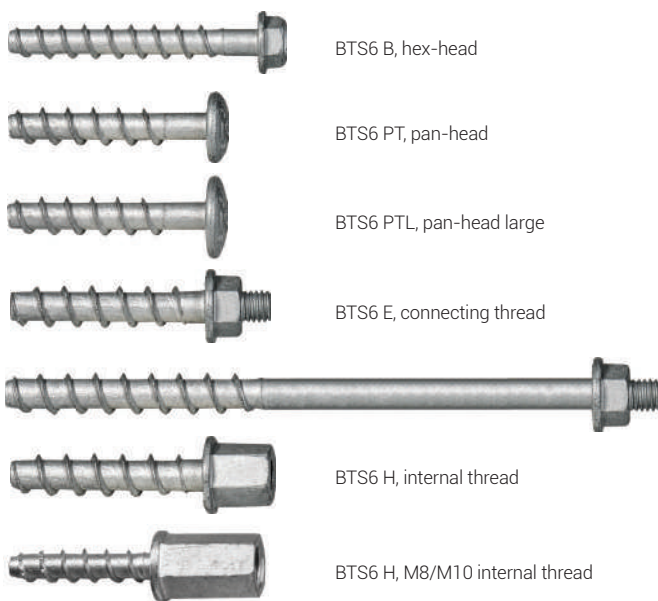

BTS6 B, hex-head

BTS6 PT, pan-head

BTS6 PTL, pan-head large

BTS6 E, connecting thread

BTS6 E long, connecting thread

BTS6 H, internal thread

BTS6 H, M8/M10 internal thread

- Very fast method for fixing rails, clamps, threaded rods aso.
- Also approved for fixing in precast pre-stressed hollow core slabs
- Easy system with a special accessory: Assembling in just two steps; drilling and fixing with the same tool
- Different heads for various applications
- Two setting depths for a higher application flexibility
- Short lengths, this means less risk of hitting rebars

Approvals and certificates



Suitable building materials

Very suitable



- Concrete
- Precast pre-stressed hollow core slabs



Suitable to a limited extent

- Dense natural stone

Mounting

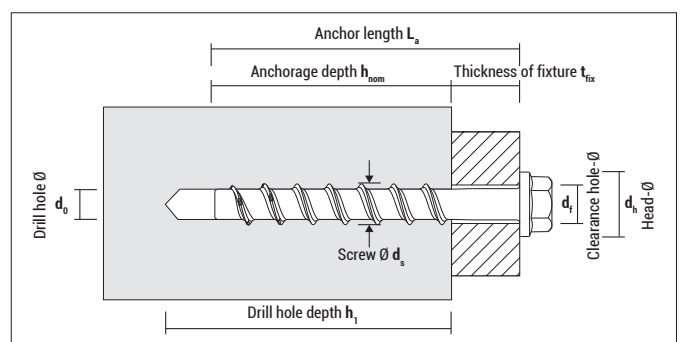
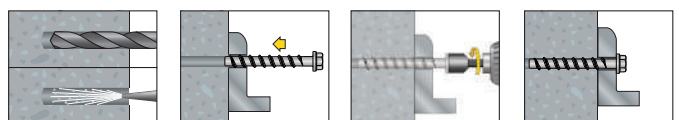

CELO



BTS6 B, zinc flake coating with hex-head with integral washer, washer-Ø SW10: 14,0 mm, SW13: 19 mm

Type d ₀ - L _a	Art-No	d _s x L _a [mm]	h ₁ ≥ [mm]	h _{nom} ≥ [mm]	d _f [mm]	t _{fix} ≤ [mm]	Recess	ETA	€ / 100 pcs	[pcs]	[pcs]
6x40/5	9ZG640BTSB	7,5 x 40	40	35	8 - 9	5	SW10	●		150	750
6x55/5	9ZG655BTSB	7,5 x 55	40 / 55	35 / 50	8 - 9	20 / 5	SW10	●		100	500



BTS6 PT, zinc flake coating with pan-head (TX 30), head-Ø: 14,5 mm

Type d ₀ - L _a	Art-No	d _s x L _a [mm]	h ₁ ≥ [mm]	h _{nom} ≥ [mm]	d _f [mm]	t _{fix} ≤ [mm]	Drive	ETA	€ / 100 pcs	[pcs]	[pcs]
6x40/5	9ZG640BTSPT	7,5 x 40	40	35	8 - 9	5	TX30	●		150	750
6x55/5	9ZG655BTSPT	7,5 x 55	40 / 55	35 / 50	8 - 9	20 / 5	TX30	●		100	500



BTS6 PTL, zinc flake coating with pan-head large (TX 30), head-Ø: 19 mm

Type d ₀ - L _a	Art-No	d _s x L _a [mm]	h ₁ ≥ [mm]	h _{nom} ≥ [mm]	d _f [mm]	t _{fix} ≤ [mm]	Drive	ETA	€ / 100 pcs	[pcs]	[pcs]
6x40/5	9ZG640BTSPTL	7,5 x 40	40	35	8 - 9	5	TX30	●		150	750
6x55/5	9ZG655BTSPTL	7,5 x 55	40 / 55	35 / 50	8 - 9	20 / 5	TX30	●		100	500



BTS6 E, zinc flake coating with connecting thread, washer-Ø: 14,0 mm

Type d ₀ - L _a	Art-No	d _s x L _a [mm]	h ₁ ≥ [mm]	h _{nom} ≥ [mm]	t _{fix} ≤ [mm]	Connecting thread	Recess	ETA	€ / 100 pcs	[pcs]	[pcs]
6x35	9ZG635M6BTSE	7,5 x 35	40	35	-	M6 (L = 6 mm)	SW10	●		150	750
6x35	9ZG635M8BTSE	7,5 x 35	40	35	-	M8 (L = 16 mm)	SW10	●		100	500



BTS6 E long, zinc flake coating with connecting thread, washer-Ø: 14,0 mm

Type d ₀ - L _a	Art-No	d _s x L _a [mm]	h ₁ ≥ [mm]	h _{nom} ≥ [mm]	t _{fix} ≤ [mm]	Connecting thread	Recess	ETA	€ / 100 pcs	[pcs]	[pcs]
6x135 M6	9ZG6135M6BTSE	7,5 x 135	40 / 55	35 / 50	100 / 85	M6 (L = 6 mm)	SW10	●		50	250
6x155 M6	9ZG6155M6BTSE	7,5 x 155	40 / 55	35 / 50	120 / 105	M6 (L = 6 mm)	SW10	●		50	250
6x175 M6	9ZG6175M6BTSE	7,5 x 175	40 / 55	35 / 50	140 / 125	M6 (L = 6 mm)	SW10	●		50	250
6x195 M6	9ZG6195M6BTSE	7,5 x 195	40 / 55	35 / 50	160 / 145	M6 (L = 6 mm)	SW10	●		50	200
6x85 M8	9ZG685M8BTSE	7,5 x 85	40 / 55	35 / 50	50 / 35	M8 (L = 16 mm)	SW10	●		50	250
6x135 M8	9ZG6135M8BTSE	7,5 x 135	40 / 55	35 / 50	100 / 85	M8 (L = 16 mm)	SW10	●		50	250
6x155 M8	9ZG6155M8BTSE	7,5 x 155	40 / 55	35 / 50	120 / 105	M8 (L = 16 mm)	SW10	●		50	250
6x175 M8	9ZG6175M8BTSE	7,5 x 175	40 / 55	35 / 50	140 / 125	M8 (L = 16 mm)	SW10	●		50	200
6x195 M8	9ZG6195M8BTSE	7,5 x 195	40 / 55	35 / 50	160 / 145	M8 (L = 16 mm)	SW10	●		50	200

The setting tool for BTS6 is not compatible.



BTS6 H, zinc flake coating with internal thread, washer-Ø: M6 and M8: 14,0 mm; M10: 17,0 mm

Type d ₀ - L _a	Art-No	d _s x L _a [mm]	h ₁ ≥ [mm]	h _{nom} ≥ [mm]	Internal thread	Recess	ETA	€ / 100 pcs	[pcs]	[pcs]
6x35 M6	9ZG635M6BTSH	7,5 x 35	40	35	M6 (L = 10 mm)	SW10	●		150	750
6x35 M8	9ZG635M8BTSH	7,5 x 35	40	35	M8 (L = 15 mm)	SW10	●		100	500
6x50 M8	9ZG650M8BTSH	7,5 x 50	40 / 55	35 / 50	M8 (L = 15 mm)	SW10	●		100	500
6x35 M10	9ZG635M10BTSH	7,5 x 35	40	35	M10 (L = 15 mm)	SW13	●		100	500

Concrete screw **BTS6**



BTS6 H M8/M10, zinc flake coating with internal thread, washer-Ø: 16,0 mm

Type d ₀ - L _a	Art-No	d _s x L _a [mm]	h ₁ ≥ [mm]	h _{nom} ≥ [mm]	Internal thread	Recess	ETA	€/ 100 pcs	[pcs]	[pcs]
6x35 M8/M10	9ZG635M810BTSH	7,5 x 35	40	35	M8/M10 (L = 18 mm)	SW13	●		100	500
6x50 M8/M10	9ZG650M810BTSH	7,5 x 50	40 / 55	35 / 50	M8/M10 (L = 18 mm)	SW13	●		100	500

Accessories
Concrete screw **BTS6**



SDS special drill bit Ø6 mm
Usable drill length 105 mm



Special adapter
Put over the drill bit and the socket wrench



Socket wrench
for quick mounting of
all BTS6 with hex-head

Accessories for concrete screw **BTS6**

Type	Art-No	d ₀ [mm]	L [mm]	Recess	€/ 1 pc	[pc]	[pcs]
Special drill bit SDS 6 mm	6115SDSBTS6	6	175	SDS plus		1	-
Special adapter	9ATRBCA	13	145	2x hex-head		1	-
Socket wrench 10 (SW10) *	910LLTRBCA	18	65	hexagon		1	-
Socket wrench 13 (SW13) *	913M8LLTRB	20	65	hexagon		1	-

* Not compatible with BTS6E long.

Loads, spacing and edge distance for multiple use for non-structural applications in **cracked concrete** C20/25-C50/60

Type	Permissible load in any direction ^{1,2)}		Permissible bending moment ²⁾ M _{per} [Nm]	Spacing		Edge distance		Min. thickness of structural part h _{min} [mm]	Max. torque of the impact wrench T _{imp} [Nm]
	h _{nom} 35 mm F _{per} [kN]	h _{nom} 50 mm F _{per} [kN]		S _{cr} [mm]	S _{min} [mm]	C _{cr} [mm]	C _{min} [mm]		
BTS 6x35 BTS 6x40	0,85	-	5,7	160	40	80	40	100	150
BTS 6x50 BTS 6x55	0,85	1,90	5,7	160	40	80	40	100	150

¹⁾ Permissible loads without influence of spacing and edge distance.

²⁾ Load figures include the resistances' partial safety factors as per ETA assessment and a partial safety factor on the action of γ_F = 1,4
If underrun the char. spacing or edge distance (C_{cr} or S_{cr}) the loads must be reduced. h_{min}, S_{min} and C_{min} must be observed.

Loads, spacing and edge distance for multiple use for non-structural applications in **precast pre-stressed hollow core slabs** C45/55

Type	Permissible load in any direction ^{1,2)} h _{nom} 35 mm F _{per} [kN]	Permissible bending moment ²⁾ M _{per} [Nm]	Spacing		Edge distance	
			S _{cr} [mm]	S _{min} [mm]	C _{cr} [mm]	C _{min} [mm]
BTS 6	1,02	5,7	200	200	150	150

¹⁾ Permissible loads without influence of spacing and edge distance.

²⁾ Load figures include the resistances' partial safety factors as per ETA assessment and a partial safety factor on the action of γ_F = 1,4
If underrun the char. spacing or edge distance (C_{cr} or S_{cr}) the loads must be reduced. h_{min}, S_{min} and C_{min} must be observed.

Loads, spacing and edge distance for multiple use for non-structural applications in **precast pre-stressed hollow core slabs**:
Concrete ≥ C45/55 / thickness of bottom flange ≥ 35 mm

Concrete screw BTS



Advantages



BTS B, hex-head
- zinc flake coating
- stainless steel A4



BTS ST, countersunk head
- zinc plated
- stainless steel A4

- Approved for cracked and non-cracked concrete
- High loads combined with an easy application (the use of a suitable impact wrench is necessary)
- Variable, because of three setting depths
- The BTS may be adjusted
- Big range, also in stainless steel and different head shapes available
- The BTS is also ideal for temporary fixings as it can be removed completely
- Zinc flake coating (ZnAl) for improved corrosion resistance and higher application security

Suitable building materials

Very suitable



- Concrete



Suitable to a limited extent

- Dense natural stone

Approvals and certificates

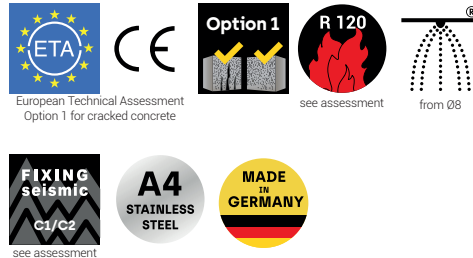

Mounting

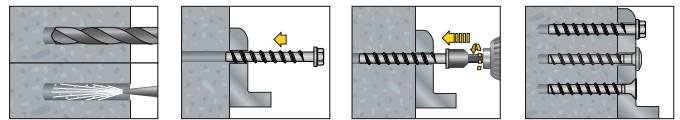

BTS 8: Impact wrench max. 300 Nm
BTS 10: Impact wrench max. 400 Nm
BTS 14: Impact wrench max. 650 Nm

The BTS may be adjusted up to two times for max. 10 mm in order to use shims - for details see assessment.

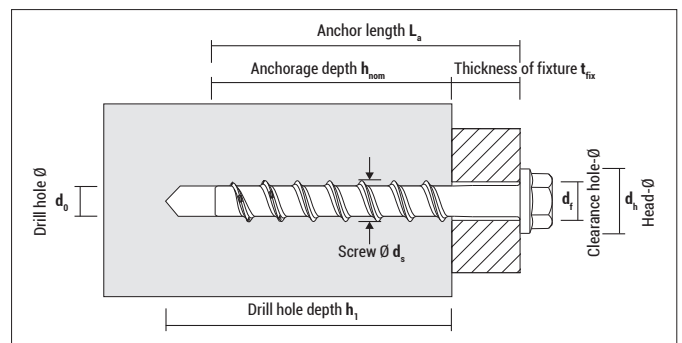

Concrete screw BTS



BTS B, zinc flake coating with hex-head and integral washer (washer-Ø: BTS 8: Ø 16,2 mm; BTS 10: Ø 20,0 mm; BTS 14: Ø 30,0 mm)

Type $d_o - L_a$	Art-No	$d_{s \times L_a}$ [mm]	$h_1 \geq$ [mm]	$h_{nom} \geq$ [mm]	$t_{fix} \leq$ [mm]	d_f [mm]	Recess		€/100 pcs	 [pcs]	 [pcs]
8x50/-	9ZG850BTSB	10,6x50	55/-/-	45/-/-	5/-/-	11-12	SW 13	●		50	250
8x70/5	9ZG870BTSB	10,6x70	55/65/75	45/55/65	25/15/5	11-12	SW 13	●		50	250
8x80/15	9ZG880BTSB	10,6x80	55/65/75	45/55/65	35/25/15	11-12	SW 13	●		50	250
8x90/25	9ZG890BTSB	10,6x90	55/65/75	45/55/65	45/35/25	11-12	SW 13	●		50	250
8x100/35	9ZG8100BTSB	10,6x100	55/65/75	45/55/65	55/45/35	11-12	SW 13	●		50	250
8x120/55	9ZG8120BTSB	10,6x120	55/65/75	45/55/65	75/65/55	11-12	SW 13	●		50	250
10x60/-	9ZG1060BTSB	12,6x60	65/-/-	55/-/-	5/-/-	13-14	SW 15	●		50	250
10x70/-	9ZG1070BTSB	12,6x70	65/-/-	55/-/-	15/-/-	13-14	SW 15	●		40	200
10x80/-	9ZG1080BTSB	12,6x80	65/85/-	55/57/-	25/5/-	13-14	SW 15	●		40	200
10x90/5	9ZG1090BTSB	12,6x90	65/85/95	55/75/85	35/15/5	13-14	SW 15	●		40	200
10x100/15	9ZG10100BTSB	12,6x100	65/85/95	55/75/85	45/25/15	13-14	SW 15	●		40	200
10x120/35	9ZG10120BTSB	12,6x120	65/85/95	55/75/85	65/45/35	13-14	SW 15	●		40	200
10x140/55	9ZG10140BTSB	12,6x140	65/85/95	55/75/85	85/65/55	13-14	SW 15	●		30	150
10x160/75	9ZG10160BTSB	12,6x160	65/85/95	55/75/85	105/85/75	13-14	SW 15	●		30	150
14x80/-	9ZG1480BTSB	16,6x80	85/-/-	75/-/-	5/-/-	18	SW 21	●		20	100
14x110/-	9ZG14110BTSB	16,6x110	85/110/-	75/100/-	35/10/-	18	SW 21	●		20	100



BTS B, zinc flake coating with hex-head and integral washer (washer-Ø: BTS 10: Ø 20,0 mm)

with large washer according to ISO 7094 (DIN 440) for woodworking (included in packing, outer Ø = 44 mm)

Type $d_o - L_a$	Art-No	$d_{s \times L_a}$ [mm]	$h_1 \geq$ [mm]	$h_{nom} \geq$ [mm]	$t_{fix} \leq$ [mm]	d_f [mm]	Recess		€/100 pcs	 [pcs]	 [pcs]
10x180/95	9ZG10180BTSB	12,6x180	65/85/95	55/75/85	125/105/95	13-14	SW 15	●		20	100
10x200/115	9ZG10200BTSB	12,6x200	65/85/95	55/75/85	145/125/115	13-14	SW 15	●		20	80
10x240/155	9ZG10240BTSB	12,6x240	65/85/95	55/75/85	185/165/155	13-14	SW 15	●		20	80
10x280/195	9ZG10280BTSB	12,6x280	65/85/95	55/75/85	225/205/195	13-14	SW 15	●		20	80



BTS B, stainless steel A4 with hex-head and integral washer (washer-Ø: BTS 8: Ø 16,2 mm; BTS 10: Ø 20,0 mm)

A4
STAINLESS
STEEL

Type $d_o - L_a$	Art-No	$d_{s \times L_a}$ [mm]	$h_1 \geq$ [mm]	$h_{nom} \geq$ [mm]	$t_{fix} \leq$ [mm]	d_f [mm]	Recess		€/100 pcs	 [pcs]	 [pcs]
8x80/15	9X880BTSB	10,5x80	55/65/75	45/55/65	35/25/15	11-12	SW 13	●		50	250
10x90/5	9X1090BTSB	12,5x90	65/85/95	55/75/85	35/15/5	13-14	SW 15	●		40	200
10x100/15	9X10100BTSB	12,5x100	65/85/95	55/75/85	45/25/15	13-14	SW 15	●		40	200



BTS ST zinc plated with countersunk head (Head-Ø: BTS ST 8: Ø 19,5 mm; BTS ST 10: Ø 21,5 mm)

Type $d_o - L_a$	Art-No	$d_{s \times L_a}$ [mm]	$h_1 \geq$ [mm]	$h_{nom} \geq$ [mm]	$t_{fix} \leq$ [mm]	d_f [mm]	Drive		€/100 pcs	 [pcs]	 [pcs]
8x80/15	9880BTSST	10,6x80	55/65/75	45/55/65	35/25/15	11-12	TX 40	●		50	250
10x90/5	91090BTSST	12,6x90	65/85/95	55/75/85	35/15/5	13-14	TX 50	●		40	200

Concrete screw BTS

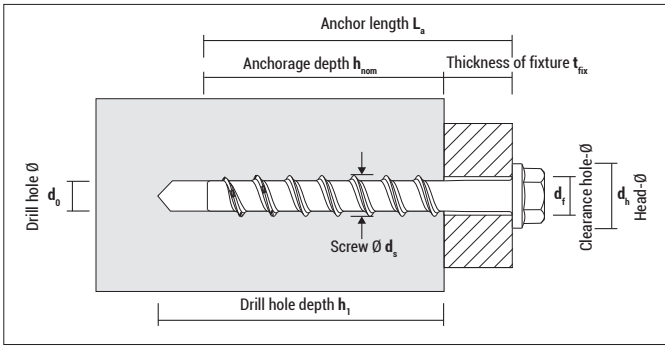

BTS ST stainless steel A4 with countersunk head (Head-Ø: BTS ST 8: Ø 19,5 mm; BTS ST 10: Ø 21,5 mm)



Type $d_0 - L_a$	Art-No	$d_s \times L_a$ [mm]	$h_1 \geq$ [mm]	$h_{nom} \geq$ [mm]	$t_{fix} \leq$ [mm]	d_f [mm]	Drive	ETA	€/100 pcs	[pcs]	[pcs]
8x80/15	9X880BTSST	10,5x80	55 / 65 / 75	45 / 55 / 65	35 / 25 / 15	11 - 12	TX 40	●		50	250
10x90/5	9X1090BTSST	12,5x90	65 / 85 / 95	55 / 75 / 85	35 / 15 / 5	13 - 14	TX 50	●		40	200

Loads and installation parameters (values are valid for BTS in carbon steel and stainless steel)

		BTS 8				BTS 10				BTS 14		
		ZnAl	A4	ZnAl	A4	ZnAl	A4	ZnAl	A4	ZnAl	A4	
Drill hole Ø	d_0 [mm]	8				10				14		
Thread Ø	d_s [mm]	10,6	10,5	10,5	10,6	10,5	12,6	12,5	12,5	12,6	12,5	16,6
Ø of clearance hole in fixture	$d_f \leq$ [mm]	12				14				18		
Anchorage depth	h_{nom} [mm]	45	55	65			55	75	85	75	100	115

Permissible tension load in cracked concrete^{1), 2), 3)}

C20/25	N_{per} [kN]	2,4	1,4	4,3	2,6	5,7	3,8	4,3	2,9	7,6	6,2	9,2	8,1	7,2	11,5	14,5
--------	----------------	-----	-----	-----	-----	-----	-----	-----	-----	-----	-----	-----	-----	-----	------	------

Permissible tension load in non-cracked concrete^{1), 2), 3)}

C20/25	N_{per} [kN]	3,6	4,2	5,7	5,7	7,6	8,0	5,7	5,2	9,5	9,0	12,4	11,9	10,4	16,5	20,7
--------	----------------	-----	-----	-----	-----	-----	-----	-----	-----	-----	-----	------	------	------	------	------

Permissible shear load in cracked concrete

C20/25	V_{per} [kN]	3,4	6,2	4,6	7,7	6,2	9,7	4,6	10,4	15,2	17,6	18,4	19,4	7,2	23,0	28,9
--------	----------------	-----	-----	-----	-----	-----	-----	-----	------	------	------	------	------	-----	------	------

Permissible shear load in non-cracked concrete

C20/25	V_{per} [kN]	4,9	7,7	6,6	7,7	8,8	9,7	6,6	12,9	19,4	19,4	19,4	19,4	10,4	32,0	32,0
--------	----------------	-----	-----	-----	-----	-----	-----	-----	------	------	------	------	------	------	------	------

Permissible bending moment	M_{per} [Nm]	15	14,9	15	14,9	15	14,9	32				106		
----------------------------	----------------	----	------	----	------	----	------	----	--	--	--	-----	--	--

Spacing and edge distance

Spacing ⁴⁾	$S_{cr,N}$ [mm]	105	96	129	123	156	147	129	120	180	171	204	255	174	237	276
Edge distance ⁴⁾	$C_{cr,N}$ [mm]	53	48	65	62	78	74	65	60	90	86	102	98	87	119	138
Minimum spacing ⁴⁾	S_{min} [mm]	40	35	50	35	50	35	50	40	50	40	50	40	50	70	70
Min. edge distance ⁴⁾	C_{min} [mm]	40	35	50	35	50	35	50	40	50	40	50	40	50	70	70
Min. thickness of structural part	h_{min} [mm]	100	80	100		120		100		130		130		130	150	170

Max. installation torque for impact wrench	$T_{imp} \leq$ [Nm]	300				400	450	400	450	400	450	650		
--	---------------------	-----	--	--	--	-----	-----	-----	-----	-----	-----	-----	--	--

¹⁾ Permissible loads for single anchor without influence of spacing and edge distance.
²⁾ Load figures include the resistances' partial safety factors as per ETA assessment and a partial factor on the action of $\gamma_f = 1,4$.
³⁾ For higher concrete strengths up to C50/60 the values increase by max. 55% compared with C20/25.
⁴⁾ If underrun the char. spacing or edge distance (C_{cr} or S_{cr}) the loads must be reduced. h_{min} , S_{min} and C_{min} must be observed.

Concrete screw BTS M



Advantages



BTS M 14-80, zinc plated



BTS M 14-130, zinc plated



BTS M 14-80, zinc flake coating



BTS M 14-130, zinc flake coating



- Special concrete screw: Approved for temporary construction site facilities such as inclined supports, guardrails and scaffoldings
- The approval also regulates the use in fresh concrete ($\geq 10 \text{ N} / \text{mm}^2$), in cracked and non-cracked concrete and for outdoor applications
- Reusable - for details see approval
- Including test sleeve in each box to check the reusability

Suitable building materials

Very suitable



- Concrete



Approvals and certificates



Mounting

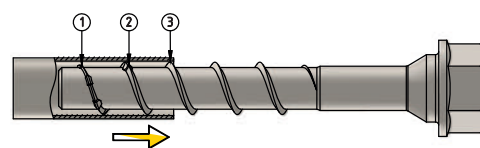
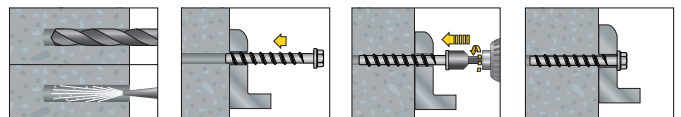

The BTS M may only be reused if max. 3 threads can penetrate into the test sleeve.

Concrete screw BTS M

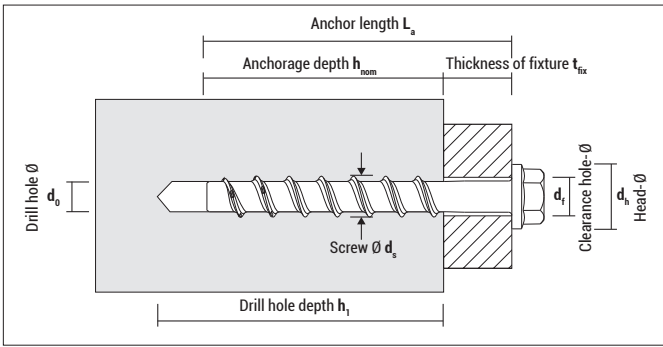

BTS M, zinc plated 1 test sleeve per box included (washer-Ø: 14-80: 28 mm, 14-130: 32 mm)

Type $d_0 - L_a$	Art-No	$d_s \times L_a$ [mm]	$h_1 \geq$ [mm]	$h_{nom} \geq$ [mm]	d_f [mm]	$t_{fix} \leq$ [mm]	Recess	€/ 100 pcs	[pcs]	[pcs]
14x80/5	91480BTSMB	16,6 x 80	85	75	18	5	SW 22		20	100
14x130/15	914130BTSMB	16,6 x 130	85/100/125	75/90/115	18	55/40/15	SW 24		15	75



BTS M, zinc flake coating 1 test sleeve per box included (washer-Ø: 14-80: 28 mm, 14-130: 32 mm)

Type $d_0 - L_a$	Art-No	$d_s \times L_a$ [mm]	$h_1 \geq$ [mm]	$h_{nom} \geq$ [mm]	d_f [mm]	$t_{fix} \leq$ [mm]	Recess	€/ 100 pcs	[pcs]	[pcs]
14x80/5	9ZG1480BTSMB	16,6 x 80	85	75	18	5	SW 21		20	100
14x130/15	9ZG14130BTSMB	16,6 x 130	85/100/125	75/90/115	18	55/40/15	SW 24		15	75

Loads and installation parameters

			BTS M 14-80/5		BTS M 14-130/15		
Drill hole Ø	d_0	[mm]	14		14		
Thread Ø	d_s	[mm]	16,6		16,6		
Ø of clearance hole in fixture	$d_f \leq$	[mm]	18		18		
Anchorage depth	h_{nom}	[mm]	75	75	90	115	
Min. thickness of structural part	h_{min}	[mm]	150	150	195	200	225

Permissible load in cracked and non-cracked concrete^{1, 2)}

C8/10	F_{per}	[kN]	4,0	4,0	8,0	10,0	11,3
C12/15	F_{per}	[kN]	4,7	4,7	8,7	12,0	14,0
C16/20	F_{per}	[kN]	5,3	5,3	9,3	13,3	16,0

Spacing and edge distance

Minimum spacing	s_{min}	[mm]	320	320	390	500	500
Min. edge distance in load direction	$c_{1,min}$	[mm]	105	105	130	165	165
Min. edge distance vertical to load direction	$c_{2,min}$	[mm]	160	160	195	250	250
Max. installation torque for impact wrench (BTS M, zinc flake coating)	$T_{imp} \leq$	[Nm]	650		650		
Max. installation torque for impact wrench (BTS M, zinc plated)	$T_{imp} \leq$	[Nm]	450		450		

¹⁾ Permissible load in all directions for single anchor without influence of spacing and edge distance

²⁾ Load figures include the resistances' partial safety factors as per ETA assessment and a partial factor on the action of $\gamma_F = 1,5$.

h_{min} , s_{min} and c_{min} must be observed.

Heavy-duty anchor SLA



Advantages



SLA C with countersunk head



SLA S with hex-head screw



SLA B with bolt and hexagon nut

- Torque controlled heavy-duty anchor, designed for heaviest loads
- Available with various heads
- The integrated plastic ring prevents twisting of the anchor and allows to overcome gaps between the attached part and the concrete surface
- Anchorage depth marking for quick installation

Suitable building materials

Very suitable



- Concrete



SLA C, zinc plated with countersunk screw; steel quality 8.8

Type	Art-No	d_0 [mm]	$h_1 \geq$ [mm]	$h_{ef} \geq$ [mm]	L_a [mm]	$t_{fix} \leq$ [mm]	Thread		€/ 100 pcs	[pcs]	[pcs]
C 12x80/16	91280SLAC	12	85	59	80	16	M8	●		30	150
C 12x90/26	91290SLAC	12	85	59	90	26	M8	●		30	150
C 12x120/56	912120SLAC	12	85	59	120	56	M8	●		25	125
C 15x90/17	91590SLAC	15	95	67	90	17	M10	●		20	100
C 15x100/27	915100SLAC	15	95	67	100	27	M10	●		15	75

Approvals and certificates



European Technical Assessment
Option 1 for cracked concrete



see assessment



Mounting

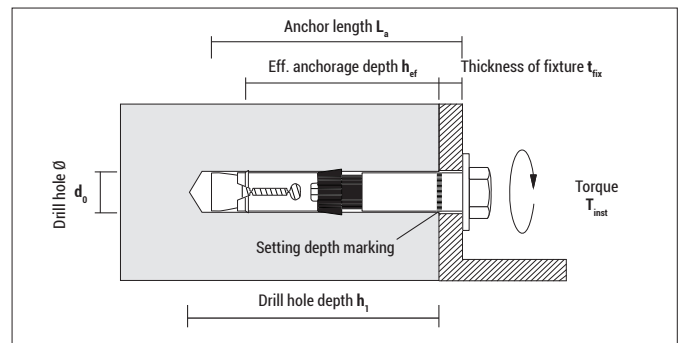
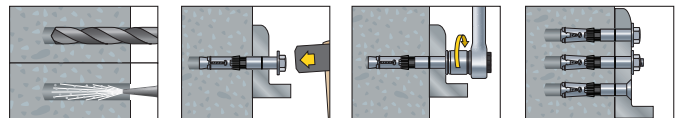

Heavy-duty anchor SLA



SLA S, zinc plated with hex-head screw; steel quality 8.8

Type	Art-No	d ₀ [mm]	h ₁ ≥ [mm]	h _{ef} ≥ [mm]	L _a [mm]	t _{fix} ≤ [mm]	Thread	ETA	€/100 pcs	[pcs]	[pcs]
S 12x80/10	91280SLAS	12	85	59	80	10	M8	●		30	150
S 12x90/20	91290SLAS	12	85	59	90	20	M8	●		30	150
S 12x120/50	912120SLAS	12	85	59	120	50	M8	●		25	125
S 15x90/10	91590SLAS	15	95	67	90	10	M10	●		20	100
S 15x100/20	915100SLAS	15	95	67	100	20	M10	●		15	75
S 15x130/50	915130SLAS	15	95	67	130	50	M10	●		15	75
S 18x110/10	918110SLAS	18	115	88	110	10	M12	●		10	50
S 18x125/25	918125SLAS	18	115	88	125	25	M12	●		10	50
S 18x150/50	918150SLAS	18	115	88	150	50	M12	●		5	25
S 24x125/10	924125SLAS	24	130	99	125	10	M16	●		5	25
S 24x140/25	924140SLAS	24	130	99	140	25	M16	●		5	25
S 24x165/50	924165SLAS	24	130	99	165	50	M16	●		4	20



SLA B, zinc plated with bolt and hexagon nut; steel quality 8.8

Type	Art-No	d ₀ [mm]	h ₁ ≥ [mm]	h _{ef} ≥ [mm]	L _a [mm]	t _{fix} ≤ [mm]	Thread	ETA	€/100 pcs	[pcs]	[pcs]
B 12x80/10	91280SLAB	12	85	59	80	10	M8	●		30	150
B 12x90/20	91290SLAB	12	85	59	90	20	M8	●		30	150
B 12x120/50	912120SLAB	12	85	59	120	50	M8	●		25	125
B 15x90/10	91590SLAB	15	95	67	90	10	M10	●		20	100
B 15x100/20	915100SLAB	15	95	67	100	20	M10	●		15	75
B 15x130/50	915130SLAB	15	95	67	130	50	M10	●		15	75
B 15x180/100	915180SLAB	15	115	67	180	100	M10	●		10	50
B 18x110/10	918110SLAB	18	115	88	110	10	M12	●		10	50
B 18x125/25	918125SLAB	18	115	88	125	25	M12	●		10	50
B 18x200/100	918200SLAB	18	115	88	200	100	M12	●		5	25
B 24x125/10	924125SLAB	24	130	99	125	10	M16	●		5	25
B 24x140/25	924140SLAB	24	130	99	140	25	M16	●		5	25
B 24x165/50	924165SLAB	24	130	99	165	50	M16	●		4	20
B 24x215/100	924215SLAB	24	130	99	215	100	M16	●		4	-

Installation parameters

SLA S/B/C Size		M8	M10	M12	M16
Torque	T _{inst} [Nm]	20	45	80	150
SLA S/B width across flats	SW [mm]	13	17	19	24
SLA C internal hexagon	[mm]	6	8	-	-
Ø of clearance hole in fixture	d _f [mm]	14	17	20	26

Loads, spacing and edge distance

Type	Size	Cracked concrete ^{1),2)} C20/25		Non-cracked concrete ^{1),2)} C20/25		Permissible bending moment M _{per} [Nm]	Spacing		Edge distance		Min. thickness of structural part h _{min} [mm]
		Tension N _{per} [kN]	Shear V _{per} [kN]	Tension N _{per} [kN]	Shear V _{per} [kN]		S _{cr} [mm]	S _{min} [mm]	C _{cr} [mm]	C _{min} [mm]	
SLA 12	M8	5,7	7,8	10,9	10,9	17	177	60	89	60	120
SLA 15	M10	7,6	18,8	13,2	24,0	34	201	70	101	70	140
SLA 18	M12	11,9	28,3	19,8	28,6	60	264	80	132	80	180
SLA 24	M16	16,9	33,8	23,6	47,4	152	297	100	149	100	200

¹⁾ Permissible loads for single anchor without influence of spacing and edge distance.

²⁾ Load values include the resistances' partial safety factors as per ETA assessment and a partial safety factor on the action of γ_F = 1,4.

For higher concrete strengths the values increase N_{per} by max 55% (N_{per,C50/60} = 1,55 x N_{per,C20/25})

If underrun the char. spacing or edge distance (C_{cr} or S_{cr}) the loads must be reduced. h_{min}, S_{min} and C_{min} must be observed.

Forced expansion anchor

ZA



Advantages



ZA Type S with hex-head screw



ZA Type B with bolt and hexagon nut

- Suitable for heavy fixings in non-cracked concrete
- ZA 12 (M8) with ETA assessment
- Force controlled spreading of the sleeve when the screw or nut is tightened
- Easy installation as the plug sleeve spreads with a low force
- Low setting depth
- The groove allows to overcome gaps between the attached part and the concrete surface

Approvals and certificates



Suitable building materials

Very suitable



- Concrete



Mounting

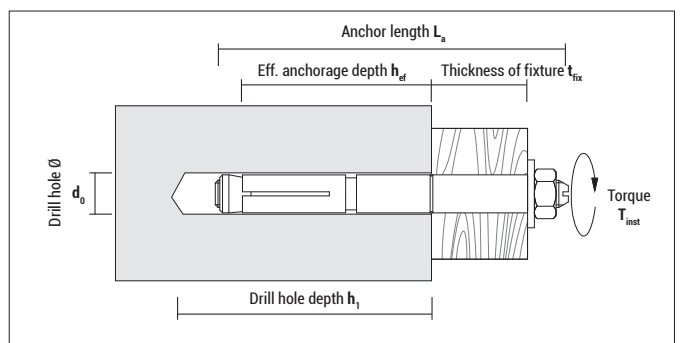
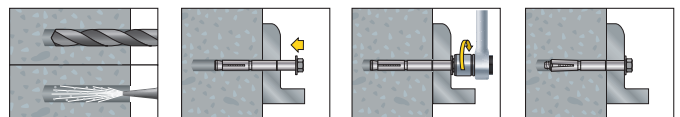

Forced expansion anchor ZA



ZA Type S, zinc plated with hex-head screw, steel quality 8.8

Type	Art-No	d ₀ [mm]	h ₁ ≥ [mm]	h _{ef} ≥ [mm]	L _a [mm]	t _{fix} ≤ [mm]	Thread	ETA	€/100 pcs	pcs	pcs
S 10x55/10	91055ZAS	10	55	40	55	10	M6	—		100	—
S 12x60/10	91260ZAS	12	55	40	60	10	M8	●		50	—
S 12x75/25	91275ZAS	12	55	40	75	25	M8	●		50	—
S 12x85/35	91280ZAS	12	55	40	85	35	M8	●		50	—
S 12x100/50	912100ZAS	12	55	40	100	50	M8	●		50	—
S 14x70/10	91470ZAS	14	70	50	70	10	M10	—		50	—
S 14x85/25	91485ZAS	14	70	50	85	25	M10	—		50	—
S 14x110/50	914110ZAS	14	70	50	110	50	M10	—		25	—
S 18x90/10 ¹⁾	91890ZAS	18	80	60	90	10	M12	—		25	—
S 18x100/25 ¹⁾	918100ZAS	18	80	60	100	25	M12	—		25	—
S 18x130/50 ¹⁾	918130ZAS	18	80	60	130	50	M12	—		25	—

¹⁾ discontinued article, delivery while stocks last



ZA Type B, zinc plated with bolt and hexagon nut, steel quality 8.8

Type	Art-No	d ₀ [mm]	h ₁ ≥ [mm]	h _{ef} ≥ [mm]	L _a [mm]	t _{fix} ≤ [mm]	Thread	ETA	€/100 pcs	pcs	pcs
B 12x70/10	91270ZAB	12	55	40	70	10	M8	●		50	—
B 12x85/25	91285ZAB	12	55	40	85	25	M8	●		50	—
B 12x110/50	912110ZAB	12	55	40	110	50	M8	●		50	—
B 12x160/100	912160ZAB	12	55	40	160	100	M8	●		50	—
B 14x120/50 ¹⁾	914120ZAB	14	70	50	120	50	M10	—		25	—
B 18x96/10 ¹⁾	91896ZAB	18	80	60	96	10	M12	—		25	—

¹⁾ discontinued article, delivery while stocks last

Installation parameters

ZA S/B Size	M6	M8	M10	M12	
Torque	T _{inst} [Nm]	8,5	20	40	70
Width across flats	SW [mm]	10	13	17	19
Ø of clearance hole in fixture	d _f [mm]	12	14	16	22

Loads, spacing and edge distance for ZA 12 according to ETA assessment in non-cracked concrete

Type	Size	Non-cracked concrete ^{1) 2)}		Permissible bending moment M _{per} [Nm]	Spacing		Edge distance		Min. Thickness of structural part h _{min} [mm]
		C20/25 N _{per} [kN]	V _{per} [kN]		S _{cr} [mm]	S _{min} [mm]	C _{cr} [mm]	C _{min} [mm]	
ZA 12	M8	5,7	6,1	17,1	120	90	60	60	120

¹⁾ Permissible loads for single anchor without influence of spacing and edge distance. (C > 10 × h_{ef})

²⁾ Load values include the resistances' partial safety factors as per ETA assessment and a partial safety factor on the action of v_F = 1,4.

For higher concrete strengths the values increase N_{per} by max 55 % (N_{per, C50/60} = 1,55 × N_{per, C20/25})

If underrun the char. spacing or edge distance (C_{cr} or S_{cr}) the loads must be reduced. h_{min}, S_{min} and C_{min} must be observed.

Loads, spacing and edge distance according to former DIBt approval in non-cracked concrete

Type	Size	Non-cracked concrete			Reduction factor ¹⁾	Bending moment M _{empf} [Nm]	Spacing S [mm]	Edge distance ²⁾ C [mm]	Min. thickness of structural part h _{min} [mm]
		C12/15 F _{rec} [kN]	C20/25 F _{rec} [kN]	C30/37 F _{rec} [kN]					
ZA 10	M6	1,5	2,1	2,5	0,70	7,0	260	130	110
ZA 14	M10	3,5	5,0	5,9	0,80	34,2	440	220	150
ZA 18	M12	5,2	7,4	8,7	0,90	60,0	500	250	180

F_{rec}: Recommended loads in all directions in non-cracked concrete.

¹⁾ Reduction factor for the permissible load, if a reinforcement steel with an axis clearance of less than 15 cm exists in the area of the anchorage

²⁾ Edge distance may be reduced by a factor of 0,72, if anchor is inserted at the edge of the structural member, instead of the corner

Sleeve anchor Dnbolt



Advantages

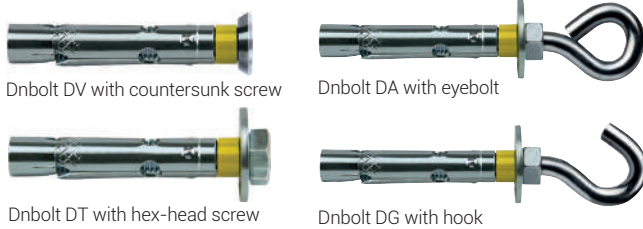

- Allrounder for many day-to-day fastenings for medium loads up to 1.000 kg
- Dnbolt DT and DV with ETA assessment for non-cracked concrete
- Anti-rotation cone with ribs for secure expansion
- Due to the special sleeve construction, the fixture can be pressed flush to the concrete surface
- Chamfered sleeve guarantees perfect sliding on the cone and thus a secure fixing
- Load capacity tested by an independent institute (Applus+)

Approvals and certificates

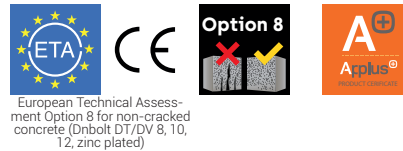

Suitable building materials

Very suitable



- Concrete



Suitable to a limited extent



- Dense natural stone
- Solid brick

Mounting

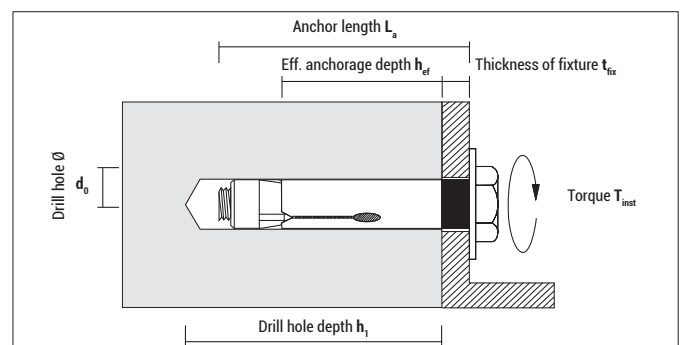
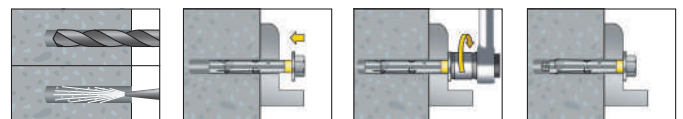

Dnbolt DV, zinc plated with countersunk screw; Head-Ø 16 mm

Type	Art-No	d ₀ [mm]	h ₁ ≥ [mm]	h _{ef} ≥ [mm]	L _a [mm]	t _{fix} ≤ [mm]	Thread	Recess	ETA	€/ 100 pcs	[pcs]	[pcs]
10x60/10	91060DV	10	55	37	60	10	M8	TX 40	●		100	400
10x80/30	91080DV	10	55	37	80	30	M8	TX 40	●		100	400



Dnbolt DT, zinc plated with hex-head screw

Type	Art-No	d ₀ [mm]	h ₁ ≥ [mm]	h _{ef} ≥ [mm]	L _a [mm]	t _{fix} ≤ [mm]	Thread	Recess	ETA	€/100 pcs	[pcs]	[pcs]
8 x 45/5	9845DT	8	45	30	45	5	M6	SW 10	●		250	1.000
8 x 60/20	9860DT	8	45	30	60	20	M6	SW 10	●		200	800
10 x 60/10	91060DT	10	55	37	60	10	M8	SW 13	●		100	400
10 x 80/30	91080DT	10	55	37	80	30	M8	SW 13	●		100	400
12 x 70/10	91270DT	12	65	43	70	10	M10	SW 17	●		50	200
12 x 100/40	912100DT	12	65	43	100	40	M10	SW 17	●		50	200
14 x 70/10	91470DT	14	65	43	70	10	M10	SW 17	–		50	200
14 x 100/40	914100DT	14	65	43	100	40	M10	SW 17	–		50	200
16 x 80/10	91680DT	16	75	55	80	10	M12	SW 19	–		40	160
16 x 110/40	916110DT	16	75	55	110	40	M12	SW 19	–		25	100
20 x 110/30	921110DT	20	85	65	110	30	M16	SW 24	–		10	40
25 x 130/30	926130DT	25	105	80	130	30	M20	SW 30	–		8	32



Dnbolt DA, zinc plated with eyebolt

Type	Art-No	d ₀ [mm]	h ₁ ≥ [mm]	h _{ef} ≥ [mm]	L _a [mm]	t _{fix} ≤ [mm]	Thread	Recess	€/100 pcs	[pcs]	[pcs]
8 x 45/5	9845DA	8	45	30	45	5	M6	SW 10		100	400
10 x 60/10	91060DA	10	55	37	60	10	M8	SW 13		50	200



Dnbolt DG, zinc plated with hook

Type	Art-No	d ₀ [mm]	h ₁ ≥ [mm]	h _{ef} ≥ [mm]	L _a [mm]	t _{fix} ≤ [mm]	Thread	Recess	€/100 pcs	[pcs]	[pcs]
8 x 45/5	9845DG	8	45	30	45	5	M6	SW 10		100	400
10 x 60/10	91060DG	10	55	37	60	10	M8	SW 13		50	200

Loads, spacing and edge distance for Dnbolt DT/DV 8, 10, 12 according to ETA assessment for non-cracked concrete

Type	Size	Torque T _{inst} [Nm]	Non-cracked concrete ¹⁾²⁾ ≥ C20/25			Permissible bending moment		Spacing		Edge distance		Min. thickness of structural part h _{min} [mm]
			Tension N _{per} [kN]	Steel 6.8 Shear V _{per} [kN]	Steel 8.8* Shear V _{per} [kN]	Steel 6.8 M _{per} [Nm]	Steel 8.8* M _{per} [Nm]	S _{cr} [mm]	S _{min} [mm]	C _{cr} [mm]	C _{min} [mm]	
Dnbolt 8	M6	10	2,9	3,4	4,0	5,3	7,0	90	40	45	40	100
Dnbolt 10	M8	15	3,6	5,4	5,4	12,9	17,1	111	50	56	50	100
Dnbolt 12	M10	30	4,8	6,8	6,8	25,7	34,2	129	60	65	60	110

¹⁾ Permissible loads for single anchor without influence of spacing and edge distance. (C > 10 x h_{ef})

²⁾ Load values include the resistances' partial safety factors as per ETA assessment and a partial safety factor on the action of γ_F = 1,4.

If underrun the char. spacing or edge distance (C_{cr} or S_{cr}) the loads must be reduced. h_{min}, S_{min} and C_{min} must be observed.

* Dnbolt in steel 8.8 only on request

Recommended loads for Dnbolt DT and DV in non-cracked concrete C20/C25 for not approved sizes

Type	Size	Torque T _{inst} [Nm]	Drill hole Ø [mm]	Zinc plated, Steel quality 6.8		Stainless steel A2	
				Tension load N _{rec} [kN]	Shear load V _{rec} [kN]	Tension load N _{rec} [kN]	Shear load V _{rec} [kN]
Dnbolt 8	M6	10	8	–	–	1,8	2,0
Dnbolt 10	M8	15	10	–	–	2,0	3,2
Dnbolt 12	M10	30	12	–	–	3,4	4,8
Dnbolt 14	M10	30	14	6,2	8,6	3,5	5,6
Dnbolt 16	M12	65	16	7,5	12,0	4,8	8,5
Dnbolt 20	M16	150	20	8,9	26,0	–	–
Dnbolt 25	M20	300	25	10,6	28,8	–	–

F_{rec}: Recommended loads in all directions incl. safety factors





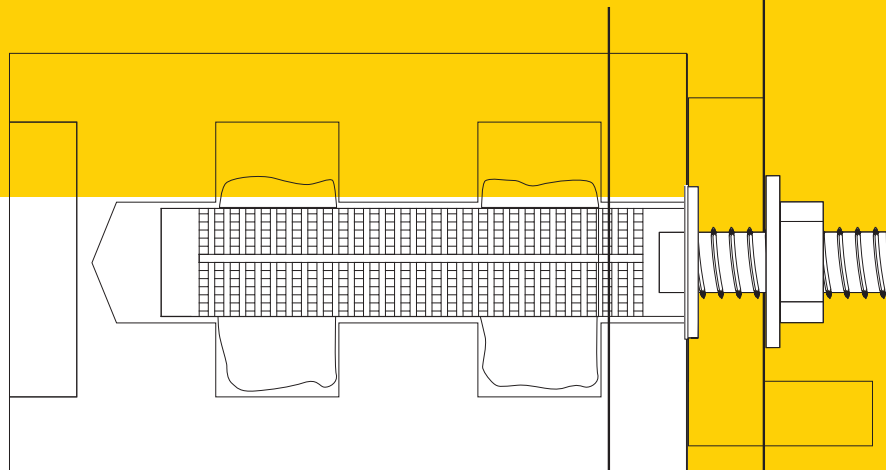

Recommended loads for Dnbolt DA and DG in non-cracked concrete C20/C25 without approval

Type	Size	Drill hole Ø [mm]	DA with eyebolt F _{rec} [kN]	DG with hook F _{rec} [kN]
Dnbolt 8	M6	8	0,6	0,6
Dnbolt 10	M8	10	0,6	0,6

F_{rec}: Recommended loads in all directions incl. safety factors Bending of the eyebolt or hook is decisive.















Chemical Fastening Systems



ResiFIX		182
SH		199
SH-1000		199
IGH		199
Resi AST		200
VA		201
VA AST		198

ResiFIX

Systems in Comparison

	ResiFIX VVSF				ResiFIX VY ECO SF	ResiFIX PVSF				ResiFIX Pure Epoxy Plus EPP SF	
	300	345	410	300	300	165	300	345	410	585	585
											
Content [ml]	280	345	410	300	300	165	300	345	410	585	585
Nozzles included 	2	2	1	2	2	2	1	1	1	1	1
Types	Standard			Cool	Standard	Standard			Standard		
Shelf life*	18 months			18 mon.	18 months	18 months	18 months		24 months		
A4 STAINLESS STEEL 	steel 4.6, 5.8, 8.8 stainless steel				steel 4.6, 5.8, 8.8 stainless steel	steel 4.6, 5.8, 8.8 stainless steel			steel 4.6, 5.8, 8.8 stainless steel		
Reinforcing bars 	✓				✓ (only Option 7)	X			✓		
Option 1 						X					
Option 7 											
Rebar 					X	X					
	X				X	X			✓ only post-installed rebar connection ✓		
100 YEARS 	50 years				50 years	50 years			✓ 50 years		
Masonry 									X		
R 120 					X	X			 post-installed rebar		
FIXING seismic 						X			 X		
LEED tested 	✓				✓	✓			✓		
STYRENE FREE 	✓				✓	✓			✓		
Performance in non-cracked concrete C20/25 (M10x90, 5.8)											
Performance in hollow brick HLZ 12 (M10x130)									X		
Wet drill holes	✓				✓	✓			✓		
	✓				✓	✓			✓		
Suitable for contact with drinking water	✓				X	X			✓ X		
Min. temperature of base material	≥ -10°C		≥ -20°C		≥ -5°C	≥ -5°C			≥ 0°C ≥ +5°C		
Temperature range after complete curing	-40°C to +120°C				-40°C to +80°C	-40°C to +80°C			-40°C to +72°C		
Chemical resistance	very high				high	high			excellent		
Odour	marginal				medium	medium			marginal		

Fastening injection system ResiFIX



Advantages



Injection mortar ResiFIX VYSF (styrene free)



Injection mortar ResiFIX VY ECO SF (styrene free)



Injection mortar ResiFIX PYSF (styrene free)



Injection mortar ResiFIX Pure Epoxy EPP (styrene free)



Injection mortar ResiFIX Pure Epoxy EP (styrene free)

Approvals and certificates

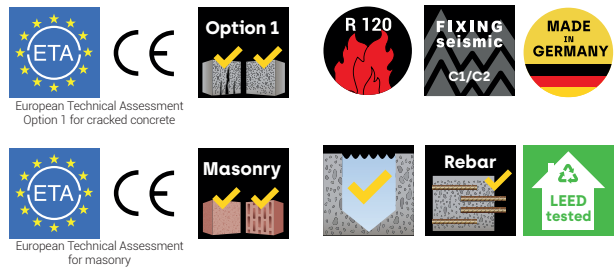

Suitable building materials

Very suitable



- Concrete
- Solid brick
- Solid sand-lime brick
- Lightweight solid concrete blocks
- Aerated concrete
- Hollow brick
- Hollow sand-lime brick
- Lightweight hollow concrete blocks
- Natural stone (risk of discolouration)

Typical applications

- Steel constructions
- Cantilevers
- Façade substructures
- Machines
- Guard rails
- Canopies
- Distance mountings
- Door and window frames
- Stairways
- Wood constructions
- Cable trays
- Pipe installations

Fastening injection system ResiFIX

Mounting in concrete and solid brick

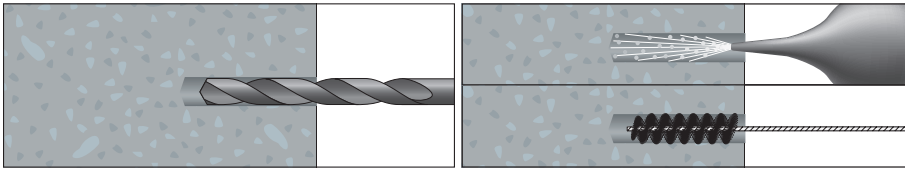

1. Drill hole

2. Clean hole (blow 4x, brush 4x)

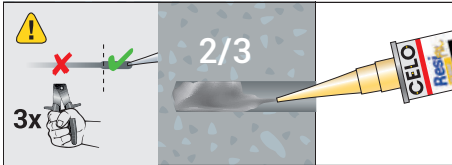

3. Discard first 10 cm. Inject necessary amount of chemical mortar, (min. 2/3 of hole)

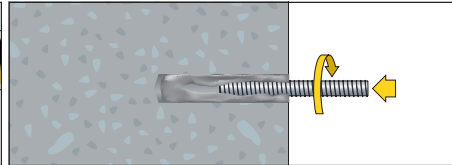

4. Push the anchor rod into the hole while turning

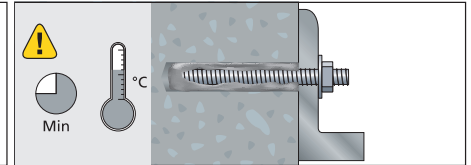

5. Respect curing time before applying any load or torque

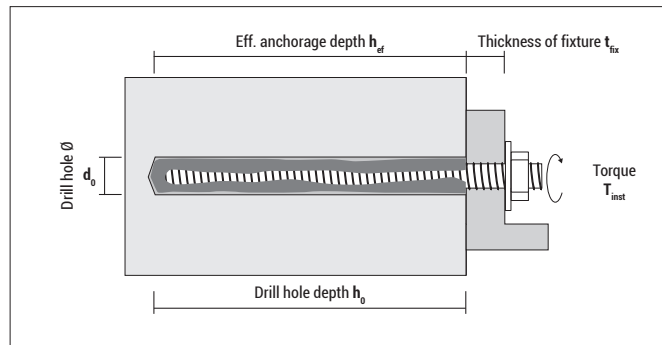

Mounting in hollow brick

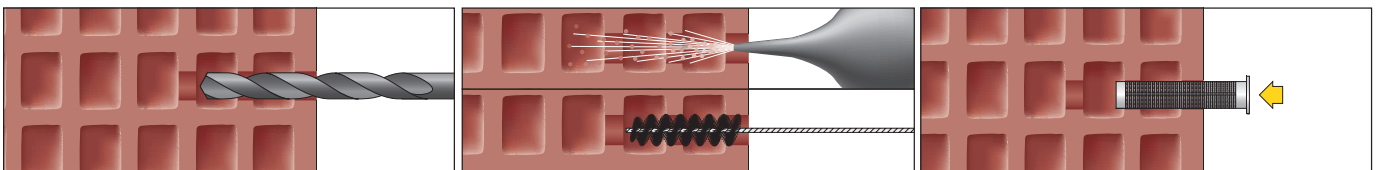

1. Drill hole

2. Clean hole (blow 2x, brush 2x)

3. Insert anchor sleeve

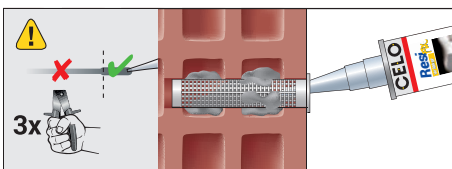

4. Discard first 10 cm. Inject necessary amount of chemical mortar (fill sleeve completely)

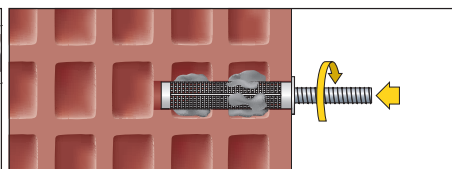

5. Push the anchor rod into the hole while turning

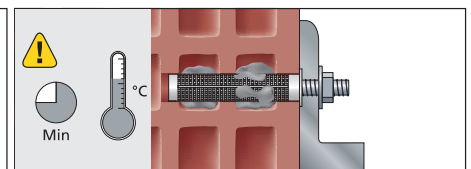

6. Respect curing time before applying any load or torque

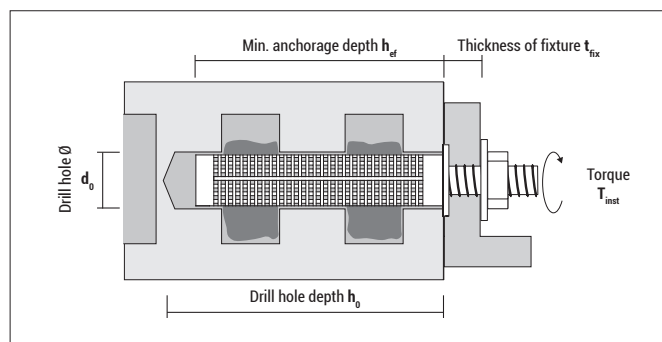

Fastening injection system ResiFIX

Estimation of needed volume (all types)

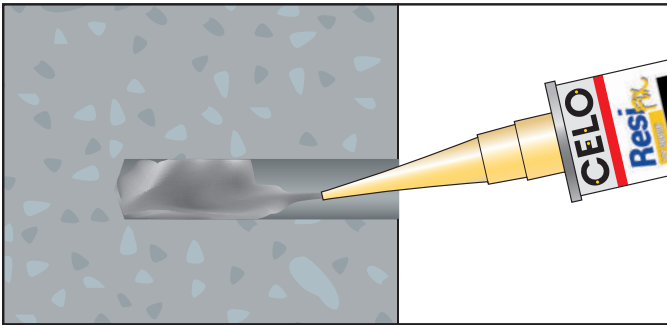

Consumption in solid materials Calculation method: Complete filling of the drill hole*

Anchor stud RAST or VA AST	d ₀ [mm]	Drill hole h _{ef, Stand} ¹⁾ [mm]	Volume [cm ³ =ml]	Number of fixings per ResiFIX cartridge				
				165 ml [fixings]	280 ml [fixings]	300 ml [fixings]	345 ml [fixings]	410 ml [fixings]
M8	10	80	6,3	26,3	44,6	47,8	54,9	65,3
M10	12	90	10,2	16,2	27,5	29,5	33,9	40,3
M12	14	110	17,0	9,7	16,5	17,7	20,4	24,2
M16	18	125	31,8	5,2	8,8	9,4	10,9	12,9
M20	24	170	76,9	2,1	3,6	3,9	4,5	5,3
M24	28	210	129,2	1,3	2,2	2,3	2,7	3,2
M30	35	280	269,3	0,6	1,0	1,1	1,3	1,5

* According to the ETA assessment only 2/3 of the drill hole has to be filled with mortar. The experience shows that the user uses more, so that the filling of the complete drill hole is calculated here.

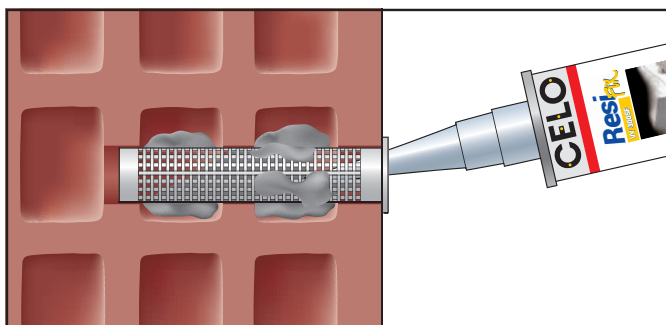

Consumption in hollow bricks with sleeve Calculation method: Complete filling of the sleeve + 15%

Sleeve	Anchor stud RAST or VA AST	Drill hole		Volume [cm ³ =ml]	Number of fixings per ResiFIX cartridge				
		d ₀ [mm]	h ₀ [mm]		165 ml [fixings]	280 ml [fixings]	300 ml [fixings]	345 ml [fixings]	410 ml [fixings]
SH 12x80	M6 / M8	12	85	9,1	15,9	26,9	28,8	33,2	39,4
SH 16x85	M8 / M10	16	90	17,1	8,4	14,3	15,3	17,6	20,9
SH 16x130	M8 / M10	16	135	26,1	5,5	9,3	10,0	11,5	13,6
SH 20x85	M12 / M16	20	90	26,7	5,4	9,1	9,8	11,2	13,4
SH 20x130	M12 / M16	20	135	40,8	3,5	6,0	6,4	7,3	8,7
SH 20x200	M12 / M16	20	205	62,8	2,3	3,9	4,2	4,8	5,7

Fastening injection system

ResiFIX VYSF



Approvals and certificates



European Technical Assessment
Option 1 for cracked concrete
(M8 - M30, Ø8 - Ø32)



European Technical Assessment
for masonry
(M8 - M16)



European Technical Assessment
for post-installed rebar
connections (Ø8 - Ø32)



Approved for anchor rods and reinforced steel bars

- **Various applications**



Class A+: Lowest emissions of critical substances in closed spaces

- **Harmless to health after curing**



Sustainability certification LEED

- **Environmentally friendly, low-pollutant, low-emission and sustainable construction product**



Usage under seismic conditions

- **Tested for use in areas with high risk of earthquakes**



European Technical Assessment Option 1 for cracked and non-cracked concrete (M8 - M30)

- **For a wide range of safety critical applications**



Apart from the 410 ml cartridge, two mixing nozzles are included

- **You can continue working immediately after an interruption**



M10-90 mm
C20/25

Very high load values

- **Heavy-duty usage**



Usage also in water-filled drill holes and suitable for contact with drinking water

- **Extended range of applications**



Fire resistance test R120

- **Fulfills fire protection requirements**

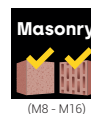

European Technical Assessment for masonry (M8 - M16)

- **For more application flexibility**



Styrene free

- **Reduced odour exposure**

Fastening injection system ResiFIX VYSF



Vynylester VYSF (styrene free)

Type	Art-No	Content [ml]	Mixings nozzles included [pcs]	Shelf life [months]		€ / pc	[pcs]
VY 300 SF	300VSF	280	2	18	●		12
VY 345 SF	345VSF	345	2	18	●		12
VY 410 SF	410VYSF	410	1	18	●		12



Vynylester VYSF Cool (styrene free)

for -20°C to +10°C



Type	Art-No	Content [ml]	Mixings nozzles included [pcs]	Shelf life [months]		€ / pc	[pcs]
VY 300 SF Cool	300VCSF	300	2	18	●		12

Seasonal article



30 x 40 x 23 cm

Universal box with ResiFIX VY 300 SF, VY 345 SF

Type	Art-No	Content [cartridges]	Mixings nozzles included [pcs]	Shelf life [months]		€ / box	[pcs]
VY 300 SF in universal box	SYS300VSF20	20	40	18	●		1
VY 345 SF in universal box	SYS345VSF20	20	40	18	●		1

Curing times ResiFIX Vynylester VYSF

Temperature of building material	[°C]	> -10 ¹⁾	> -5	> 0	> +5	> +10	> +20	> +30	> +40
Max. working time	[min]	90	90	45	25	15	6	4	1,5
Min. curing time ²⁾	[min]	24h	14h	7h	2h	80	45	25	15

¹⁾ Cartridge temperature min. 15 °C

²⁾ Double curing time in wet concrete

Curing times ResiFIX Vynylester VYSF Cool

Temperature of building material	[°C]	> -20	> -15	> -10	> -5	> 0	> +5	+10	X
Max. working time	[min]	75	55	35	20	10	6	6	
Min. curing time ¹⁾	[min]	24h	16h	10h	5h	2,5h	80	60	

¹⁾ Double curing time in wet concrete

Fastening injection system ResiFIX VYSF



Fastening in concrete [Standard and Cool]

Permissible loads F_{per} in [kN] in non-cracked concrete C20/25 (option 7) and cracked concrete C20/25 (option 1) without influence of edge distances and spacing as well as installation parameters and unit dimensions. The permissible loads F_{per} include the partial safety factors for the resistance from the ETA and a partial safety factor for the actions of $\gamma_F = 1.4$. Design method according TR 055. The ETA assessment must be observed in the design.

Anchor studs RESI AST, VA AST	M8	M10	M12	M16	M20	M24	M 27	M30
Drill hole \varnothing d_0 [mm]	10	12	14	18	24	28	30	35
Anchorage depth $h_{ef, min} / h_{ef, stand} / h_{ef, max}$ [mm]	60 / 80 / 160	60 / 90 / 200	70 / 110 / 240	80 / 125 / 320	90 / 170 / 400	96 / 210 / 480	108 / 240 / 540	120 / 280 / 600

Permissible tension load ¹⁾²⁾ [24 °C / 40 °C] ³⁾ in non-cracked concrete [dry or wet]

	N_{per} [kN]	M8	M10	M12	M16	M20	M24	M 27	M30
Zinc plated 5.8		7,2 / 8,7 / 8,7	9,0 / 13,5 / 13,8	11,7 / 19,7 / 20,0	14,3 / 28,0 / 37,3	17,1 / 44,4 / 58,3	18,8 / 61,0 / 83,9	23,1 / 74,5 / 109,4	26,3 / 93,9 / 133,5
Stainless steel A4		7,2 / 9,6 / 9,8	9,0 / 13,5 / 15,5	11,7 / 19,7 / 22,5	14,3 / 28,0 / 41,9	17,1 / 44,4 / 65,5	18,8 / 61,0 / 94,3	23,1 / 57,3 / 57,4	26,3 / 70,0 / 70,0

Permissible tension load ¹⁾²⁾ [24 °C / 40 °C] ³⁾ in cracked concrete [dry or wet]

	N_{per} [kN]	M8	M10	M12	M16	M20	M24	M 27	M30
Zinc plated 5.8		2,9 / 3,8 / 7,7	3,7 / 5,6 / 12,5	5,8 / 9,1 / 19,7	8,8 / 13,7 / 35,1	12,2 / 23,3 / 54,9	13,4 / 34,6 / 79,0	16,5 / 52,5 / 109,4	18,8 / 66,9 / 133,5
Stainless steel A4		2,9 / 3,8 / 7,7	3,7 / 5,6 / 12,5	5,8 / 9,1 / 19,7	8,8 / 13,7 / 35,1	12,2 / 23,3 / 54,9	13,4 / 34,6 / 79,0	16,5 / 52,5 / 57,4	18,8 / 66,9 / 70,0

Permissible tension load ¹⁾²⁾ [50 °C / 80 °C] ³⁾ in non-cracked concrete [dry or wet]

	N_{per} [kN]	M8	M10	M12	M16	M20	M24	M 27	M30
Zinc plated 5.8		5,4 / 7,2 / 8,7	6,7 / 10,1 / 13,8	9,4 / 14,8 / 20,0	14,3 / 22,4 / 37,3	17,1 / 38,1 / 58,3	18,8 / 53,4 / 83,9	23,1 / 60,6 / 109,4	26,3 / 68,1 / 133,5
Stainless steel A4		5,4 / 7,2 / 9,8	6,7 / 10,1 / 15,5	9,4 / 14,8 / 22,5	14,3 / 22,4 / 41,9	17,1 / 38,1 / 65,5	18,8 / 53,4 / 94,3	23,1 / 57,4 / 57,4	26,3 / 68,1 / 70,0

Permissible tension load ¹⁾²⁾ [50 °C / 80 °C] ³⁾ in cracked concrete [dry or wet]

	N_{per} [kN]	M8	M10	M12	M16	M20	M24	M 27	M30
Zinc plated 5.8		1,8 / 2,4 / 4,8	2,6 / 3,9 / 8,7	4,2 / 6,6 / 14,4	6,4 / 10,0 / 25,5	9,0 / 17,0 / 39,9	11,5 / 25,1 / 57,4	16,5 / 36,4 / 78,8	18,8 / 47,1 / 101,0
Stainless steel A4		1,8 / 2,4 / 4,8	2,6 / 3,9 / 8,7	4,2 / 6,6 / 14,4	6,4 / 10,0 / 25,5	9,0 / 17,0 / 39,9	11,5 / 25,1 / 57,4	16,5 / 36,4 / 57,4	18,8 / 47,1 / 70,0

Permissible shear load ¹⁾ in non-cracked concrete

	V_{per} [kN]	M8	M10	M12	M16	M20	M24	M 27	M30
Zinc plated 5.8		5,2	8,3	12,0	22,4	35,0	45,2 / 50,4 / 50,4	55,5 / 65,6 / 65,6	63,2 / 80,1 / 80,1
Stainless steel A4		5,9	9,3	13,5	25,1	39,2	45,2 / 56,5 / 56,5	34,5 / 34,5 / 34,5	42,1 / 42,1 / 42,1

Permissible shear load ¹⁾ in cracked concrete

	V_{per} [kN]	M8	M10	M12	M16	M20	M24	M 27	M30
Zinc plated 5.8		5,2 / 5,2 / 5,2	8,3	12,0	21,1 / 22,4 / 22,4	29,3 / 35,0 / 35,0	32,2 / 50,4 / 50,4	39,6 / 65,6 / 65,6	45,1 / 80,1 / 80,1
Stainless steel A4		5,7 / 5,9 / 5,9	9,0 / 9,3 / 9,3	13,5	21,1 / 25,1 / 25,1	29,3 / 39,2 / 39,2	32,2 / 56,5 / 56,5	34,5 / 34,5 / 34,5	42,1 / 42,1 / 42,1

	M_{per} [Nm]	M8	M10	M12	M16	M20	M24	M 27	M30
Permissible bending moment (Zinc plated 5.8)		10,7	21,4	37,4	94,9	185,2	320,0	476,2	642,1
Permissible bending moment (Stainless steel A4)		12,0	24,0	41,9	106,4	207,8	359,0	250,1	337,2

Spacing and edge distance

		M8	M10	M12	M16	M20	M24	M 27	M30
Spacing	$s_{cr, N}$ [mm]	180 / 240 / 480	180 / 270 / 600	210 / 330 / 720	240 / 375 / 960	270 / 510 / 1200	288 / 630 / 1440	324 / 720 / 1620	360 / 840 / 1800
Edge distance	$c_{cr, N}$ [mm]	90 / 120 / 240	90 / 135 / 300	105 / 165 / 360	120 / 188 / 480	135 / 255 / 600	144 / 315 / 720	162 / 360 / 810	180 / 420 / 900
Minimum spacing	s_{min} [mm]	40	50	60	80	100	120	135	150
Minimum edge distance	c_{min} [mm]	40	50	60	80	100	120	135	150
Min. thickness of structural part	h_{min} [mm]	$h_{ef} + 30 \text{ mm} \geq 100 \text{ mm}$				$h_{ef} + 2d_0$			
Max. installation torque	$T_{inst} \leq$ [Nm]	10	20	40	80	120	160	180	200

¹⁾ Values are valid for $h_{ef, min} / h_{ef, stand} / h_{ef, max}$

²⁾ For higher concrete strengths up to C50/60 the values increase by max. 10%.

³⁾ Max. long term temperature / max. short term temperature after installation. For temperature range 72°C/120°C please see ETA assessment

If underrun the char. spacing or edge distance (C_{cr} or S_{cr}) the loads must be reduced. h_{min} , S_{min} and C_{min} must be observed.

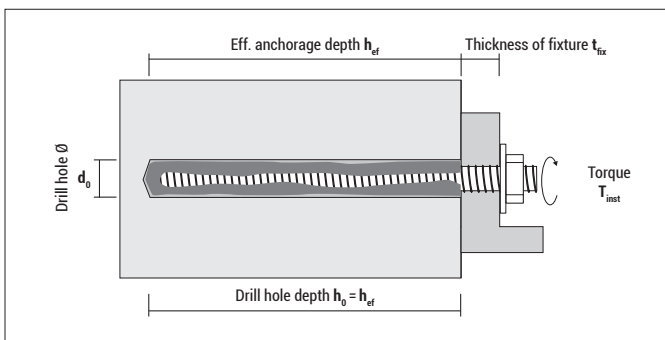

Fastening injection system ResiFIX VYSF



Fastening in masonry (Solid and hollow brick) Standard and Cool

Permissible loads in [kN] and installation parameters - selection; for additional brick types and application conditions please see ETA assessment.

Suitable building materials	Density ρ [kg/dm ³]	Compressive strength f_b [N/mm ²]	Anchor studs RESI AST, VA AST Size	Sleeve Size	Min. Anchorage depth h_{ef} [mm]	Use category dry / dry 24°C/40°C ¹⁾		
						Tension load N_{per} [kN]	Shear load V_{per} [kN]	
Solid sand-lime brick KS (NF)		$\geq 2,0$	≥ 28	M8	without / SH 12x80	80 / 80	2,00 / 2,00	2,00 / 2,00
				M10	without / SH 16x85	90 / 85	2,00 / 2,00	2,00 / 2,00
				M12	without / SH 20x85	100 / 85	2,00 / 2,00	2,00 / 2,00
				M16	without / SH 20x85	100 / 85	2,00 / 2,00	2,00 / 2,00
Solid brick Mz (DF)		$\geq 2,0$	≥ 20	M8	without / SH 12x80	80 / 80	2,00 / 2,00	2,29 / 2,29
				M10	without / SH 16x85	90 / 85	2,00 / 2,00	2,29 / 2,29
				M12	without / SH 20x85	100 / 85	2,00 / 2,00	2,29 / 2,29
				M16	without / SH 20x85	100 / 85	2,29 / 2,29	3,43 / 3,43
Aerated concrete AAC2 Aerated concrete AAC4		$\geq 0,35$ $\geq 0,50$	≥ 2 ≥ 4	M8	without	80	0,43 / 1,07 (AAC2/AAC4)	0,54 / 1,61 (AAC2/AAC4)
				M10	without	90	0,43 / 1,07 (AAC2/AAC4)	0,89 / 2,68 (AAC2/AAC4)
				M12	without	100	0,71 / 1,79 (AAC2/AAC4)	0,89 / 2,68 (AAC2/AAC4)
Hollow sand-lime brick KSL (KSL 3DF)		$\geq 1,4$	≥ 12	M8	SH 16x85	85	0,64	1,53
				M10	SH 16x85	85	0,64	1,53
				M10	SH 16x130	130	0,64	1,53
				M12	SH 20x85	85	1,65	1,53
Hollow brick HLz (10DF)		$\geq 1,25$	≥ 12	M8	SH 12x80	80	0,55	1,77
				M10	SH 16x85	85	0,55	1,77
				M10	SH 16x130	130	0,55	1,77
				M12	SH 20x85	85	1,11	1,77
				M16	SH 20x85	85	1,11	2,55

N_{per} / V_{per} : Permissible loads incl. safety factors (γ_M and $\gamma_F = 1,4$), without influence of spacing and edge distance.

Drilling method: KS and Mz: hammer drilling; Aerated concrete, KSL and HLz: rotary drilling

¹⁾ Max. long-term temperature / max. short-term temperature after installation.

Spacing and edge distance

Suitable building materials	Anchor stud	Sleeve	Char. Edge distance c_{cr} [mm]	Min. Edge distance c_{min} [mm]	Char. Spacing parallel to the bearing joint $s_{cr,II}$ [mm]	Char. Spacing perpendicular to the bearing joint $s_{cr,I}$ [mm]	Min. Spacing s_{min} [mm]	Max. Torque T_{inst} [Nm]
Solid sand-lime brick KS (NF)	M8	without	150	60	240	150	75	10
	M10	without	150	60	240	150	75	10
	M12	without	150	60	240	150	75	15
	M16	without	150	60	240	150	75	15
Solid brick Mz (DF)	M8	without	150	60	240	130	65	10
	M10	without	150	60	240	130	65	10
	M12	without	150	60	240	130	65	10
Aerated concrete AAC6	M8	without	150	50*	300	250	50	5
	M10	without	150	50*	300	250	50	5
	M12	without	150	50*	300	250	50	10
Hollow sand-lime brick KSL (KSL 3DF)	M8	SH 12x80	120	60	240	120	120	5
	M10	SH 16x85	120	60	240	120	120	5
	M10	SH 16x130	120	60	240	120	120	5
Hollow brick HLz (10DF)	M12,M16	SH 20x85	120	60	240	120	120	8
	M8	SH 12x80	120	50	300	250	50	5
	M10	SH 16x85	120	50	300	250	50	10
	M10	SH 16x130	120	50	300	250	50	10
	M12,M16	SH 20x85	120	50	300	250	50	10

Permissible bending moment		Anchor stud			
Steel		M8	M10	M12	M16
Zinc plated 5.8	M_{per} [Nm]	10,9	21,1	37,7	94,4
Stainless steel A4	M_{per} [Nm]	11,9	23,8	42,1	106,7

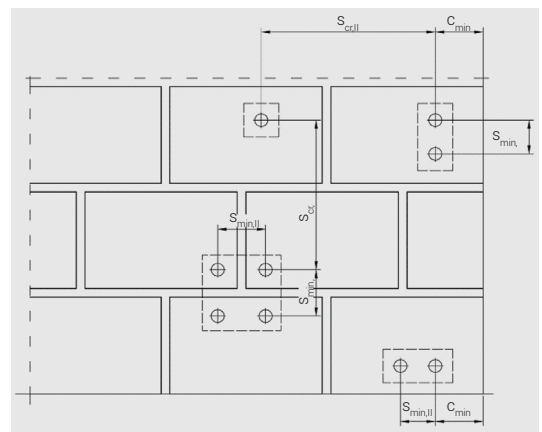

* Values are valid for pull-out load; for shear load parallel to the free edge: 75 mm, for shear load perpendicular to the free edge: $1,5 \times h_{ef}$
Group factors for anchor groups under tension, shear load parallel or perpendicular to the free edge: please see ETA assessment

Fastening injection system

ResiFIX VY

ECO SF



Approvals and certificates



European Technical Assessment Option 1 for cracked concrete (M8 - M16)

European Technical Assessment Option 7 for non-cracked concrete (M8 - M24, Ø8 - Ø25)

European Technical Assessment for masonry (M8 - M16)



Approved for anchor rods and reinforced steel bars (Option 7, non-cracked concrete)

- **Various applications**



Class A+: Lowest emissions of critical substances in closed spaces

- **Harmless to health after curing**



Sustainability certification LEED

- **Environmentally friendly, low-pollutant, low-emission and sustainable construction product**



European Technical Assessment Option 1 for cracked (M8 - M16) and non-cracked concrete (M8 - M24)

- **For a wide range of safety critical applications**



Usage under seismic conditions

- **Tested for use in areas with high risk of earthquakes**



Two mixing nozzles are included with every cartridge

- **You can continue working immediately after an interruption**



Usage also in water-filled drill holes

- **Extended range of applications**



Good load values in concrete and masonry

- **Multi-material usage**

M10-90 mm
C20/25



European Technical Assessment for masonry (M8 - M16)

- **For more application flexibility**



Styrene free

- **Reduced odour exposure**



Viny Lester VY ECO SF [styrene free]

Type	Art-No	Content [ml]	Mixings nozzles included [pcs]	Shelf life [months]	ETA	€ / pc	Icon [pcs]
VY ECO 300 SF	300VYECOSF	300	2	18	●		12

Curing times ResiFIX Viny Lester VY ECO SF

Temperature of building material	> -5	> 0	> +5	> +10	> +20	> +30	> +40
Max. working time [min]	90	45	25	20	6	4	2
Min. curing time ²⁾ [min]	6h	3h	2h	100	45	25	20

¹⁾ Cartridge temperature min. 15 °C

²⁾ Double curing time in wet concrete



Fastening in concrete

Permissible loads F_{per} in [kN] in non-cracked concrete C20/25 (Option 7) and cracked concrete C20/25 (Option 1) without influence of spacing and edge distance, installation parameters and unit dimensions. Total safety factors as per ETAG 001 included (γ_M and γ_p). Design according to TR029. See ETA assessment for design and calculations.

Anchor studs RESI AST, VA AST	M8	M10	M12	M16	M20	M24
Drill hole \varnothing d_0 [mm]	10	12	14	18	24	28
Anchorage depth $h_{ef,min}/h_{ef,stand}/h_{ef,max}$ [mm]	60 / 80 / 160	60 / 90 / 200	70 / 110 / 240	80 / 125 / 320	90 / 170 / 400	96 / 210 / 480

Permissible tension load ^{1) 2)} [24 °C / 40 °C] ³⁾ in non-cracked concrete (dry or wet)

	N_{per} [kN]	M8	M10	M12	M16	M20	M24
Zinc plated 5.8		5,1 / 6,8 / 8,7	6,0 / 9,0 / 13,8	8,4 / 13,2 / 20,0	12,8 / 19,9 / 37,3	17,1 / 33,9 / 58,3	18,8 / 50,3 / 83,9
Stainless steel A4		5,1 / 6,8 / 9,8	6,0 / 9,0 / 15,5	8,4 / 13,2 / 22,5	12,8 / 19,9 / 41,9	17,1 / 33,9 / 65,5	18,8 / 50,3 / 94,3

Permissible tension load ^{1) 2)} [24 °C / 40 °C] ³⁾ in cracked concrete (dry or wet)

	N_{per} [kN]	M8	M10	M12	M16	M20	M24
Zinc plated 5.8		2,7 / 3,6 / 7,2	3,4 / 5,0 / 11,2	4,7 / 7,4 / 16,2	7,2 / 11,2 / 28,7	–	–
Stainless steel A4		2,7 / 3,6 / 7,2	3,4 / 5,0 / 11,2	4,7 / 7,4 / 16,2	7,2 / 11,2 / 28,7	–	–

Permissible tension load ^{1) 2)} [50 °C / 80 °C] ³⁾ in non-cracked concrete (dry or wet)

	N_{per} [kN]	M8	M10	M12	M16	M20	M24
Zinc plated 5.8		3,9 / 5,2 / 8,7	4,5 / 6,7 / 13,8	6,3 / 9,9 / 20,0	9,6 / 15,0 / 37,3	13,5 / 25,4 / 58,3	17,2 / 37,7 / 83,9
Stainless steel A4		3,9 / 5,2 / 9,8	4,5 / 6,7 / 15,0	6,3 / 9,9 / 21,5	9,6 / 15,0 / 38,3	13,5 / 25,4 / 59,8	17,2 / 37,7 / 86,2

Permissible tension load ^{1) 2)} [50 °C / 80 °C] ³⁾ in cracked concrete (dry or wet)

	N_{per} [kN]	M8	M10	M12	M16	M20	M24
Zinc plated 5.8		2,1 / 2,8 / 5,6	2,6 / 3,9 / 8,7	3,7 / 5,8 / 12,6	5,6 / 8,7 / 22,3	–	–
Stainless steel A4		2,1 / 2,8 / 5,6	2,6 / 3,9 / 8,7	3,7 / 5,8 / 12,6	5,6 / 8,7 / 22,3	–	–

Permissible shear load ¹⁾ in non-cracked concrete

	V_{per} [kN]	M8	M10	M12	M16	M20	M24
Zinc plated 5.8		5,2	8,3	12,0	22,4	35,0	45,2 / 50,4 / 50,4
Stainless steel A4		5,9	9,3	13,5	25,1	39,2	45,2 / 56,5 / 56,5

Permissible shear load ¹⁾ in cracked concrete

	V_{per} [kN]	M8	M10	M12	M16	M20	M24
Zinc plated 5.8		5,2 / 5,2 / 5,2	8,1 / 8,3 / 8,3	11,3 / 12,0 / 12,0	17,2 / 22,4 / 22,4	–	–
Stainless steel A4		5,9 / 5,9 / 5,9	8,1 / 9,3 / 9,3	11,3 / 13,5 / 13,5	17,2 / 25,1 / 25,1	–	–

Permissible bending moment (Zinc plated 5.8)	M_{per} [Nm]	M8	M10	M12	M16	M20	M24
		10,7	21,4	37,4	94,9	185,2	320,0
Permissible bending moment (Stainless steel A4)	M_{per} [Nm]						
		12,0	24,0	41,9	106,4	207,8	359,0

Spacing and edge distance

Spacing	$s_{cr,N}$ [mm]	M8	M10	M12	M16	M20	M24
		180 / 240 / 480	180 / 270 / 600	210 / 330 / 720	240 / 375 / 960	270 / 510 / 1200	288 / 630 / 1440
Edge distance	$c_{cr,N}$ [mm]						
		90 / 120 / 240	90 / 135 / 300	105 / 165 / 360	120 / 188 / 480	135 / 255 / 600	144 / 315 / 720
Minimum spacing	s_{min} [mm]						
		40	50	60	80	100	120
Minimum edge distance	c_{min} [mm]						
		40	50	60	80	100	120
Min. thickness of structural part	h_{min} [mm]	$h_{ef} + 30 \text{ mm} \geq 100 \text{ mm}$				$h_{ef} + 2d_0$	
Max. installation torque	$T_{inst} \leq$ [Nm]						
		10	20	40	80	120	160

¹⁾ Values are valid for $h_{ef,min} / h_{ef,stand} / h_{ef,max}$

²⁾ For higher concrete strengths up to C50/60 the values increase by max. 19%.

³⁾ Max. long term temperature / max. short term temperature after installation. For temperature range 72°C/120°C please see ETA assessment

If underrun the char. spacing or edge distance (C_{cr} or S_{cr}) the loads must be reduced. h_{min} , S_{min} and C_{min} must be observed.

Fastening injection system ResiFIX VY ECO SF



Fastening in masonry (Solid and hollow brick)

Permissible loads in [kN] and installation parameters - selection; for additional brick types and application conditions please see ETA assessment.

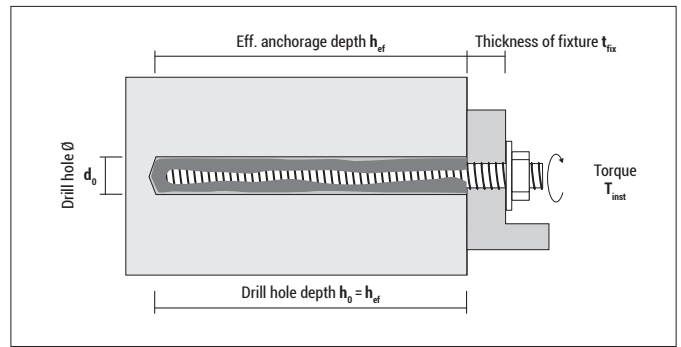

Suitable building materials		Density ρ [kg/dm ³]	Compressive strength f_b [N/mm ²]	Anchor studs RESI AST, VA AST Size	Sleeve Size	Min. Anchorage depth h_{ef} [mm]	Use category dry / dry 24°C/40°C ¹⁾ Tension load N_{per} [kN] Shear load V_{per} [kN]	
Solid sand-lime brick KS (NF)		≥ 2,0	≥ 20	M8	without / SH 12x80	80 / 80	1,29 / 1,14	1,29 / 1,14
				M10	without / SH 16x85	90 / 85	1,29 / 1,14	1,29 / 1,29
				M12	without / SH 20x85	100 / 85	1,57 / 1,14	1,43 / 1,43
				M16	without / SH 20x85	100 / 85	1,29 / 1,14	1,43 / 1,43
Solid brick Mz (DF)		≥ 1,6	≥ 20	M8	without / SH 12x80	80 / 80	0,71 / 0,86	1,29 / 1,14
				M10	without / SH 16x85	90 / 85	0,71 / 0,86	1,57 / 1,43
				M12	without / SH 20x85	100 / 85	0,57 / 0,86	2,14 / 1,43
				M16	without / SH 20x85	100 / 85	1,00 / 0,86	2,14 / 1,43
Aerated concrete AAC4		≥ 0,50	≥ 4	M8	without	80	0,32	0,54
				M10	without	90	0,89	0,71
				M12	without	100	0,89	0,89
				M16	without	100	1,25	1,25
Hollow sand-lime brick KSL (KSL 3DF)		≥ 1,4	≥ 12	M8	SH 12x80	80	0,57	0,71
				M10	SH 16x85	85	0,57	1,00
				M10	SH 16x130	130	1,00	1,29
				M12	SH 20x85	85	0,57	1,00
				M16	SH 20x85	85	0,57	1,00
Hollow brick HLz (16DF)		≥ 0,8	≥ 12	M8	SH 12x80	80	0,43	1,00
				M10	SH 16x85	85	0,71	1,71
				M10	SH 16x130	130	1,00	2,29
				M12	SH 20x85	85	1,00	1,71
				M16	SH 20x85	85	1,00	1,71

N_{per}, V_{per} : Permissible loads incl. safety factors (v_M and $v_F = 1,4$), without influence of spacing and edge distance.

Drilling method: KS and Mz: hammer drilling; Aerated concrete, KSL and HLz: rotary drilling

¹⁾ Max. long term temperature / max. short term temperature. Long-term temperature is constant over a longer period of time. The short-term temperature is only present for a short time (day/night change).

Spacing and edge distance

Suitable building materials	Anchor stud	Sleeve	Char. Edge distance c_{cr} [mm]	Min. Edge distance c_{min} [mm]	Char. Spacing parallel to the bearing joint $s_{cr, }$ [mm]	Char. Spacing perpendicular to the bearing joint $s_{cr,\perp}$ [mm]	Min. Spacing s_{min} [mm]	Max. Torque T_{inst} [Nm]
Solid sand-lime brick KS (NF)	M8	without	120	120	240	240	240	10
	M10	without	135	135	270	270	270	20
	M12	without	150	150	300	300	300	20
	M16	without	150	150	300	300	300	20
Solid brick Mz (DF)	M8	without	120	120	240	240	240	6
	M10	without	135	135	270	270	270	10
	M12	without	150	150	300	300	300	10
	M16	without	150	150	300	300	300	10
Aerated concrete AAC4	M8	without	120	120	240	240	240	2
	M10	without	135	135	270	270	270	2
	M12	without	150	150	300	300	300	2
	M16	without	150	150	300	300	300	2
Hollow sand-lime brick KSL (KSL 3DF)	M8	SH 12x80	100	100	240	240	113*	8
	M10	SH 16x85	100	100	240	240	113*	8
	M10	SH 16x130	100	100	240	240	113*	8
	M12,M16	SH 20x85	120	120	240	240	113*	8
Hollow brick HLz (16DF)	M8	SH 12x80	100	100	497	497	238**	6
	M10	SH 16x85	100	100	497	497	238**	6
	M10	SH 16x130	100	100	497	497	238**	6
	M12,M16	SH 20x85	120	120	497	497	238**	6

Permissible bending moment		Anchor stud			
Steel		M8	M10	M12	M16
Zinc plated 5.8	M_{per} [Nm]	10,8	21,2	37,7	94,9
Stainless steel A4	M_{per} [Nm]	11,9	23,8	42,1	106,2

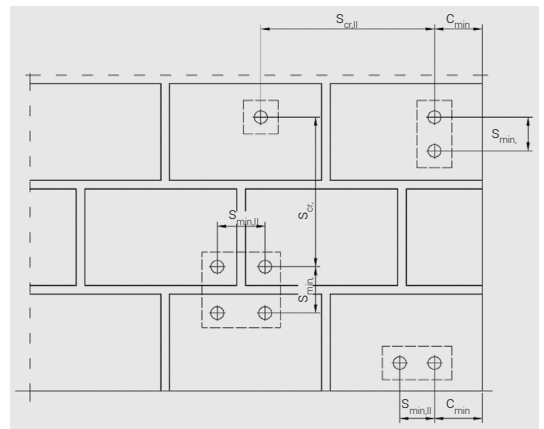

* Values are valid for $s_{min,\perp}$. For $s_{min,||}$ 240 mm is valid.

** Values are valid for $s_{min,\perp}$. For $s_{min,||}$ 497 mm is valid.

Fastening injection system

ResiFIX PYSF



Approvals and certificates



European Technical Assessment
Option 7 for non-cracked concrete
(M8 - M16)



European Technical Assessment
for masonry
(M8 - M16)



Class A+: Lowest emissions of critical substances in closed spaces

- Harmless to health after curing



Sustainability certification LEED

- Environmentally friendly, low-pollutant, low-emission and sustainable construction product



European Technical Assessment Option 7 for non-cracked concrete (M8 - M16)

- For standard applications in concrete



Usage also in water-filled drill holes

- Extended range of applications



M10-90 mm
C20/25

Good load values at a very good price-performance ratio



European Technical Assessment for masonry (M8 - M16)

- For more application flexibility



Styrene free

- Reduced odour exposure

Fastening injection system ResiFIX PYSF



Polyester PYSF (styrene free)

Type	Art-No	Content [ml]	Mixings nozzles included [pcs]	Shelf life [months]		€ / pc	[pcs]
PY 300 SF	300PSF	300	1	18	●		12
PY 345 SF	345PSF	345	1	18	●		12
PY 410 SF	410PYSF	410	1	18	●		12



ResiFIX PYSF (styrene free)

Type	Art-No	Content [ml]	Mixings nozzles included [pcs]	Shelf life [months]		€ / pc	[pcs]	[Blister]
PY 165 SF	165PSF	165	2	18	●		1	12

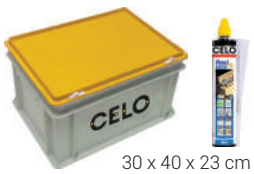

Universal box with ResiFIX PY 300 SF, PY 345 SF

Type	Art-No	Content [cartridges]	Mixings nozzles included [pcs]	Shelf life [months]		€ / box	[pcs]
PY 300 SF in universal box	SYS300PSF20	20	20	18	●		1
PY 345 SF in universal box	SYS345PSF20	20	20	18	●		1

Curing times ResiFIX Polyester PYSF

Temperature of building material	[°C]	> -10	> -5	> 0	> +5	> +10	> +20	> +30	> +40
Max. working time	[min]	–	90	45	25	20	6	4	1,5
Min. curing time ¹⁾	[min]	–	6h	3h	2h	100	45	25	15

¹⁾ Double curing time in wet concrete

Fastening injection system ResiFIX PYSF



Fastening in concrete

Permissible loads F_{per} in [kN] in non-cracked concrete C20/25 for single anchor without influence of spacing and edge distance, installation parameters and unit dimensions. Total safety factors as per ETAG 001 included (γ_M and γ_P). See ETA assessment for design and calculations.

Anchor studs RESI AST, VA AST Drill hole \varnothing d_0 [mm]	M8	M10	M12	M16
Anchorage depth $h_{ef,min} / h_{ef,stand} / h_{ef,max}$ [mm]	60 / 80 / 160	60 / 90 / 200	70 / 110 / 240	80 / 125 / 320

Permissible tension load ¹⁾²⁾ [24 °C / 40 °C] ³⁾ in non-cracked concrete [dry or wet]

Zinc plated 5.8	N_{per} [kN]	5,1 / 6,8 / 8,7	6,0 / 9,0 / 13,8	8,4 / 13,2 / 20,0	12,8 / 19,9 / 37,3
Stainless steel A4	N_{per} [kN]	5,1 / 6,8 / 9,8	6,0 / 9,0 / 15,5	8,4 / 13,2 / 22,5	12,8 / 19,9 / 41,9

Permissible shear load [24 °C / 40 °C] ³⁾

Zinc plated 5.8	V_{per} [kN]	5,2	8,3	12,0	22,4
Stainless steel A4	V_{per} [kN]	5,9	9,3	13,5	25,1
Permissible bending moment (Zinc plated 5.8)	M_{per} [Nm]	10,7	21,4	37,4	94,9
Permissible bending moment (Stainless steel A4)	M_{per} [Nm]	12,0	24,0	41,9	106,4

Spacing and edge distance

Spacing	$S_{cr,N}$ [mm]	180 / 240 / 480	180 / 270 / 600	210 / 330 / 720	240 / 375 / 960
Edge distance	$C_{cr,N}$ [mm]	90 / 120 / 240	90 / 135 / 300	105 / 165 / 360	120 / 188 / 480
Minimum spacing	S_{min} [mm]	40	50	60	80
Minimum edge distance	C_{min} [mm]	40	50	60	80
Min. thickness of structural part	h_{min} [mm]	$h_{ef} + 30 \text{ mm} \geq 100 \text{ mm}$			$h_{ef} + 2d_0$
Max. installation torque	$T_{inst} \leq$ [Nm]	10	20	40	80

¹⁾ Values are valid for $h_{ef,min} / h_{ef,stand} / h_{ef,max}$

²⁾ For higher concrete strengths up to C50/60 the values increase by max. 19%.

³⁾ Max. long term temperature / max. short term temperature after installation. For temperature range 50°C/80°C please see ETA assessment
If underrun the char. spacing or edge distance (C_{cr} or S_{cr}) the loads must be reduced. h_{min} , S_{min} and C_{min} must be observed.

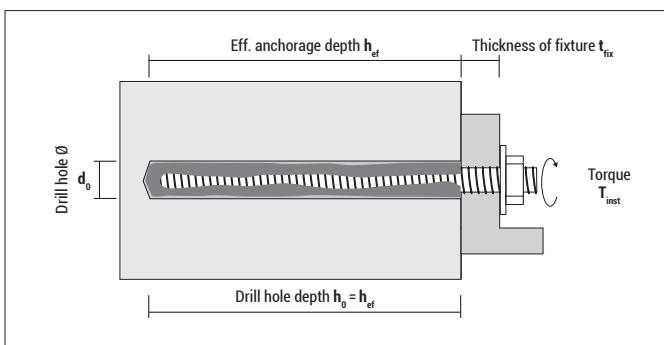

Fastening injection system ResiFIX PYSF



Fastening in masonry (Solid and hollow brick)

Permissible loads in [kN] and installation parameters - selection; for additional brick types and application conditions please see ETA assessment.

Suitable building materials	Density ρ [kg/dm ³]	Compressive strength f_b [N/mm ²]	Anchor studs RESI AST, VA AST		Min. Anchorage depth h_{ef} [mm]	Use category dry / dry 24°C/40°C ¹⁾		
			Size	Sleeve Size		Tension load N_{per} [kN]	Shear load V_{per} [kN]	
Solid sand-lime brick KS (NF)		≥ 2,0	≥ 20	M8	without / SH 12-80	80 / 80	1,29 / 1,14	1,29 / 1,14
				M10	without / SH 16-85	90 / 85	1,29 / 1,14	1,29 / 1,29
				M12	without / SH 20-85	100 / 85	1,60 / 1,14	1,43 / 1,43
				M16	without / SH 20-85	100 / 85	1,29 / 1,14	1,43 / 1,43
Solid brick Mz (DF)		≥ 1,64	≥ 20	M8	without / SH 12-80	80 / 80	0,71 / 0,86	1,29 / 1,14
				M10	without / SH 16-85	90 / 85	0,71 / 0,86	1,57 / 1,43
				M12	without / SH 20-85	100 / 85	0,57 / 0,86	2,14 / 1,43
Aerated concrete AAC4		≥ 0,50	≥ 4	M8	without	80	0,32	0,54
				M10	without	90	0,89	0,71
				M12	without	100	0,89	0,89
				M16	without	100	1,25	1,25
Hollow sand-lime brick KSL (KSL 3DF)		≥ 1,4	≥ 12	M8	SH 12-80	80	0,57	0,71
				M10	SH 16-85	85	0,57	1,00
				M10	SH 16-130	130	1,00	1,29
				M12	SH 20-85	85	0,57	1,00
Hollow brick HLz (16DF)		≥ 0,83	≥ 12	M8	SH 12-80	80	0,43	1,00
				M10	SH 16-85	85	0,71	1,71
				M10	SH 16-130	130	1,00	2,30
				M12	SH 20-85	85	1,00	1,71
M16	SH 20-85	85	1,00	1,71				

N_{per} , V_{per} : Permissible loads incl. safety factors (v_M and $v_F = 1,4$), without influence of spacing and edge distance.

Drilling method: KS and Mz: hammer drilling; Aerated concrete, KSL and HLz: rotary drilling

¹⁾Max. long term temperature / max. short term temperature. Long-term temperature is constant over a longer period of time.

The short-term temperature is only present for a short time (day/night change).

Spacing and edge distance

Suitable building materials	Anchor stud	Sleeve	Char. Edge distance c_{cr} [mm]	Min. Edge distance c_{min} [mm]	Char. Spacing parallel to the bearing joint $s_{cr,II}$ [mm]	Char. Spacing perpendicular to the bearing joint $s_{cr,I}$ [mm]	Min. Spacing s_{min} [mm]	Max. Torque T_{inst} [Nm]
Solid sand-lime brick KS (NF)	M8	without	120	120	240	240	240	10
	M10	without	135	135	270	270	270	20
	M12	without	150	150	300	300	300	20
	M16	without	150	150	300	300	300	20
Solid brick Mz (DF)	M8	without	120	120	240	240	240	6
	M10	without	135	135	270	270	270	10
	M12	without	150	150	300	300	300	10
Aerated concrete AAC4	M8	without	120	120	240	240	240	2
	M10	without	135	135	270	270	270	2
	M12	without	150	150	300	300	300	2
Hollow sand-lime brick KSL (KSL 3DF)	M8	SH 12x80	100	100	240	240	113*	8
	M10	SH 16x85	100	100	240	240	113*	8
	M10	SH 16x130	100	100	240	240	113*	8
Hollow brick HLz (16DF)	M12,M16	SH 20x85	120	120	240	240	113*	8
	M8	SH 12x80	100	100	497	497	238**	6
	M10	SH 16x85	100	100	497	497	238**	6
	M10	SH 16x130	100	100	497	497	238**	6
M12,M16	SH 20x85	120	120	497	497	238**	6	

Permissible bending moment

Steel		Anchor stud			
		M8	M10	M12	M16
Zinc plated 5.8	M_{per} [Nm]	10,9	21,1	37,1	94,9
Stainless steel A4	M_{per} [Nm]	11,9	23,8	42,1	106,2

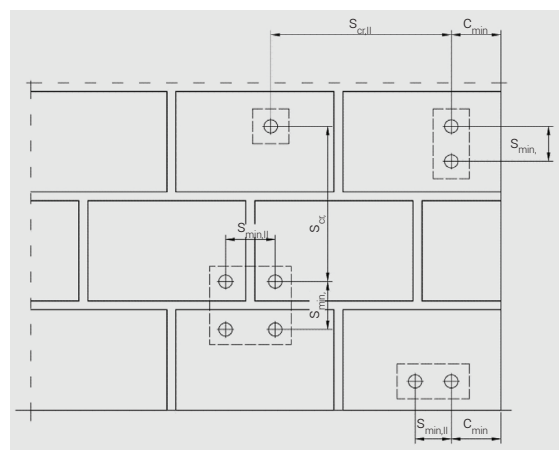

* Values are valid for $s_{min,I}$. For $s_{min,II}$ 240 mm is valid.

** Values are valid for $s_{min,I}$. For $s_{min,II}$ 497 mm is valid.

Fastening injection system

ResiFIX

Pure Epoxy Plus EPP SF



Approvals and certificates



European Technical Assessment
Option 1 for cracked concrete
(M8 - M30, Ø8 - Ø32)



European Technical Assessment
for post-installed rebar
connections (Ø8 - Ø40)



Approved for anchor rods and reinforced steel bars

- **Various applications**



Service life of the product: 100 years based on the ETA

- **Long-lasting and safe**



Class A+: Lowest emissions of critical substances in closed spaces

- **Harmless to health after curing**



Sustainability certification LEED

- **Environmentally friendly, low-pollutant, low-emission and sustainable construction product**



Usage under seismic conditions

- **Tested for use in areas with high risk of earthquakes**



European Technical Assessment Option 1 for cracked and non-cracked concrete (M8 - M30)

- **For a wide range of safety critical applications**



Diamond drilling is approved

- **Premium product**



One mixing nozzle and one extension tube are always included

- **Deeper drill holes can also be filled**



M12-110mm
C20/25

Very high load values

- **Heavy-duty usage**



Usage also in water-filled drill holes and suitable for contact with drinking water

- **Extended range of applications**



Fire resistance report R120

- **Fulfills fire protection requirements**



(Ø8 - Ø40)

European Technical Assessment post-installed rebar connections (Ø8 - Ø40)

- **For more application flexibility**



Styrene free

- **Reduced odour exposure**



Pure Epoxy EPP SF (styrene free)

Type	Art-No	Content [ml]	Mixings nozzles included [pcs]	Mixings nozzle extension [200mm] incl. [pcs]	Shelf life [months]		€ / pc	[pcs]
EPP 440 SF *	440EPPSF	385	1	1	24	●		12
EPP 585 SF ¹⁾	585EPPSF	585	1	1	24	●		12
EPP 1400 SF *	1400EPPSF	1400	1	1	24	●		12

* Delivery time on request

¹⁾ Delivery quantity on request

Curing times ResiFIX Pure Epoxy EPP SF

Temperature of building material [°C]	> -10	> -5	> 0	> +5	> +10	> +15	> +20	> +25	> +35	> +40
Max. working time [min]	–	–	90	80	60	40	30	12	8	8
Min. curing time ¹⁾ [min]	–	–	144h	48h	28h	18h	12h	9h	6h	4h

¹⁾ Double curing time in wet concrete

Fastening in concrete

Permissible loads F_{per} in [kN] for a service life of 50 years in non-cracked concrete C20/25 (Option 7) and cracked concrete C20/25 (Option 1) without influence of edge distances and spacing ($c \geq 10 \times h_{ef}$ or 60 d , $s \geq 3 \times h_{ef}$, $h \geq 2 \times h_{ef}$) as well as installation parameters and unit dimensions. F_{per} includes the partial safety factors for the resistance from the ETA and a partial safety factor for the actions of $\gamma F = 1.4$. The ETA assessment must be observed in the design.

Anchor studs RESI AST, VA AST	M8	M10	M12	M16	M20	M24	M 27	M30
Drill hole Ø d_0 [mm]	10	12	14	18	22	28	30	35
Anchorage depth $h_{ef,min} / h_{ef,stand} / h_{ef,max}$ [mm]	60 / 80 / 160	60 / 90 / 200	70 / 110 / 240	80 / 125 / 320	90 / 170 / 400	96 / 210 / 480	108 / 240 / 540	120 / 280 / 600

Permissible tension load ¹⁾²⁾ [24 °C / 40 °C] ³⁾ in non-cracked concrete (dry or wet)

Zinc plated 5.8	N_{zul} [kN]	8,7	10,9 / 13,8 / 13,8	13,7 / 20,1 / 20,1	16,8 / 32,7 / 37,3	20,0 / 51,9 / 58,3	22,0 / 71,3 / 83,9	26,3 / 87,1 / 109,4	30,8 / 109,8 / 133,5
Stainless steel A4 ⁴⁾	N_{zul} [kN]	9,8	10,9 / 15,5 / 15,5	13,7 / 22,5 / 22,5	16,8 / 32,7 / 41,9	20,0 / 51,9 / 65,5	22,0 / 71,3 / 94,2	26,3 / 57,4 / 57,4	30,8 / 70,0 / 70,0

Permissible tension load ¹⁾²⁾ [24 °C / 40 °C] ³⁾ in cracked concrete (dry or wet)

Zinc plated 5.8	N_{zul} [kN]	5,0 / 6,7 / 8,7	6,3 / 9,4 / 13,8	9,6 / 16,8 / 20,1	11,7 / 22,9 / 37,3	14,0 / 36,3 / 58,3	15,4 / 49,9 / 83,9	18,4 / 61,0 / 109,4	21,6 / 76,8 / 133,5
Stainless steel A4 ⁴⁾	N_{zul} [kN]	5,0 / 6,7 / 9,8	6,3 / 9,4 / 15,5	9,6 / 16,8 / 22,5	11,7 / 22,9 / 41,9	14,0 / 36,3 / 65,5	15,4 / 49,9 / 94,2	18,4 / 57,4 / 57,4	21,6 / 70,0 / 70,0

Permissible tension load ¹⁾²⁾ [50 °C / 72 °C] ³⁾ in non-cracked concrete (dry or wet)

Zinc plated 5.8	N_{zul} [kN]	8,7	10,9 / 13,8 / 13,8	13,7 / 20,1 / 20,1	16,8 / 32,7 / 37,3	20,0 / 51,9 / 58,3	22,0 / 71,3 / 83,9	26,3 / 87,1 / 109,4	30,8 / 109,8 / 133,5
Stainless steel A4 ⁴⁾	N_{zul} [kN]	9,8	10,9 / 15,5 / 15,5	13,7 / 22,5 / 22,5	16,8 / 32,7 / 41,9	20,0 / 51,9 / 65,5	22,0 / 71,3 / 94,2	26,3 / 57,4 / 57,4	30,8 / 70,0 / 70,0

Permissible tension load ¹⁾²⁾ [50 °C / 72 °C] ³⁾ in cracked concrete (dry or wet)

Zinc plated 5.8	N_{zul} [kN]	4,3 / 5,7 / 8,7	6,3 / 9,4 / 13,8	8,8 / 13,8 / 20,1	11,7 / 20,9 / 37,3	14,0 / 35,6 / 58,3	15,4 / 49,9 / 83,9	18,4 / 61,0 / 109,4	21,6 / 76,8 / 133,5
Stainless steel A4 ⁴⁾	N_{zul} [kN]	4,3 / 5,7 / 9,8	6,3 / 9,4 / 15,5	8,8 / 13,8 / 22,5	11,7 / 20,9 / 41,9	14,0 / 35,6 / 65,5	15,4 / 49,9 / 94,2	18,4 / 57,4 / 57,4	21,6 / 70,0 / 70,0

Permissible shear load ¹⁾ in non-cracked concrete

Zinc plated 5.8	V_{zul} [kN]	5,2	8,3	12,0	22,4	35,0	44,1 / 50,4 / 50,4	52,6 / 65,6 / 65,6	61,6 / 80,1 / 80,1
Stainless steel A4 ⁴⁾	V_{zul} [kN]	5,9	9,3	13,5	25,1	39,2	44,1 / 56,5 / 56,5	52,6 / 52,6 / 52,6	61,6 / 64,2 / 64,2

Permissible shear load ¹⁾ in cracked concrete

Zinc plated 5.8	V_{zul} [kN]	5,2	8,3	12,0	22,4 / 22,4 / 22,4	28,0 / 35,0 / 35,0	30,8 / 50,4 / 50,4	36,8 / 65,6 / 65,6	43,1 / 80,1 / 80,1
Stainless steel A4 ⁴⁾	V_{zul} [kN]	5,9	9,3	13,5	23,5 / 25,1 / 25,1	28,0 / 39,2 / 39,2	30,8 / 56,5 / 56,5	36,8 / 52,6 / 52,6	43,1 / 64,2 / 64,2

Permissible bending moment	M_{zul} [Nm]	10,7	21,4	37,4	94,9	185,2	320,0	476,2	642,1
Zinc plated 5.8									
Permissible bending moment	M_{zul} [Nm]	12,0	24,0	41,9	106,4	207,8	359,0	249,7	337,6
Stainless steel A4 ⁴⁾									

Spacing and edge distance

Spacing	$s_{cr,N}$ [mm]	180 / 240 / 480	180 / 270 / 600	210 / 330 / 720	240 / 375 / 960	270 / 510 / 1200	288 / 630 / 1440	324 / 720 / 1620	360 / 840 / 1800
Edge distance	$c_{cr,N}$ [mm]	90 / 120 / 240	90 / 135 / 300	105 / 165 / 360	120 / 188 / 480	135 / 255 / 600	144 / 315 / 720	162 / 360 / 810	180 / 420 / 900
Minimum spacing	s_{min} [mm]	40	50	60	75	95	155	125	140
Minimum edge distance	c_{min} [mm]	35	40	45	50	60	65	75	80
Min. thickness of concrete	h_{min} [mm]	$h_{ef} + 30 \text{ mm} \geq 100 \text{ mm}$				$h_{ef} + 2d_0$			
Max. installation torque	$T_{inst} \leq$ [Nm]	10	20	40	60	100	170	250	300

Characteristic loads F_{char} in [kN] for a service life of 100 years please refer to the ETA.

The load values apply to hammer-drilled and compressed air-drilled holes (for hollow drill bits and diamond-drilled holes see ETA).

1) Values apply to $h_{ef,min} / h_{ef,stand} / h_{ef,max}$

2) Increase factor for cracked and non-cracked concrete C25/30=1.02, C30/37 = 1.04, C35/45 = 1.07, C40/50 = 1.08, C45/55 = 1.09, C50/60 = 1.10

3) Max. Long-term temperature / max. short-term temperature in installed condition.

4) Stainless steel A4: M8-M24: Class 70, M27 and M30: Class 50

The load capacity must be reduced if the char. edge/spacing distance (C_{cr} or S_{cr}) is not reached. h_{min} , S_{min} and C_{min} must be observed

Fastening injection system

ResiFIX

Pure Epoxy

EP SF



Approvals and certificates



Approved for anchor rods and reinforced steel bars

- **Various applications**



Class A+: Lowest emissions of critical substances in closed spaces

- **Harmless to health after curing**



Sustainability certification LEED

- **Environmentally friendly, low-pollutant, low-emission and sustainable construction product**



European Technical Assessment Option 1 for cracked and non-cracked concrete (M8 - M30)

- **For a wide range of safety critical applications**



One mixing nozzle and one extension tube are always included

- **Deeper drill holes can also be filled**



Diamond drilling is approved (only for post-installed rebar connections)

- **Premium product**



M12-110mm C20/25

Very high load values

- **Heavy-duty usage**



Usage also in water-filled drill holes

- **Extended range of applications**



Fire resistance report R240

- **Valid only for post installed rebar connections**



(Ø8 - Ø40)

European Technical Assessment post-installed rebar connections

- **For more application flexibility**



Styrene free

- **Reduced odour exposure**



Pure Epoxy EP SF (styrene free)

Type	Art-No	Content [ml]	Mixings nozzles included [pcs]	Mixings nozzle extension (200mm) incl. [pcs]	Shelf life [months]		€ / pc	[pcs]
EP 440 SF *	440EPSF	440	1	1	24	●		12
EP 585 SF ¹⁾	585EPSF	585	1	1	24	●		12

*Delivery time on request

¹⁾ Delivery quantity on request

Curing times ResiFIX Pure Epoxy EP SF

Temperature of building material [°C]	> -10	> -5	> 0	> +5	> +10	> +15	> +20	> +25	> +35	> +40
Max. working time [min]	–	–	–	80	60	40	30	12	8	8
Min. curing time ¹⁾ [min]	–	–	–	60h	48h	24h	12h	10h	7h	4h

¹⁾ Double curing time in wet concrete

Fastening in concrete

Permissible loads F_{per} in [kN] in non-cracked concrete C20/25 (Option 7) and cracked concrete C20/25 (Option 1) without influence of edge distances and spacing ($c \geq 10 \times h_{ef}$ or 60 d, $s \geq 3 \times h_{ef}$, $h \geq 2 \times h_{ef}$) as well as installation parameters and unit dimensions. F_{per} includes the partial safety factors for the resistance from the ETA and a partial safety factor for the actions of $\gamma_F = 1.4$. The ETA assessment must be observed in the design.

Anchor studs RESI AST, VA AST	M8	M10	M12	M16	M20	M24	M 27	M30
Drill hole \varnothing d_0 [mm]	10	12	14	18	24	28	30	35
Anchorage depth $h_{ef,min} / h_{ef,stand} / h_{ef,max}$ [mm]	60 / 80 / 160	60 / 90 / 200	70 / 110 / 240	80 / 125 / 320	90 / 170 / 400	96 / 210 / 480	108 / 240 / 540	120 / 280 / 600

Permissible tension load ¹⁾²⁾ (24 °C / 40 °C) ³⁾ in non-cracked concrete (dry, wet or waterfilled)

	N_{zul} [kN]	M8	M10	M12	M16	M20	M24	M 27	M30
Zinc plated 5.8		7,7 / 8,7 / 8,7	7,8 / 13,8 / 13,8	9,8 / 19,3 / 20,1	12,0 / 23,4 / 37,3	14,3 / 37,1 / 58,3	15,7 / 50,9 / 83,9	18,8 / 62,2 / 109,4	22,0 / 78,4 / 133,5
Stainless steel A4 ⁴⁾		7,7 / 9,8 / 9,8	7,8 / 14,3 / 15,5	9,8 / 19,3 / 22,5	12,0 / 23,4 / 41,9	14,3 / 37,1 / 65,5	15,7 / 50,9 / 94,2	18,8 / 57,4 / 57,4	22,0 / 70,0 / 70,0

Permissible tension load ¹⁾²⁾ (24 °C / 40 °C) ³⁾ in cracked concrete (dry, wet or waterfilled)

	N_{zul} [kN]	M8	M10	M12	M16	M20	M24	M 27	M30
Zinc plated 5.8		3,6 / 4,8 / 8,7	4,5 / 6,7 / 13,8	6,3 / 9,9 / 20,1	8,4 / 15,0 / 37,3	10,0 / 25,4 / 58,3	11,0 / 32,3 / 73,9	13,1 / 41,5 / 93,5	15,4 / 53,9 / 115,4
Stainless steel A4 ⁴⁾		3,6 / 4,8 / 9,6	4,5 / 6,7 / 15,0	6,3 / 9,9 / 20,1	8,4 / 15,0 / 38,3	10,0 / 25,4 / 59,8	11,0 / 32,3 / 73,9	13,1 / 41,5 / 57,4	15,4 / 53,9 / 70,0

Permissible tension load ¹⁾²⁾ (43 °C / 70 °C) ³⁾ in non-cracked concrete (dry, wet or waterfilled)

	N_{zul} [kN]	M8	M10	M12	M16	M20	M24	M 27	M30
Zinc plated 5.8		3,6 / 4,8 / 8,7	4,5 / 6,7 / 13,8	6,3 / 9,9 / 20,1	8,9 / 13,9 / 35,6	12,5 / 23,6 / 55,6	14,8 / 32,3 / 73,9	18,7 / 41,5 / 93,5	22,0 / 53,9 / 115,4
Stainless steel A4 ⁴⁾		3,6 / 4,8 / 9,6	4,5 / 6,7 / 15,0	6,3 / 9,9 / 21,5	8,9 / 13,9 / 35,6	12,5 / 23,6 / 55,6	14,8 / 32,3 / 73,9	18,7 / 41,5 / 57,4	22,0 / 53,9 / 70,0

Permissible tension load ¹⁾²⁾ (43 °C / 70 °C) ³⁾ in cracked concrete (dry, wet or waterfilled)

	N_{zul} [kN]	M8	M10	M12	M16	M20	M24	M 27	M30
Zinc plated 5.8		1,8 / 2,4 / 4,8	2,2 / 3,4 / 7,5	3,1 / 4,9 / 10,8	4,8 / 7,5 / 19,1	6,7 / 12,7 / 29,9	7,4 / 16,2 / 36,9	9,3 / 20,8 / 46,7	11,5 / 26,9 / 57,7
Stainless steel A4 ⁴⁾		1,8 / 2,4 / 4,8	2,2 / 3,4 / 7,5	3,1 / 4,9 / 10,8	4,8 / 7,5 / 19,1	6,7 / 12,7 / 29,9	7,4 / 16,2 / 36,9	9,3 / 20,8 / 46,7	11,5 / 26,9 / 57,7

Permissible shear load ¹⁾ in non-cracked concrete

	V_{zul} [kN]	M8	M10	M12	M16	M20	M24	M 27	M30
Zinc plated 5.8		5,2	8,3	12,0	22,4	35,0	44,1 / 50,4 / 50,4	52,6 / 65,6 / 65,6	61,6 / 80,1 / 80,1
Stainless steel A4 ⁴⁾		5,9	9,3	13,5	25,1	39,2	44,1 / 56,5 / 56,5	52,6 / 52,6 / 52,6	61,6 / 64,2 / 64,2

Permissible shear load ¹⁾ in cracked concrete

	V_{zul} [kN]	M8	M10	M12	M16	M20	M24	M 27	M30
Zinc plated 5.8		5,2	8,3	12,0	22,4 / 22,4 / 22,4	28,0 / 35,0 / 35,0	30,8 / 50,4 / 50,4	36,8 / 65,6 / 65,6	43,1 / 80,1 / 80,1
Stainless steel A4 ⁴⁾		5,9	9,3	13,5	23,5 / 25,1 / 25,1	28,0 / 39,2 / 39,2	30,8 / 56,5 / 56,5	36,8 / 52,6 / 52,6	43,1 / 64,2 / 64,2

Permissible bending moment (Zinc plated 5.8)	M_{zul} [Nm]	M8	M10	M12	M16	M20	M24	M 27	M30
		10,7	21,4	37,4	94,9	185,2	320,0	476,2	642,1
Permissible bending moment (Stainless steel A4 ⁴⁾)	M_{zul} [Nm]	12,0	24,0	41,9	106,4	207,8	359,0	249,7	337,6

Spacing and edge distance

Spacing	$s_{cr,N}$ [mm]	M8	M10	M12	M16	M20	M24	M 27	M30	
Spacing		180 / 240 / 480	180 / 270 / 600	210 / 330 / 720	240 / 375 / 960	270 / 510 / 1200	288 / 630 / 1440	324 / 720 / 1620	360 / 840 / 1800	
Edge distance	$c_{cr,N}$ [mm]	90 / 120 / 240	90 / 135 / 300	105 / 165 / 360	120 / 188 / 480	135 / 255 / 600	144 / 315 / 720	162 / 360 / 810	180 / 420 / 900	
Minimum spacing	s_{min} [mm]	40	50	60	75	95	115	125	140	
Minimum edge distance	c_{min} [mm]	35	40	45	50	60	65	75	80	
Min. thickness of concrete	h_{min} [mm]	$h_{ef} + 30 \text{ mm} \geq 100 \text{ mm}$				$h_{ef} + 2d_0$				
Max. installation torque	$T_{mst} \leq$ [Nm]	10	20	40	60	100	170	250	300	

The load values apply to hammer-drilled and compressed air-drilled holes and in hammer-drilled holes with a hollow drill bit.

¹⁾ Values apply to $h_{ef,min} / h_{ef,stand} / h_{ef,max}$

²⁾ Increase factor for cracked and non-cracked concrete C25/30=1,02, C30/37 = 1,04, C35/45 = 1,07, C40/50 = 1,08, C45/55 = 1,09, C50/60 = 1,10

³⁾ Max. Long-term temperature / max. short-term temperature in installed condition. For temperature range 35°/60°C see ETA.

⁴⁾ Stainless steel A4: M8-M24: Class 70, M27 and M30: Class 50

The load capacity must be reduced if the char. edge/spacing distance (C_{cr} or S_{cr}) is not reached. h_{min} , S_{min} and C_{min} must be observed.

ResiFIX Manual dispenser



APP300



- High force transmission of 1:25 and so **noticeably reduced force expenditure**
- **Robust manual dispenser** made out of metal
- Also suitable for **all standard cartridges**, e.g. commercial adhesives and sealants (silicone, MS Polymer)
- Reduced weight - **improved working comfort**
- **The cartridge area is rotatable 360°** which facilitates the usage of sealants especially in corners

Manual dispenser APP 300

Type	Art-No	Suitable for ResiFIX Type	€ / pc	[pcs]
APP 300	300APP	300 / 165 / 280		1



APVM



- High force transmission of 1:25 and so **noticeably reduced force expenditure**
- **Robust manual dispenser** made out of metal
- Low weight due to the use of magnesium **only 680 g light**; therefore increased working comfort
- Suitable for **side-by-side cartridges with 345 ml content**. Also suitable for standard cartridges with 165 ml, 280 ml, 300 ml to read the scale units of ResiFIX; outer rod serves as a pointer

Manual dispenser APVM

Type	Art-No	Suitable for ResiFIX Type	€ / pc	[pcs]
APVM	345APVM	345 / 300 / 280 / 165		1



APP380



- High force transmission of 1:25 and so **noticeably reduced force expenditure**
- **Robust manual dispenser** made out of metal
- Suitable for **ResiFIX cartridges with 410 ml**

Manual dispenser APP 380

Type	Art-No	Suitable for ResiFIX Type	€ / pc	[pcs]
APP 380	380APP	410		1



OL385



Manual dispenser OL for ResiFIX Pure Epoxy

Type	Art-No	Suitable for ResiFIX Type	€ / pc	[pcs]
OL 385	385OL	440 / 585		1



Mixing nozzle MD transparent

Type	Art-No	Suitable cartridges	€ / pc	[pcs]	[pcs]
MD	9MRMEA	all, except Pure Epoxy		20	-
MDE	9MRE	only for Pure Epoxy		10	-



Mixings nozzle extension MDV for MD

Type	Art-No	Outer Ø [mm]	Length [mm]	€ / pc	[pcs]	[pcs]
MDV 7,5*	975MDV	7,5	200		10	-
MDV 10	9MDV	10	200		10	-
MDV 10x500	910500MDV	10	500		10	-

* Especially suitable for metal sleeve SH 12-100 (see page 199)



Cleaning brush RBK made of nylon, for masonry (with wooden handle)

Type	Art-No	Length [mm]	Suitable for hole-Ø [mm]	€ / pc	[pcs]	[pcs]
RBK Ø20	9PLRBK	300	20		5	-

Not part of the ETA assessment



Cleaning brush RBS made of steel, for concrete

Type	Art-No	Length [mm]	Brush-Ø [mm]	Suitable for drill hole-Ø [mm]	Suitable for anchor stud	Connecting thread	€ / pc	[pcs]	[pcs]
RBS10	9M12RBK	170	12	10	M8	M6		5	-
RBS12	9M14RBK	170	14	12	M10	M6		5	-
RBS14	9M16RBK	200	16	14	M12	M6		5	-
RBS18	9M20RBK	200	20	18	M16	M6		5	-
RBS24	9M26RBK	250	26	24	M20	M6		5	-
RBS28	9M30RBK	300	30	28	M24	M6		5	-



Handle and Extension for RBS

Type	Art-No	Length [mm]	Suitable for RBS Ø	Connecting thread	€ / pc	[pcs]	[pcs]
MRBKV	MRBKV	140	all	M6		5	-
MRBKH	MRBKH	-	all	M6		5	-



Blow out pump AB



Type	Art-No	Tube-Ø [mm]	€ / pc	[pcs]	[pcs]
AB	BOP	8		1	-



Heavy-duty sleeve ResiTHERM® 37S M12 for non-insulated hollow brick walls

Type	Art-No	Set contains (packed in bag)	L _d [mm]	ETA	€ / Set	[Set]	[Sets]
RTH S	RTHS2	2x ResiTHERM® 37S M12 2x Threaded stud M12x70 mm, stainless steel A4 2x Washer M12 DIN 125, stainless steel A4 2x Hexagon nut M12 DIN 934, stainless steel A4 1x ResiFIX VY300SF incl. 2 mixing nozzles MD	125	●		1	10

ResiFIX sleeves

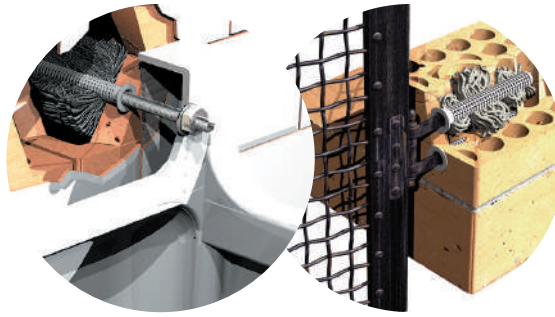

Plastic sleeves SH

Type	Art-No	d ₀ [mm]	L _d [mm]	h ₀ [mm]	Suitable for thread Ø	€/ 100 pcs	[pcs]	[pcs]
SH 12x60 ¹⁾	91260SH	12	60	65	M6, M8		24	432
SH 12x80	91280SH	12	80	85	M6, M8		24	432
SH 16x85	91585SH	16	85	90	M8, M10		12	216
SH 16x130	915130SH	16	130	135	M8, M10		12	144
SH 20x85	92085SH	20	85	90	M12, M16		12	216
SH 20x130	920130SH	20	130	135	M12, M16		20	160
SH 20x200	920200SH	20	200	205	M12, M16		20	160

Note: The system (resin, sleeve and anchor rod) is only approved completely if approved components are used.

1) Not part of the ResiFIX ETA assessments



Blister SH



Type	Art-No	d ₀ [mm]	h ₀ [mm]	Suitable for thread Ø	€/ Blister	[pcs]	[Blister]
SH 12x80	51280SH4	12	85	M6, M8		4	10
SH 16x85	51685SH4	16	90	M8, M10		4	10
SH 16x130	515130SH4	16	135	M8, M10		4	10
SH 20x85	52085SH4	20	90	M12, M16		4	10

Note: The system (resin, sleeve and anchor rod) is only approved completely if approved components are used.

Metal sleeves SH-1000 can be cut individually (length 1m)

Type	Art-No	d ₀ [mm]	h ₀ [mm]	Suitable for thread Ø	€/ pcs	[pcs]	[pcs]
SH 12x1000	12TMRMEA	12	flexible	M6 – M8		10	–
SH 16x1000	16TMRMEA	16	flexible	M8 – M12		10	–
SH 22x1000	22TMRMEA	22	flexible	M12 – M16		8	–



Internal threaded sleeves IGH

Type	Art-No	d ₀ [mm]	h ₀ [mm]	Suitable for thread Ø	Thread L* [mm]	Outer Ø [mm]	Suitable for sleeve	€/ 100 pcs	[pcs]	[pcs]
IGH M8x80	9880IGH	14	90	M8	26	12	SH 16x85 SH 20x85		12	324
IGH M10x80	91080IGH	16	90	M10	26	14	SH 20x85		12	324
IGH M12x80	91280IGH	18	90	M12	26	16	SH 20x85		12	324

*Internal thread length



Blister IGH



Type	Art-No	d ₀ [mm]	h ₀ [mm]	Suitable for thread Ø	Outer Ø [mm]	€/ Blister	[pcs]	[Blister]
IGH M8x80	5880IGHM4	14	90	M8	12		4	10
IGH M10x80	51080IGHM4	16	90	M10	14		4	10

ResiFIX Anchor studs

Approvals and certificates

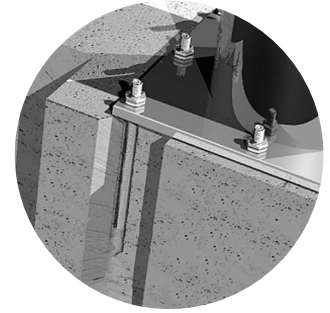

RESI AST, zinc plated 5.8 with nut and washer

Type d _s x L	Art-No	in concrete					in solid brick		in hollow brick		€/100 pcs	[pcs]	[pcs]
		d ₀ [mm]	h _{ef, min} [mm]	t _{fix, max} for h _{ef, min} [mm]	h _{ef, Stand} ¹⁾ [mm]	t _{fix, max} for h _{ef, stand} [mm]	d ₀ - h ₀ [mm]	t _{fix, max} [mm]	Sleeve [Type]	t _{fix, max} [mm]			
M8x110	98110RAST	10	60	40	80	20	10 - 80	20	SH 12x80	20	10	100	
M8x130	98130RAST	10	60	60	80	40	10 - 80	40	SH 12x80	40	10	100	
M10x110	910110RAST	12	60	40	90	10	12 - 90	10	SH 16x85	15	10	100	
M10x130	910130RAST	12	60	60	90	30	12 - 90	30	SH 16x85	35	10	100	
M10x170	910170RAST	12	60	100	90	70	12 - 90	70	SH 16x85	75	10	100	
M10x200	910200RAST	12	60	130	90	100	12 - 90	100	SH 16x85	105	10	60	
M12x130	912130RAST	14	70	45	110	5	14 - 100	15	SH 20x85	30	10	100	
M12x160	912160RAST	14	70	75	110	35	14 - 100	45	SH 20x85	60	10	100	
M12x210	912210RAST	14	70	125	110	85	14 - 100	95	SH 20x85	110	10	60	
M16x160	916160RAST	18	80	60	125	15	18 - 100	40	SH 20x85	60	10	60	
M16x190	916190RAST	18	80	90	125	45	18 - 100	70	SH 20x85	90	10	60	
M16x235	916235RAST	18	80	135	125	90	18 - 100	115	SH 20x85	135	10	40	
M20x240	920240RAST	24	90	130	170	50	not suitable		not suitable		5	20	
M24x300	924300RAST	28	96	180	210	65	not suitable		not suitable		5	20	



RESI AST, stainless steel A4 with nut and washer



Type d _s x L	Art-No	in concrete					in solid brick		in hollow brick		€/100 pcs	[pcs]	[pcs]
		d ₀ [mm]	h _{ef, min} [mm]	t _{fix, max} for h _{ef, min} [mm]	h _{ef, Stand} ¹⁾ [mm]	t _{fix, max} for h _{ef, stand} [mm]	d ₀ - h ₀ [mm]	t _{fix, max} [mm]	Sleeve [Type]	t _{fix, max} [mm]			
M8x110	9X8110RAST	10	60	40	80	20	10 - 80	20	SH 12x80	20	10	100	
M8x130	9X8130RAST	10	60	60	80	40	10 - 80	40	SH 12x80	40	10	100	
M10x110	9X10110RAST	12	60	40	90	10	12 - 90	10	SH 16x85	15	10	100	
M10x130	9X10130RAST	12	60	60	90	30	12 - 90	30	SH 16x85	35	10	100	
M10x170	9X10170RAST	12	60	100	90	70	12 - 90	70	SH 16x85	75	10	100	
M10x200	9X10200RAST	12	60	130	90	100	12 - 90	100	SH 16x85	105	10	60	
M12x130	9X12130RAST	14	70	45	110	5	14 - 100	15	SH 20x85	30	10	100	
M12x160	9X12160RAST	14	70	75	110	35	14 - 100	45	SH 20x85	60	10	100	
M12x210	9X12210RAST	14	70	125	110	85	14 - 100	95	SH 20x85	110	10	60	
M16x160	9X16160RAST	18	80	60	125	15	18 - 100	40	SH 20x85	60	10	60	
M16x190	9X16190RAST	18	80	90	125	45	18 - 100	70	SH 20x85	90	10	60	
M16x235	9X16235RAST	18	80	135	125	90	18 - 100	115	SH 20x85	135	10	40	
M20x240	9X20240RAST	24	90	130	170	50	not suitable		not suitable		5	20	
M24x300	9X24300RAST	28	96	180	210	65	not suitable		not suitable		5	20	

Also suitable for ResiFIX: Anchor studs VA AST for the bonded anchor (with outer hexagon)

Further lengths, steel 8.8, hot-dip galvanized steel and stainless steel HCR on request

1) Standard anchorage depth means the usually used anchorage depth. Min. anchorage depth according to ETA assessment



Blister RESI AST, zinc plated



Type	Art-No	Thread	Length L [mm]	€/Blister	[pcs]	[Blister]
8x110	58110VMAST4	M8	110		4	10
10x130	510130VMAST4	M10	130		4	10
12x160	512160VMAST4	M12	160		4	10

Note: The system (resin, sleeve and anchor rod) is only approved completely if approved components are used.

Bonded anchor VA



Advantages



Bonded anchor VA



Anchor stud VA AST

- Suitable for fastening heavy loads in concrete with small edge distances
- The VA bonded anchor utilises the joint between the steel, the mortar and the concrete
- During installation the glass tube is crushed and mixes with the resin, hardener and the aggregates
- The bonded anchor VA made of two components contains styrene free vinylester resin
- Long shelf life of min. 2.5 years
- Anchor stud VA AST: Every box includes a setting tool

Approvals and certificates

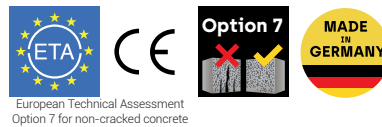

Mounting

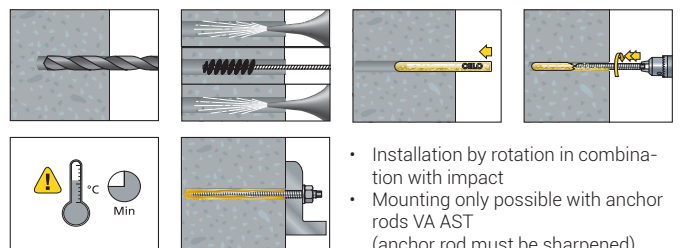

- Installation by rotation in combination with impact
- Mounting only possible with anchor rods VA AST (anchor rod must be sharpened)
- Higher loads are achieved by premium cleaning (For details see ETA assessment)
- Assortment see page 198

Suitable building materials

Very suitable



- Concrete



Suitable to a limited extent

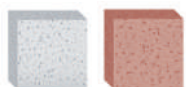

- Dense natural stone
- Solid brick
- Solid sand-lime brick

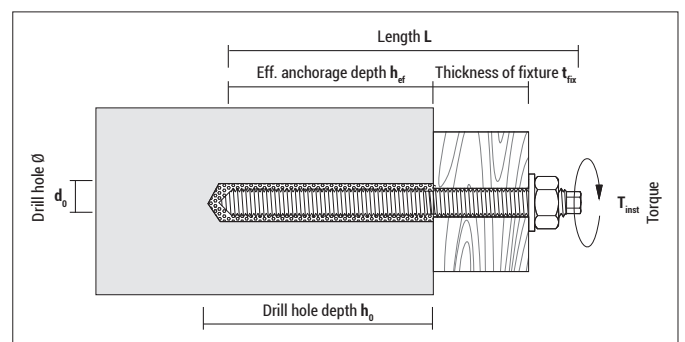

CELO



VA

Type	Art-No	d ₀ [mm]	h ₀ [mm]	Suitable for VA AST		€/100 pcs	[pcs]	[pcs]
VA M8	98VA	10	80	M8	●		10	200
VA M10	910VA	12	90	M10	●		10	200
VA M12	912VA	14	110	M12	●		10	200
VA M16	916VA	18	125	M16	●		10	200
VA M20	920VA	25	170	M20	●		5	50
VA M24	924VA	28	210	M24	●		5	50



VA AST, zinc plated 5.8 with nut, washer and hex-head

Type d _s x L	Art-No	d ₀ [mm]	h _{ef} =h ₀ [mm]	L [mm]	t _{fix} ≤ [mm]	Nut		€/100 pcs	[pcs]	[pcs]
M8x110	98100AST	10	80	110	16	SW 13	●		10	100
M10x130	910130AST	12	90	130	22	SW 17	●		10	100
M10x165	910165AST	12	90	165	58	SW 17	●		10	100
M10x190	910190AST	12	90	190	82	SW 17	●		10	60
M12x160	912160AST	14	110	160	30	SW 19	●		10	100
M12x220	912220AST	14	110	220	90	SW 19	●		10	40
M12x250	912250AST	14	110	250	120	SW 19	●		10	40
M12x300	912300AST	14	110	300	170	SW 19	●		10	40
M16x165	916165AST	18	125	165	13	SW 24	●		10	60
M16x190	916190AST	18	125	190	38	SW 24	●		10	60
M16x250	916250AST	18	125	250	98	SW 24	●		10	40
M20x260	920260AST	25	170	260	70	SW 30	●		5	20
M24x300	924300AST	28	210	300	65	SW 36	●		5	20
M30x380 *	930380AST	35	280	380	70	SW 46	—		5	—

* without hexagon head

Every box contains a setting tool.



VA AST, stainless steel A4 with nut, washer and hex-head

Type	Art-No	d ₀ [mm]	h _{ef} =h ₀ [mm]	L [mm]	t _{fix} ≤ [mm]	Nut		€/100 pcs	[pcs]	[pcs]
M8x110	9X8100AST	10	80	110	16	SW 13	●		10	100
M10x130	9X10130AST	12	90	130	22	SW 17	●		10	100
M12x160	9X12160AST	14	110	160	30	SW 19	●		10	100
M16x190	9X16190AST	18	125	190	38	SW 24	●		10	60

Every box contains a setting tool.

Loads, spacing and edge distance in non-cracked concrete, max. temperature 50/80 °C

Type	Non-cracked concrete C20/25 ^{1) 2) 3)}				Bending moment		Spacing ⁵⁾		Edge distance ⁵⁾		Min. thickness of structural part h _{min} [mm]	Max. Torque T _{inst} ≤ [Nm]
	Tension load standard cleaning N _{per} [kN]	Tension load premium cleaning ⁴⁾ N _{per} [kN]	Shear load zinc plated V _{per} [kN]	Shear load A4 V _{per} [kN]	zinc plated M _{per} [Nm]	A4 M _{per} [Nm]	S _{cr} [mm]	S _{min} [mm]	C _{cr,N} [mm]	C _{min} [mm]		
M8	3,6	4,8	4,4	5,0	8,8	10,1	240	60	120	60	110	10
M10	4,8	6,4	7,1	7,8	16,5	18,8	270	70	135	70	120	20
M12	6,4	9,9	10,4	11,9	30,8	34,3	330	85	165	85	150	40
M16	9,9	13,9	19,8	22,4	79,1	88,8	380	95	190	95	160	60
M20	15,9	23,8	31,3	35,3	156,6	175,8	510	130	255	130	220	120
M24	23,8	29,8	45,6	50,8	273,6	306,6	630	160	315	160	300	150

¹⁾ Permissible loads for single anchor without influence of spacing and edge distance.

²⁾ Load figures include the resistances' partial safety factors as per ETA assessment and a partial safety factor on the action of v_F = 1,4.

³⁾ For higher concrete strengths up to C50/60 the values increase by max. 19%.

⁴⁾ Premium cleaning: For details see ETA assessment.

⁵⁾ If underrun the char. spacing or edge distance (C_{cr} or S_{cr}) the loads must be reduced. h_{min}, S_{min} and C_{min} must be observed.

Curing times in dry concrete

Temperature inside drill hole	[°C]	> 0	> +5	> +10	> +20
Min. curing time	[min]	180	90	40	20

Installation possible in dry or wet concrete.

Installation for anchor sizes M12 to M24 possible in holes filled with water (no sea water) as well.

For wet concrete or drill holes filled with water curing time must be doubled.



Adhesives and Sealants

StickFX

Advantages



StickFX CL
Adhesive and sealant



StickFX XP
All-purpose
Adhesive and sealant

- MS Polymer - One-component adhesive and sealant with strong and quick initial adhesion
- Free of hazardous substances, odourless
- Contains no solvent, therefore especially suitable for fastening on tiles, Styrofoam, wood, and many plastics, etc.
- Can be painted over, even with water based paints
- Constant elasticity and vibration resistance once hardened
- Can be used on absorbent and non-absorbent base materials
- Surfaces can even be wet; underwater application also possible
- For indoor and outdoor use
- Colour fastness, weather resistant and UV resistant
- Temperature resistant -40°C to +90°C

Approvals and certificates



Applications

Multiple applications in the area of sanitary, heating and air conditioning, maintenance and repairs, doors and windows, construction in general, interior finishing, nautics aso.





StickFX Professional adhesive and sealant CL

Type	Art-No	Content [ml]	Colour	Description	€ / pc	[pcs]
CL	TR290MSCL	290	transparent	Adhesive and sealant		12



StickFX Professional all-purpose adhesive and sealant XP



Type	Art-No	Content [ml]	Colour	Description	€ / pc	[pcs]
XP grey	GR290MSXP	290	grey	All-purpose adhesive and sealant, fills gaps		12

Technical data at +20 °C and 65 % relative humidity

	StickFX Professional CL	StickFX Professional XP
Description	Crystal clear adhesive and sealant	All-purpose adhesive and sealant
Colour	100% transparent	grey
Base	MS Polymer	MS Polymer
Curing system	Moisture cure	Moisture cure
Initial tack	16 kg/m ²	40 kg/m ²
Final tack	24 kg/cm ²	18 kg/cm ²
Skin formation	ca. 10 minutes	ca. 10 minutes
Curing rate	2 - 3 mm / 24 hours	2 - 3 mm / 24 hours
Processing temperature	0 °C to +35 °C	0 °C to +35 °C
Temperature resistance	-40 °C to +90 °C	-40 °C to +90 °C
Specific gravity (DIN 53479)	1,04 g/ml	1,67 g/ml
Maximum deformation (DIN EN ISO 11600)	20 %	20 %
Elongation at break (DIN 53504)	300 %	750 %
Tear strength (DIN 53504)	2,4 N/mm ²	1,8 N/mm ²
Hardness (DIN 53505)	38 ± 5	40 ± 5
Storage	+5 °C to +25 °C	+5 °C to +25 °C
Shelf life*	15 months	15 months

* In unopened packaging

Further Installation Instructions/Guidelines

The surfaces need to be clean, dust free, and fat free

Outstanding adhesion on various surfaces such as metals, plastics/synthetic materials (polystyrene, polycarbonate, PVC, polyamide, and GFK – not ABS, PP, PE, PMMA, PTFE, and silicone), Styrofoam/polystyrene, cork, concrete, glass, wood, etc.

Chemical resistance: Good resistance against water (including seawater), aliphatic solvents, diluted inorganic acids and bases, oils, and fats/greases. Low resistance against aromatic solvents, concentrated acids and chlorinated hydrocarbons.



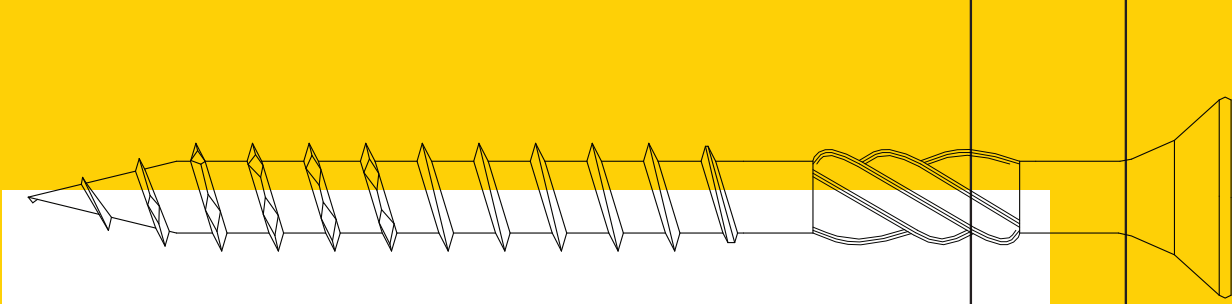

Joint dimensions:

Stick FX Professional CL: 1 - 3 mm for adhesion, 2 - 3 mm for sealing

Stick FX Professional XP: 2 - 10 mm for adhesion, 5 - 30 mm for sealing



Chipboard & construction screws

VELOX® SIT		206
VELOX® Pozi		210
VELOX® B		213
BMP		216
BMLP		217

Chipboard screws

VELOX® SIT



Advantages

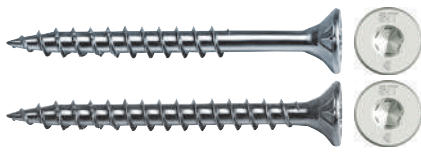

VELOX® SIT blue zinc plated, full and partial thread

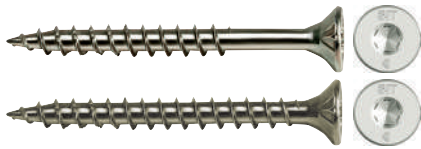

VELOX® SIT stainless steel A2, full and partial thread

- SIT recess (=AW recess from Würth)
 - Perfect power transfer
 - Long-lasting SIT bit
 - No damage to the screw head / zinc coating
 - Large improved working comfort; the conical recess centers the screw (no tumbling) and sticks on the bit
 - TX bits can also be used, but without the mentioned advantages
- Only one bit size for four screw diameters
- Underhead milling ribs and underhead milling pockets: perfect for wood and metal fittings because of flush fitting and fewer wood shavings on surface (for metal fittings: use screws with underhead milling pockets)
- Patented tip thread area
- Approved product for your safety

High performance from tip to head

Suitable building materials

Very suitable



• Wood



• Laminated/veneered wood

Suitable

• Nylon plugs

Approvals and certificates



European Technical Assessment
for use in timber constructions



Chipboard screws VELOX® SIT

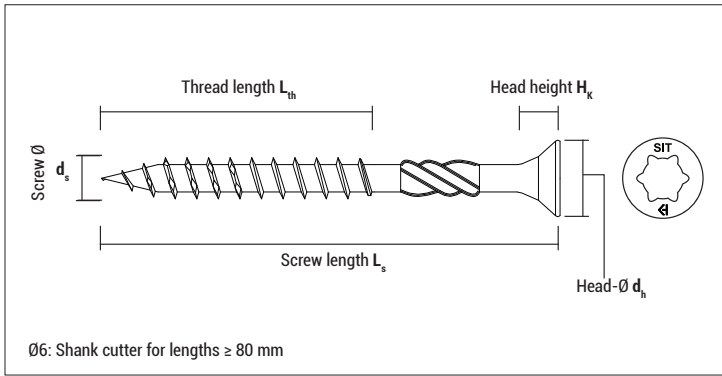

VELOX® SIT, blue zinc plated, partial thread

Type $d_s \times L_s / L_{th}$	Art-No	Thread length L_{th} [mm]	Head-Ø d_h [mm]	Head height H_k [mm]	SIT-Recess	ETA	€ / 100 pcs	[pcs]	[pcs]
3 x 35 / 20	9335VLOXSP	20	6	1,8	SIT/TX 10	●		1.000	5.000
3 x 40 / 25	9340VLOXSP	25	6	1,8	SIT/TX 10	●		500	6.000
3 x 45 / 25	9345VLOXSP	25	6	1,8	SIT/TX 10	●		500	4.000
External underhead milling ribs	3,5 x 40 / 25	93540VLOXSP	7	2,0	SIT/TX 20	●		500	4.000
	3,5 x 45 / 30	93545VLOXSP	7	2,0	SIT/TX 20	●		500	4.000
	3,5 x 50 / 30	93550VLOXSP	7	2,0	SIT/TX 20	●		500	3.000
Internal underhead milling pockets	4 x 35 / 20	9435VLOXSP	8	2,35	SIT/TX 20	●		500	4.000
	4 x 40 / 25	9440VLOXSP	8	2,35	SIT/TX 20	●		500	4.000
	4 x 45 / 30	9445VLOXSP	8	2,35	SIT/TX 20	●		500	3.000
	4 x 50 / 30	9450VLOXSP	8	2,35	SIT/TX 20	●		500	3.000
	4 x 60 / 35	9460VLOXSP	8	2,35	SIT/TX 20	●		250	2.000
	4 x 70 / 40	9470VLOXSP	8	2,35	SIT/TX 20	●		200	1.200
	4,5 x 40 / 25	94540VLOXSP	9	2,55	SIT/TX 20	●		500	3.000
	4,5 x 45 / 30	94545VLOXSP	9	2,55	SIT/TX 20	●		250	2.000
	4,5 x 50 / 30	94550VLOXSP	9	2,55	SIT/TX 20	●		250	2.000
	4,5 x 60 / 35	94560VLOXSP	9	2,55	SIT/TX 20	●		250	1.000
	4,5 x 70 / 40	94570VLOXSP	9	2,55	SIT/TX 20	●		200	1.200
	4,5 x 80 / 50	94580VLOXSP	9	2,55	SIT/TX 20	●		100	600
	5 x 40 / 25	9540VLOXSP	10	2,85	SIT/TX 20	●		500	3.000
	5 x 45 / 30	9545VLOXSP	10	2,85	SIT/TX 20	●		250	2.000
	5 x 50 / 30	9550VLOXSP	10	2,85	SIT/TX 20	●		250	1.500
5 x 60 / 35	9560VLOXSP	10	2,85	SIT/TX 20	●		250	1.500	
5 x 70 / 40	9570VLOXSP	10	2,85	SIT/TX 20	●		200	1.200	
5 x 80 / 50	9580VLOXSP	10	2,85	SIT/TX 20	●		100	600	
5 x 90 / 60	9590VLOXSP	10	2,85	SIT/TX 20	●		100	600	
5 x 100 / 60	95100VLOXSP	10	2,85	SIT/TX 20	●		50	600	
5 x 120 / 70	95120VLOXSP	10	2,85	SIT/TX 20	●		100	800	
External underhead milling ribs	6 x 50 / 30	9650VLOXSP	12	3,85	SIT/TX 30	●		250	1.500
	6 x 60 / 35	9660VLOXSP	12	3,85	SIT/TX 30	●		200	1.200
	6 x 70 / 40	9670VLOXSP	12	3,85	SIT/TX 30	●		100	800
	6 x 80 / 50	9680VLOXSP	12	3,85	SIT/TX 30	●		100	600
	6 x 90 / 60	9690VLOXSP	12	3,85	SIT/TX 30	●		50	400
	6 x 100 / 60	96100VLOXSP	12	3,85	SIT/TX 30	●		50	300
6 x 120 / 70	96120VLOXSP	12	3,85	SIT/TX 30	●		50	300	

Chipboard screws VELOX® SIT



VELOX® SIT, blue zinc plated, full thread

Type d _s x L _s / L _{th}	Art-No	Thread length L _{th} [mm]	Head-Ø d _h [mm]	Head height H _k [mm]	SIT- Recess	ETA	€ / 100 pcs	[pcs]	[pcs]
3 x 10	9310VLOXS	V	6	1,8	SIT/TX 10	–		1.000	24.000
3 x 12	9312VLOXS	V	6	1,8	SIT/TX 10	–		1.000	24.000
3 x 13 *	9313VLOXS	V	6	1,8	SIT/TX 10	–		1.000	32.000
3 x 15 *	9315VLOXS	V	6	1,8	SIT/TX 10	–		1.000	32.000
3 x 16	9316VLOXS	V	6	1,8	SIT/TX 10	–		1.000	12.000
3 x 20	9320VLOXS	V	6	1,8	SIT/TX 10	●		1.000	12.000
3 x 25	9325VLOXS	V	6	1,8	SIT/TX 10	●		1.000	12.000
3 x 30	9330VLOXS	V	6	1,8	SIT/TX 10	●		1.000	6.000
3 x 35	9335VLOXS	V	6	1,8	SIT/TX 10	●		1.000	5.000
3,5 x 12	93512VLOXS	V	7	2,0	SIT/TX 20	–		1.000	24.000
3,5 x 16	93516VLOXS	V	7	2,0	SIT/TX 20	–		1.000	12.000
3,5 x 20	93520VLOXS	V	7	2,0	SIT/TX 20	●		1.000	12.000
3,5 x 25	93525VLOXS	V	7	2,0	SIT/TX 20	●		1.000	12.000
3,5 x 30	93530VLOXS	V	7	2,0	SIT/TX 20	●		1.000	8.000
3,5 x 35	93535VLOXS	V	7	2,0	SIT/TX 20	●		500	6.000
3,5 x 40	93540VLOXS	V	7	2,0	SIT/TX 20	●		500	4.000
4 x 12	9412VLOXS	V	8	2,35	SIT/TX 20	–		1.000	12.000
4 x 16	9416VLOXS	V	8	2,35	SIT/TX 20	–		1.000	12.000
4 x 20	9420VLOXS	V	8	2,35	SIT/TX 20	–		1.000	12.000
4 x 25	9425VLOXS	V	8	2,35	SIT/TX 20	●		1.000	8.000
4 x 30	9430VLOXS	V	8	2,35	SIT/TX 20	●		500	6.000
4 x 35	9435VLOXS	V	8	2,35	SIT/TX 20	●		500	4.000
4 x 40	9440VLOXS	V	8	2,35	SIT/TX 20	●		500	4.000
4 x 45	9445VLOXS	V	8	2,35	SIT/TX 20	●		500	3.000
4 x 50	9450VLOXS	V	8	2,35	SIT/TX 20	●		500	3.000
4,5 x 20	94520VLOXS	V	9	2,55	SIT/TX 20	–		500	6.000
4,5 x 25	94525VLOXS	V	9	2,55	SIT/TX 20	–		500	6.000
4,5 x 30	94530VLOXS	V	9	2,55	SIT/TX 20	●		500	6.000
4,5 x 35	94535VLOXS	V	9	2,55	SIT/TX 20	●		500	4.000
4,5 x 40	94540VLOXS	V	9	2,55	SIT/TX 20	●		500	3.000
4,5 x 50	94550VLOXS	V	9	2,55	SIT/TX 20	●		250	2.000
5 x 20	9520VLOXS	V	10	2,85	SIT/TX 20	–		500	6.000
5 x 25	9525VLOXS	V	10	2,85	SIT/TX 20	–		500	6.000
5 x 30	9530VLOXS	V	10	2,85	SIT/TX 20	●		250	3.000
5 x 35	9535VLOXS	V	10	2,85	SIT/TX 20	●		250	3.000
5 x 40	9540VLOXS	V	10	2,85	SIT/TX 20	●		500	3.000
5 x 45	9545VLOXS	V	10	2,85	SIT/TX 20	●		250	2.000
5 x 50	9550VLOXS	V	10	2,85	SIT/TX 20	●		250	1.500
6 x 40 ¹⁾	9640VLOXS	V	12	3,85	SIT/TX 30	●		250	1.500

* discontinued article, delivery while stocks last

V = full thread

¹⁾ External underhead milling ribs

Chipboard screws VELOX® SIT



VELOX® SIT, stainless steel A2, partial thread

A2
STAINLESS
STEEL

Type $d_s \times L_s / L_{th}$	Art-No	Thread length L_{th} [mm]	Head-Ø d_h [mm]	Head height H_k [mm]	SIT- Recess	ETA	€ / 100 pcs	[pcs]	[pcs]
3,5 x 40 / 25	9X3540VLOXSP	25	7	2,0	SIT/TX 10	●		500	2.000
4 x 40 / 25	9X440VLOXSP	25	8	2,35	SIT/TX 20	●		500	2.000
4 x 50 / 30	9X450VLOXSP	30	8	2,35	SIT/TX 20	●		500	2.000
4 x 60 / 35	9X460VLOXSP	35	8	2,35	SIT/TX 20	●		250	1.000
External underhead milling ribs	4,5 x 40 / 25	9X4540VLOXSP	25	9	2,55	SIT/TX 20	●	500	2.000
	4,5 x 70 / 40	9X4570VLOXSP	40	9	2,55	SIT/TX 20	●	200	800
	5 x 50 / 30	9X550VLOXSP	30	10	2,85	SIT/TX 25	●	250	1.000
	5 x 60 / 35	9X560VLOXSP	35	10	2,85	SIT/TX 25	●	250	1.000
	5 x 90 / 60	9X590VLOXSP	60	10	2,85	SIT/TX 25	●	100	400
	6 x 50 / 30	9X650VLOXSP	30	12	3,85	SIT/TX 30	●	250	1.000
	6 x 60 / 35	9X660VLOXSP	35	12	3,85	SIT/TX 30	●	200	800
	6 x 70 / 40	9X670VLOXSP	40	12	3,85	SIT/TX 30	●	100	400
	6 x 80 / 50	9X680VLOXSP	50	12	3,85	SIT/TX 30	●	100	400
	6 x 90 / 60	9X690VLOXSP	60	12	3,85	SIT/TX 30	●	50	200
6 x 100 / 60	9X6100VLOXSP	60	12	3,85	SIT/TX 30	●	50	200	
6 x 120 / 70	9X6120VLOXSP	70	12	3,85	SIT/TX 30	●	100	1.400	



VELOX® SIT, stainless steel A2, full thread

A2
STAINLESS
STEEL

Type $d_s \times L_s / L_{th}$	Art-No	Thread length L_{th} [mm]	Head-Ø d_h [mm]	Head height H_k [mm]	SIT- Recess	ETA	€ / 100 pcs	[pcs]	[pcs]
3 x 20	9X320VLOXS	V	6	1,8	SIT/TX 10	●		1.000	4.000
3 x 30	9X330VLOXS	V	6	1,8	SIT/TX 10	●		1.000	4.000
3,5 x 15	9X3515VLOXS	V	7	2,0	SIT/TX 10	–		1.000	4.000
3,5 x 20	9X3520VLOXS	V	7	2,0	SIT/TX 10	●		1.000	4.000
3,5 x 25	9X3525VLOXS	V	7	2,0	SIT/TX 10	●		1.000	4.000
3,5 x 30	9X3530VLOXS	V	7	2,0	SIT/TX 10	●		1.000	4.000
4 x 20 *	9X420VLOXS	V	8	2,35	SIT/TX 20	–		1.000	4.000
4 x 25 *	9X425VLOXS	V	8	2,35	SIT/TX 20	●		500	2.000
4 x 30	9X430VLOXS	V	8	2,35	SIT/TX 20	●		500	2.000
External underhead milling ribs	4 x 35	9X435VLOXS	V	8	2,35	SIT/TX 20	●	500	2.000
	4,5 x 30	9X4530VLOXS	V	9	2,55	SIT/TX 20	●	500	2.000
	4,5 x 40	9X4540VLOXS	V	9	2,55	SIT/TX 20	●	500	4.000

* discontinued article, delivery while stocks last

V = full thread

Chipboard screws

VELOX® Pozi



Advantages

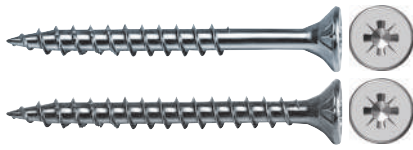

VELOX® Pozi blue zinc plated, full and partial thread

- Underhead milling ribs and underhead milling pockets: perfect for wood and metal fittings because of flush fitting and fewer wood shavings on surface (for metal fittings: use screws with underhead milling pockets)
- Patented tip thread area reduces splitting as well as setting torque, which provides a perfect appearance and a longer battery life
- Approved product for your safety

Suitable building materials

Very suitable



- Wood



- Laminated/veneered wood

Suitable

- Nylon plugs

Approvals and certificates



Chipboard screws VELOX® Pozi

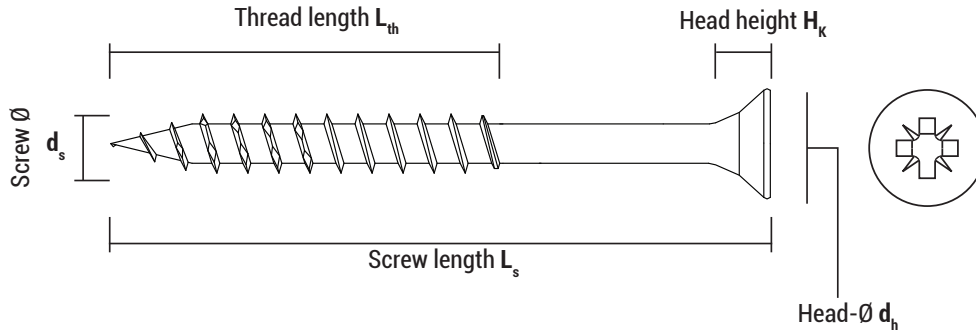

VELOX® Pozi, blue zinc plated, partial thread



Type $d_s \times L_s / L_{th}$	Art-No	Thread length L_{th} [mm]	Head-Ø d_h [mm]	Head height H_k [mm]	PZ- Recess	ETA	€ / 100 pcs	[pcs]	[pcs]
3 x 35 / 20	9335VLOXP	20	6	1,8	PZ 1	●		1.000	5.000
3 x 40/25	9340VLOXP	25	6	1,8	PZ 1	●		500	6.000
3 x 45/25	9345VLOXP	25	6	1,8	PZ 1	●		500	4.000
Internal underhead milling pockets	3,5x35/20 *	93535VLOXP	20	7	2,0	PZ 2	●	500	6.000
	3,5x40/25	93540VLOXP	25	7	2,0	PZ 2	●	500	4.000
	3,5x45/30	93545VLOXP	30	7	2,0	PZ 2	●	500	4.000
	3,5x50/30	93550VLOXP	30	7	2,0	PZ 2	●	500	3.000
	4 x 35/20	9435VLOXP	20	8	2,35	PZ 2	●	500	4.000
	4 x 40/25	9440VLOXP	25	8	2,35	PZ 2	●	500	4.000
	4 x 45/30	9445VLOXP	30	8	2,35	PZ 2	●	500	3.000
	4 x 50/30	9450VLOXP	30	8	2,35	PZ 2	●	500	3.000
	4 x 60/35	9460VLOXP	35	8	2,35	PZ 2	●	250	2.000
	4 x 70/40	9470VLOXP	40	8	2,35	PZ 2	●	200	1.200
	4,5x40/25	94540VLOXP	25	9	2,55	PZ 2	●	500	3.000
	4,5x45/30	94545VLOXP	30	9	2,55	PZ 2	●	250	2.000
	4,5x50/30	94550VLOXP	30	9	2,55	PZ 2	●	250	2.000
	4,5x60/35	94560VLOXP	35	9	2,55	PZ 2	●	250	1.000
	4,5x70/40	94570VLOXP	40	9	2,55	PZ 2	●	200	1.200
	4,5x80/50	94580VLOXP	50	9	2,55	PZ 2	●	100	600
	5 x 40/25	9540VLOXP	25	10	2,85	PZ 2	●	500	3.000
	5 x 45/30	9545VLOXP	30	10	2,85	PZ 2	●	250	2.000
	5 x 50/30	9550VLOXP	30	10	2,85	PZ 2	●	250	1.500
	5 x 60/35	9560VLOXP	35	10	2,85	PZ 2	●	250	1.500
5 x 70/40	9570VLOXP	40	10	2,85	PZ 2	●	200	1.200	
5 x 80/50	9580VLOXP	50	10	2,85	PZ 2	●	100	600	
5 x 90/60	9590VLOXP	60	10	2,85	PZ 2	●	100	600	
5 x 100/60	95100VLOXP	60	10	2,85	PZ 2	●	50	600	
External underhead milling ribs	6 x 50/30	9650VLOXP	30	12	3,85	PZ 3	●	250	1.500
	6 x 60/35	9660VLOXP	35	12	3,85	PZ 3	●	200	1.200
	6 x 70/40	9670VLOXP	40	12	3,85	PZ 3	●	100	800
	6 x 80/50	9680VLOXP	50	12	3,85	PZ 3	●	100	600

* discontinued article, delivery while stocks last

Chipboard screws VELOX® Pozi



VELOX® Pozi, blue zinc plated, full thread

Type $d_s \times L_s / L_{th}$	Art-No	Thread length L_{th} [mm]	Head-Ø d_h [mm]	Head height H_k [mm]	PZ- Recess		€ / 100 pcs	 [pcs]	 [pcs]
3 x 10	9310VLOX	V	6	1,8	PZ 1	–		1.000	24.000
3 x 12	9312VLOX	V	6	1,8	PZ 1	–		1.000	24.000
3 x 13 *	9313VLOX	V	6	1,8	PZ 1	–		1.000	32.000
3 x 16	9316VLOX	V	6	1,8	PZ 1	–		1.000	12.000
3 x 20	9320VLOX	V	6	1,8	PZ 1	●		1.000	12.000
3 x 25	9325VLOX	V	6	1,8	PZ 1	●		1.000	12.000
3 x 30	9330VLOX	V	6	1,8	PZ 1	●		1.000	6.000
3 x 35	9335VLOX	V	6	1,8	PZ 1	●		1.000	5.000
3,5 x 12	93512VLOX	V	7	2,0	PZ 2	–		1.000	24.000
3,5 x 16	93516VLOX	V	7	2,0	PZ 2	–		1.000	12.000
3,5 x 17 *	93517VLOX	V	7	2,0	PZ 2	–		1.000	12.000
3,5 x 20	93520VLOX	V	7	2,0	PZ 2	●		1.000	12.000
3,5 x 25	93525VLOX	V	7	2,0	PZ 2	●		1.000	12.000
3,5 x 30	93530VLOX	V	7	2,0	PZ 2	●		1.000	8.000
3,5 x 35	93535VLOX	V	7	2,0	PZ 2	●		500	6.000
3,5 x 40	93540VLOX	V	7	2,0	PZ 2	●		500	4.000
4 x 12	9412VLOX	V	8	2,35	PZ 2	–		1.000	12.000
4 x 16	9416VLOX	V	8	2,35	PZ 2	–		1.000	12.000
4 x 20	9420VLOX	V	8	2,35	PZ 2	–		1.000	12.000
4 x 25	9425VLOX	V	8	2,35	PZ 2	●		1.000	8.000
4 x 30	9430VLOX	V	8	2,35	PZ 2	●		500	6.000
4 x 35	9435VLOX	V	8	2,35	PZ 2	●		500	4.000
4 x 40	9440VLOX	V	8	2,35	PZ 2	●		500	4.000
4 x 45	9445VLOX	V	8	2,35	PZ 2	●		500	3.000
4 x 50	9450VLOX	V	8	2,35	PZ 2	●		500	3.000
4,5 x 20	94520VLOX	V	9	2,55	PZ 2	–		500	6.000
4,5 x 25	94525VLOX	V	9	2,55	PZ 2	–		500	6.000
4,5 x 30	94530VLOX	V	9	2,55	PZ 2	●		500	6.000
4,5 x 35	94535VLOX	V	9	2,55	PZ 2	●		500	4.000
4,5 x 40	94540VLOX	V	9	2,55	PZ 2	●		500	3.000
4,5 x 50	94550VLOX	V	9	2,55	PZ 2	●		250	2.000
5 x 20	9520VLOX	V	10	2,85	PZ 2	–		500	6.000
5 x 25	9525VLOX	V	10	2,85	PZ 2	–		500	6.000
5 x 30	9530VLOX	V	10	2,85	PZ 2	●		250	3.000
5 x 35	9535VLOX	V	10	2,85	PZ 2	●		250	3.000
5 x 40	9540VLOX	V	10	2,85	PZ 2	●		500	3.000
5 x 45	9545VLOX	V	10	2,85	PZ 2	●		250	2.000
5 x 50	9550VLOX	V	10	2,85	PZ 2	●		250	1.500
6 x 40	9640VLOX	V	12	3,85	PZ3	●		250	1.500

* discontinued article, delivery while stocks last

V = full thread

Chipboard screws VELOX® B



Advantages



- Patented tip thread area reduces splitting as well as setting torque, which provides a perfect appearance and a longer battery life
- Approved product for your safety
- Pan-head

Suitable building materials

Very suitable



- Wood



Suitable

- Nylon plugs

Approvals and certificates



Chipboard screws VELOX® B

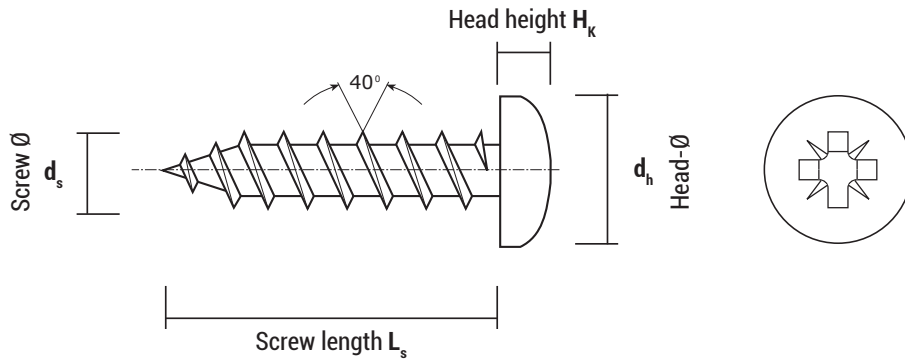

VELOX® B, blue zinc plated

Type $d_s \times L_s$	Art-No	Thread length L_{th} [mm]	Head-Ø d_h [mm]	Head height H_k [mm]	PZ- Recess		€ / 100 pcs	 [pcs]	 [pcs]
3 x 15	9315VLOXB	V	6	2,25	PZ 1	●		1.000	4.000
3 x 20	9320VLOXB	V	6	2,25	PZ 1	●		1.000	4.000
3,5 x 20	93520VLOXB	V	7	2,5	PZ 2	●		1.000	4.000
3,5 x 25	93525VLOXB	V	7	2,5	PZ 2	●		1.000	4.000
3,5 x 30	93530VLOXB	V	7	2,5	PZ 2	●		1.000	4.000
3,5 x 35	93535VLOXB	V	7	2,5	PZ 2	●		500	2.000
3,5 x 40	93540VLOXB	V	7	2,5	PZ 2	●		500	2.000
4 x 15	9415VLOXB	V	8	2,8	PZ 2	-		1.000	4.000
4 x 20	9420VLOXB	V	8	2,8	PZ 2	●		1.000	4.000
4 x 30	9430VLOXB	V	8	2,8	PZ 2	●		500	2.000
4 x 35	9435VLOXB	V	8	2,8	PZ 2	●		500	2.000
4 x 40	9440VLOXB	V	8	2,8	PZ 2	●		500	2.000
4 x 50	9450VLOXB	V	8	2,8	PZ 2	●		250	1.000
4 x 60	9460VLOXB	V	8	2,8	PZ 2	●		250	1.000
4,5 x 30	94530VLOXB	V	9	3,1	PZ 2	●		500	2.000
4,5 x 35	94535VLOXB	V	9	3,1	PZ 2	●		500	2.000
4,5 x 40	94540VLOXB	V	9	3,1	PZ 2	●		500	2.000
4,5 x 45	94545VLOXB	V	9	3,1	PZ 2	●		250	1.000
4,5 x 50	94550VLOXB	V	9	3,1	PZ 2	●		250	1.000
5 x 25	9525VLOXB	V	10	3,5	PZ 2	●		500	2.000
5 x 30	9530VLOXB	V	10	3,5	PZ 2	●		250	1.000
5 x 35	9535VLOXB	V	10	3,5	PZ 2	●		250	1.000
5 x 40	9540VLOXB	V	10	3,5	PZ 2	●		250	1.000

V = full thread

Construction screw BMax



Advantages



BMax countersunk head, zinc plated



BMax wafer head screw, zinc plated

- ETA approval for highest requirements and constant quality
- Flush finishing in wood due to external underhead milling ribs
- Special notch tip for quick bite without splitting
- Shank cutter reduces the setting torque and increases the battery life (especially for long screws)
- Wafer head screw for a better contact pressure (bigger contact area on boards)
- See screw design software at: www.celofixings.com

Approvals and certificates



Suitable building materials

Very suitable



- Wood



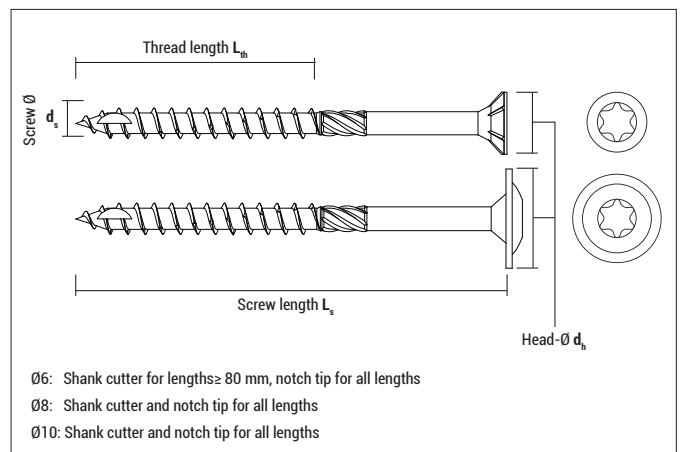

Mounting



Construction screw BMax





BMax countersunk head, zinc plated

Type	Art-No	Screws- Ø d _s [mm]	Screw length L _s [mm]	Thread length L _{th} [mm]	Head-Ø d _h [mm]	Recess		€ / 100 pcs	 [pcs]	 [pcs]
6 x 40	9640BMP	6	40	32	12,0	TX 30	●		200	3.200
6 x 50	9650BMP	6	50	42	12,0	TX 30	●		200	3.200
6 x 60	9660BMP	6	60	52	12,0	TX 30	●		200	2.400
6 x 70	9670BMP	6	70	52	12,0	TX 30	●		100	1.600
6 x 80	9680BMP	6	80	52	12,0	TX 30	●		100	1.600
6 x 100	96100BMP	6	100	52	12,0	TX 30	●		100	1.200
6 x 120	96120BMP	6	120	52	12,0	TX 30	●		100	1.200
6 x 140	96140BMP	6	140	75	12,0	TX 30	●		100	800
6 x 160	96160BMP	6	160	75	12,0	TX 30	●		100	800
6 x 180	96180BMP	6	180	75	12,0	TX 30	●		100	800
6 x 200	96200BMP	6	200	75	12,0	TX 30	●		100	800
6 x 220	96220BMP	6	220	75	12,0	TX 30	●		100	800
6 x 240	96240BMP	6	240	75	12,0	TX 30	●		100	600
6 x 260	96260BMP	6	260	75	12,0	TX 30	●		100	600
6 x 280	96280BMP	6	280	75	12,0	TX 30	●		100	600
6 x 300	96300BMP	6	300	75	12,0	TX 30	●		100	600
8 x 80	9880BMP	8	80	52	15,0	TX 40	●		50	800
8 x 100	98100BMP	8	100	52	15,0	TX 40	●		50	800
8 x 120	98120BMP	8	120	52	15,0	TX 40	●		50	600
8 x 140	98140BMP	8	140	80	15,0	TX 40	●		50	600
8 x 160	98160BMP	8	160	80	15,0	TX 40	●		50	400
8 x 180	98180BMP	8	180	80	15,0	TX 40	●		50	400
8 x 200	98200BMP	8	200	80	15,0	TX 40	●		50	400
8 x 220	98220BMP	8	220	100	15,0	TX 40	●		50	400
8 x 240	98240BMP	8	240	100	15,0	TX 40	●		50	300
8 x 260	98260BMP	8	260	100	15,0	TX 40	●		50	300
8 x 280	98280BMP	8	280	100	15,0	TX 40	●		50	300
8 x 300	98300BMP	8	300	100	15,0	TX 40	●		50	300
8 x 320	98320BMP	8	320	100	15,0	TX 40	●		50	300
8 x 340	98340BMP	8	340	100	15,0	TX 40	●		50	300
8 x 360	98360BMP	8	360	100	15,0	TX 40	●		50	200
8 x 380	98380BMP	8	380	100	15,0	TX 40	●		50	200
8 x 400	98400BMP	8	400	100	15,0	TX 40	●		50	200
10 x 80	91080BMP	10	80	52	18,5	TX 50	●		50	800
10 x 100	910100BMP	10	100	52	18,5	TX 50	●		50	800
10 x 120	910120BMP	10	120	52	18,5	TX 50	●		50	600
10 x 140	910140BMP	10	140	80	18,5	TX 50	●		50	600
10 x 160	910160BMP	10	160	80	18,5	TX 50	●		50	400
10 x 180	910180BMP	10	180	80	18,5	TX 50	●		50	400
10 x 200	910200BMP	10	200	80	18,5	TX 50	●		50	400
10 x 220	910220BMP	10	220	100	18,5	TX 50	●		50	400
10 x 240	910240BMP	10	240	100	18,5	TX 50	●		50	300
10 x 260	910260BMP	10	260	100	18,5	TX 50	●		50	300
10 x 280	910280BMP	10	280	100	18,5	TX 50	●		50	300
10 x 300	910300BMP	10	300	100	18,5	TX 50	●		50	300
10 x 320	910320BMP	10	320	100	18,5	TX 50	●		50	300
10 x 340	910340BMP	10	340	100	18,5	TX 50	●		50	300
10 x 360	910360BMP	10	360	100	18,5	TX 50	●		50	200
10 x 380	910380BMP	10	380	100	18,5	TX 50	●		50	200
10 x 400	910400BMP	10	400	100	18,5	TX 50	●		50	200

Construction screw BMax







BMax wafer head, zinc plated

Type	Art-No	Screws- Ø d _s [mm]	Screw length L _s [mm]	Thread length L _{th} [mm]	Head-Ø d _h [mm]	Recess		€ / 100 pcs	 [pcs]	 [pcs]
6 x 40	9640BMLP	6	40	32	15,0	TX 30	●		200	2.400
6 x 50	9650BMLP	6	50	42	15,0	TX 30	●		200	2.400
6 x 60	9660BMLP	6	60	52	15,0	TX 30	●		200	2.400
6 x 70	9670BMLP	6	70	52	15,0	TX 30	●		100	1.600
6 x 80	9680BMLP	6	80	52	15,0	TX 30	●		100	1.600
6 x 100	96100BMLP	6	100	52	15,0	TX 30	●		100	1.200
6 x 120	96120BMLP	6	120	52	15,0	TX 30	●		100	1.200
6 x 140	96140BMLP	6	140	75	15,0	TX 30	●		100	800
6 x 160	96160BMLP	6	160	75	15,0	TX 30	●		100	800
6 x 180	96180BMLP	6	180	75	15,0	TX 30	●		100	800
6 x 200	96200BMLP	6	200	75	15,0	TX 30	●		100	800
6 x 220	96220BMLP	6	220	75	15,0	TX 30	●		100	800
6 x 240	96240BMLP	6	240	75	15,0	TX 30	●		100	600
6 x 260	96260BMLP	6	260	75	15,0	TX 30	●		100	600
6 x 280	96280BMLP	6	280	75	15,0	TX 30	●		100	600
6 x 300	96300BMLP	6	300	75	15,0	TX 30	●		100	600
8 x 80	9880BMLP	8	80	52	22,0	TX 40	●		50	800
8 x 100	98100BMLP	8	100	52	22,0	TX 40	●		50	600
8 x 120	98120BMLP	8	120	52	22,0	TX 40	●		50	600
8 x 140	98140BMLP	8	140	80	22,0	TX 40	●		50	400
8 x 160	98160BMLP	8	160	80	22,0	TX 40	●		50	400
8 x 180	98180BMLP	8	180	80	22,0	TX 40	●		50	400
8 x 200	98200BMLP	8	200	80	22,0	TX 40	●		50	400
8 x 220	98220BMLP	8	220	100	22,0	TX 40	●		50	400
8 x 240	98240BMLP	8	240	100	22,0	TX 40	●		50	300
8 x 260	98260BMLP	8	260	100	22,0	TX 40	●		50	300
8 x 280	98280BMLP	8	280	100	22,0	TX 40	●		50	300
8 x 300	98300BMLP	8	300	100	22,0	TX 40	●		50	300
8 x 320	98320BMLP	8	320	100	22,0	TX 40	●		50	300
8 x 340	98340BMLP	8	340	100	22,0	TX 40	●		50	200
8 x 360	98360BMLP	8	360	100	22,0	TX 40	●		50	200
8 x 380	98380BMLP	8	380	100	22,0	TX 40	●		50	200
8 x 400	98400BMLP	8	400	100	22,0	TX 40	●		50	200
10 x 80	91080BMLP	10	80	52	25,0	TX 50	●		50	600
10 x 100	910100BMLP	10	100	52	25,0	TX 50	●		50	400
10 x 120	910120BMLP	10	120	52	25,0	TX 50	●		50	400
10 x 140	910140BMLP	10	140	80	25,0	TX 50	●		50	400
10 x 160	910160BMLP	10	160	80	25,0	TX 50	●		50	400
10 x 180	910180BMLP	10	180	80	25,0	TX 50	●		50	300
10 x 200	910200BMLP	10	200	80	25,0	TX 50	●		50	300
10 x 220	910220BMLP	10	220	100	25,0	TX 50	●		50	300
10 x 240	910240BMLP	10	240	100	25,0	TX 50	●		50	300
10 x 260	910260BMLP	10	260	100	25,0	TX 50	●		50	300
10 x 280	910280BMLP	10	280	100	25,0	TX 50	●		50	300
10 x 300	910300BMLP	10	300	100	25,0	TX 50	●		50	200
10 x 320	910320BMLP	10	320	100	25,0	TX 50	●		50	200
10 x 340	910340BMLP	10	340	100	25,0	TX 50	●		50	–
10 x 360	910360BMLP	10	360	100	25,0	TX 50	●		50	–
10 x 380	910380BMLP	10	380	100	25,0	TX 50	●		50	–
10 x 400	910400BMLP	10	400	100	25,0	TX 50	●		50	–



Other Screws

DIN 571		219
JS		221
OES		222
EDR		223
Torab® P		224

Wood screw DIN 571

Advantages



- Classic wood screw, manufactured in accordance with DIN 571
- Especially well-suited for nylon plugs



Suitable building materials

Very suitable



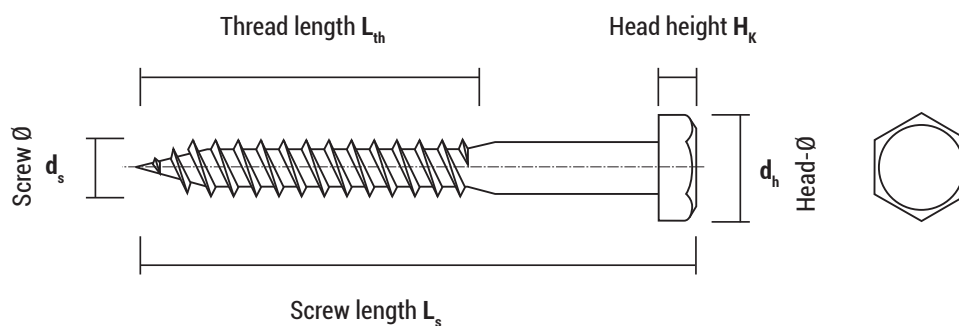

- Wood
- Nylon plugs





DIN 571, zinc plated

Type $d_s \times L_s$	Art-No	Min. Thread length L_{th} [mm]	Head height L_{th} [mm]	Head-Ø $d_h = \text{Recess}$ [mm]	€ / 100 pcs	 [pcs]	 [pcs]
6 x 30	9630571	18	4,00	SW10		250	3.000
6 x 40	9640571	24	4,00	SW10		250	2.000
6 x 50	9650571	30	4,00	SW10		250	2.000
6 x 60	9660571	36	4,00	SW10		100	800
6 x 70	9670571	42	4,00	SW10		100	800
6 x 80	9680571	48	4,00	SW10		100	800
6 x 100	96100571	60	4,00	SW10		200	800
8 x 40	9840571	24	5,85	SW13		200	1.600
8 x 50	9850571	30	5,85	SW13		250	1.000
8 x 60	9860571	36	5,85	SW13		250	1.000
8 x 70	9870571	42	5,85	SW13		200	800
8 x 80	9880571	48	5,85	SW13		100	400
8 x 90	9890571	54	5,85	SW13		100	400
8 x 100	98100571	60	5,85	SW13		100	400
8 x 120	98120571	72	5,85	SW13		100	400
8 x 140	98140571	84	5,85	SW13		100	400
8 x 150	98150571	90	5,85	SW13		100	400
10 x 50	91050571	30	7,00	SW17		200	800
10 x 60	91060571	36	7,00	SW17		100	400
10 x 70	91070571	42	7,00	SW17		100	400
10 x 80	91080571	48	7,00	SW17		100	400
10 x 90	91090571	54	7,00	SW17		100	400
10 x 100	910100571	60	7,00	SW17		100	400
10 x 120	910120571	72	7,00	SW17		50	200
10 x 140	910140571	84	7,00	SW17		50	200
10 x 160	910160571	102	7,00	SW17		50	200
10 x 180	910180571	110	7,00	SW17		50	200

Adjustment screw

JS

Advantages



- Suitable for the adjustment wooden batten substructures
- Easy and variable alignment of battens to the desired spacing
- Can also be used in combination with plugs (for example F, FX, MZK, etc.)
- Underhead milling ribs for flush finishing in wood

Suitable building materials

Very suitable



- Wood

- Nylon plugs



Mounting

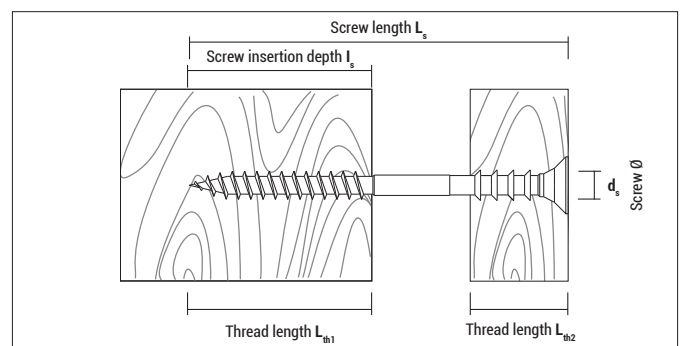
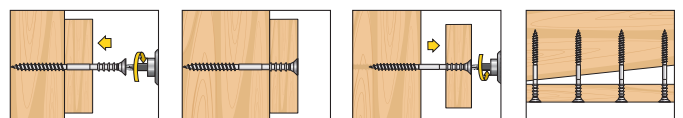

JS, blue zinc plated, TX25

Type $d_s \times L_s$	Art-No	d_s [mm]	L_s [mm]	l_s [mm]	L_{th1} [mm]	L_{th2} [mm]	€/ 100 pcs	[pcs]	[pcs]
6x60	9660JS	6	60	40	30	20		100	600
6x70	9670JS	6	70	40	40	25		100	600
6x80	9680JS	6	80	40	50	25		100	600
6x100	96100JS	6	100	40	60	25		100	600
6x120	96120JS	6	120	40	80	25		100	600
6x145	96145JS	6	145	40	80	25		100	600

Eyebolt screw OES



Advantages



- The scaffold plug GR (see page 39) matches optimally with the eyebolt screw OES for high load values
- Markings on the eyebolt screw facilitate controlled screwing-in
- The eyebolt can also be screwed directly into wood

Suitable building materials

Very suitable



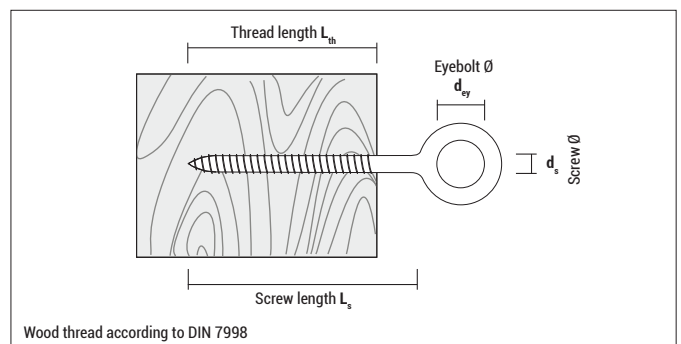

- Wood
- Scaffold plug GR (see page 39)

Mounting



OES, zinc plated

Type	Art-No	d _s [mm]	L _s [mm]	d _{ey} [mm]	€ / 100 pcs	 [pcs]	 [pcs]
OES 12x90	912900ES	12	90	23		20	60
OES 12x120	9121200ES	12	120	23		20	60
OES 12x160	9121600ES	12	160	23		20	60
OES 12x190	9121900ES	12	190	23		20	60
OES 12x230	9122300ES	12	230	23		20	60
OES 12x300	9123000ES	12	300	23		20	60
OES 12x350	9123500ES	12	350	23		20	60

Hanger bolt

EDR

Advantages



- Hanger bolts have a wooden thread on one side and a metric thread on the other
- Suitable for fixing directly into wood or in combination with plugs into other base materials
- For easy installation with external hex and TX recess



Suitable building materials

Very suitable





- Wood

- Nylon plugs

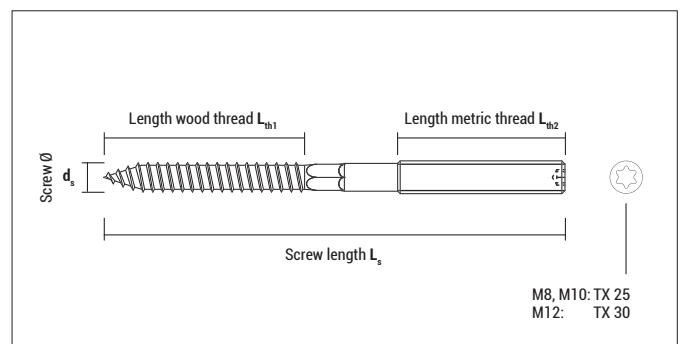
Mounting



EDR, zinc plated

Type $d_s \times L_s$	Art-No	d_s [mm]	L_s [mm]	L_{th1} [mm]	L_{th2} [mm]	€ / 100 pcs	 [pcs]	 [pcs]
M8 x 50	9850EDR	8	50	30	15		100	1.800
M8 x 60	9860EDR	8	60	30	20		100	1.800
M8 x 80	9880EDR	8	80	40	30		50	900
M8 x 100	98100EDR	8	100	45	40		50	900
M8 x 120	98120EDR	8	120	50	50		50	900
M10 x 80	91080EDR	10	80	40	30		50	600
M10 x 100	910100EDR	10	100	60	30		50	600
M10 x 120	910120EDR	10	120	60	40		50	600
M10 x 140	910140EDR	10	140	60	50		50	600
M12 x 125	912125EDR40	12	125	60	40		40	240

Wood screw with internal thread Torab® P



Advantages



- Wood screw with internal thread M6 or M8 for e.g. threaded rods; nor further adaptors necessary
- Almost 50% less installation time necessary compared to alternative methods
- Double thread for quick screwing in
- Perfect solution when combined with e.g. multi-purpose plug MZK, especially for perforated bricks, boards, etc.

Suitable building materials

Very suitable



• Wood

• Nylon plugs



Torab® P, zinc plated

Type	Art-No	Wood thread	Connecting thread	Recess	Suitable for plug-Ø [mm]	€ / 100 pcs	[pcs]	[pcs]
Torab P M6	9635TRBP	4,5x35	M 6	SW 10	6		100	1.800
Torab P M8	9845TRBP	5,5x45	M 8	SW 10	8		50	900

Mounting

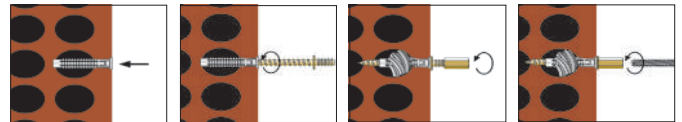

Alternative method: 15 seconds

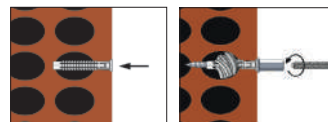

Torab® P : 8 seconds



Socket wrench for installing Torab® P



Type	Art-No	€ / 1 pcs	[pcs]	[pcs]
Socket wrench 10	910LLTRBCA		1	-

Recommended loads in wood (C24) fully screwed in no pre-drilling required

Type	Min. screw-in depth [mm]	Pull-out resistance F_{rec} [kN]	max. bending moment M_{rec} [kN]	max. shear force V_{rec} [kN]
Torab P M6	30	0,39	0,54	0,61
Torab P M8	40	0,66	1,08	0,96

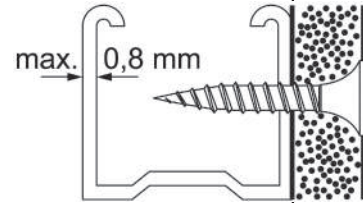
Drywall Screws



SSF		227
SSG		227
SSB		227
GSH		228
GGs		228
PVS		228

Drywall screws



Advantages



Fine thread screw SSF



Coarse thread screw SSG



Drill point screw SSB



Fibreboard screw GSH



Drywall-to-drywall screw GGS



Metal framing screw PVS

- Trumpet head screws for finishing flush with the building material and easy covering / plastering
- Black phosphating for corrosion protection and against a chemical reaction with the plasterboard
- Constantly high quality

Suitable building materials

Very suitable



- Wooden framework
- C&W-Profiles up to 0,8 mm
- Reinforcing profiles up to 2,25 mm
- Plasterboard/ Fibreboard
- Gypsum fibreboards



Drywall screws

Fine thread screw SSF

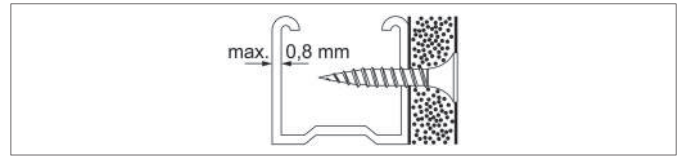
for metal framework



SSF PH 2



Type	Art-No	€ / 100 pcs	 [pcs]	 [pcs]
3,5 x 25	9F3525SSF		1.000	16.000
3,5 x 35	9F3535SSF		1.000	12.000
3,5 x 45	9F3545SSF		500	6.000
3,5 x 55	9F3555SSF		500	6.000
3,9 x 25	9F3925SSF		1.000	16.000
3,9 x 35	9F3935SSF		1.000	12.000
3,9 x 45	9F3945SSF		500	6.000
3,9 x 55	9F3955SSF		500	6.000
3,9 x 65	9F3965SSF		500	4.000
4,2 x 75	9F4275SSF		200	3.200
5,0 x 90	9F590SSF		200	2.400

Coarse thread screw SSG

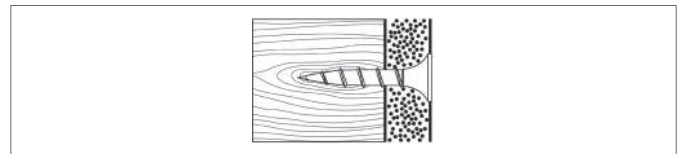
for wooden framework



SSG PH 2



Type	Art-No	€ / 100 pcs	 [pcs]	 [pcs]
3,9 x 25	9F3925SSG		1.000	16.000
3,9 x 35	9F3935SSG		1.000	12.000
3,9 x 45	9F3945SSG		500	6.000
3,9 x 55	9F3955SSG		500	6.000
4,2 x 75	9F4275SSG		200	3.200
5,0 x 90	9F590SSG		200	1.600

Drill point screw SSB

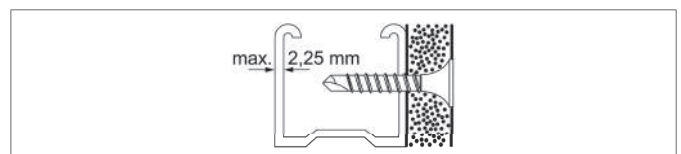
for metal reinforcing framework up to 2,25 mm



SSB PH 2

Type	Art-No	€ / 100 pcs	 [pcs]	 [pcs]
3,5 x 25	9F3525SSB		1.000	16.000
3,5 x 35	9F3535SSB		1.000	12.000
3,5 x 45	9F3545SSB		500	6.000
3,5 x 55	9F3555SSB		500	6.000

Drywall screws

Fibreboard screw GSH

Special drywall screw for gypsum fibreboards



GSH PH 2

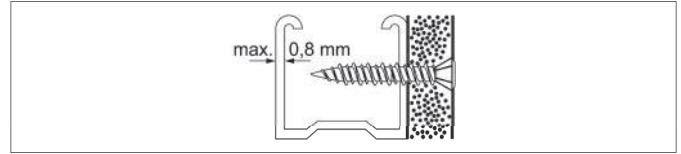

Type	Art-No	€ / 100 pcs	[pcs]	[pcs]
3,9x19	9F3919GSH		1.000	16.000
3,9x22	9F3922GSH		1.000	16.000
3,9x30	9F3930GSH		1.000	12.000
3,9x35	9F3935GSH		500	6.000
3,9x45	9F3945GSH		500	6.000
3,9x55	9F3955GSH		500	6.000
3,9x65	9F3965GSH		500	4.000

Drywall-to-drywall screw GGS

For connecting plasterboards



GGS PH 2

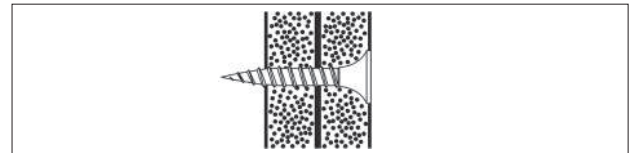

Type	Art-No	€ / 100 pcs	[pcs]	[pcs]
5,0x38	9F538GGS		500	6.000

Metal framing screw PVS

Special drywall screw for connecting metal frame profiles



PVS blue zinc plated, PH 2, head-Ø 11 mm

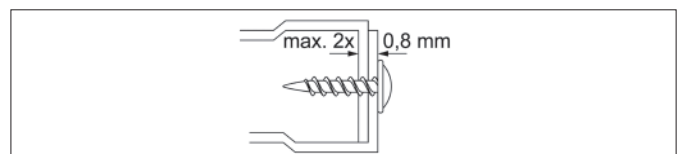

Type	Art-No	€ / 100 pcs	[pcs]	[pcs]
4,2x13	94213PVS		1.000	24.000

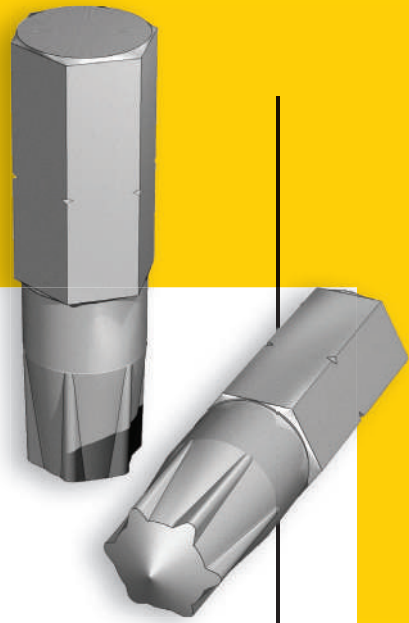

Screws Accessories

Magic Tap  230

SIT®-Bits  232

PH-Bits  233

PZ-Bits  233

TX-Bits  233

Duo-Bits  233

Self-adhesive PVC cover Magic Tap

Advantages



- Nearly invisible
- Extreme adhesive strength on wood veneer and smooth surfaces
- Permanently durable material, water resistant
- Matches all countersunk screws
- 14 colours

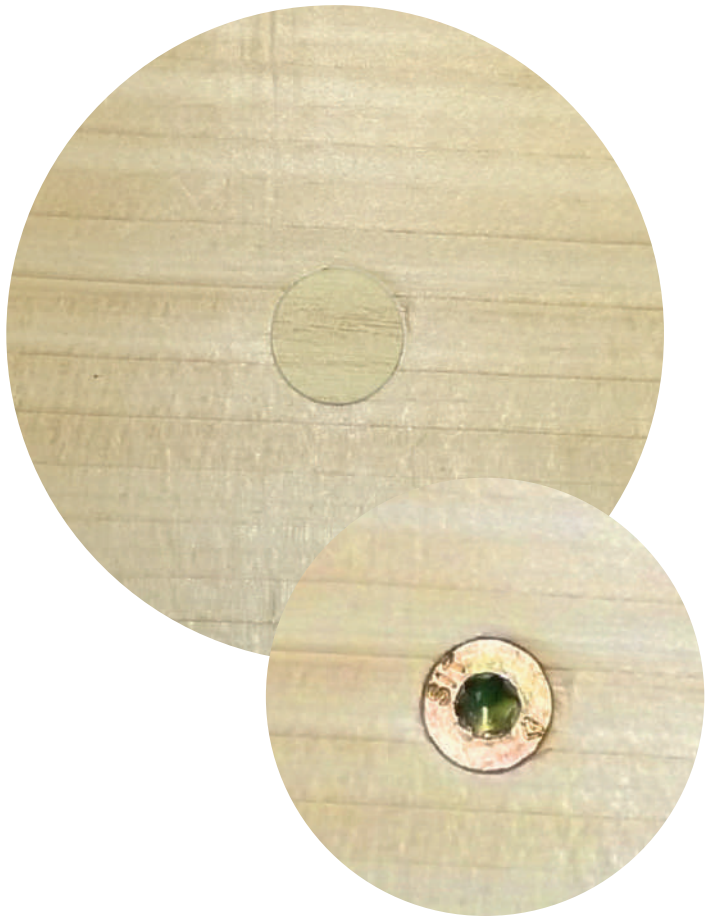

Approvals and certificates

HALOGEN
FREE

Matching the CELO countersunk screws



VELOX® SIT, p. 206



VELOX® Pozi, p. 210



Adjustment screw JS, p. 221



Hanger bolt EDR, p. 223



















BMax countersunk head, p. 216

Magic Tap















Magic Tap in blister

Type	Art-No	Colour*	Ø [mm]	€ / Blister	 [pcs]	 [Blister]
Magic Tap white	51MT20		13		20	10
Magic Tap beech tree	5HMT20		13		20	10
Magic Tap grey	5GRMT20		13		20	10
Magic Tap grained white	5WPMT20		13		20	10
Magic Tap black	54MT20		13		20	10
Magic Tap oak tree	5ROMT20		13		20	10
Magic Tap cherry tree	5CMT20		13		20	10
Magic Tap pine tree	5PIMT20		13		20	10
Magic Tap sapely	5SMT20		13		20	10
Magic Tap maple	5MAMT20		13		20	10
Magic Tap beige	5BEMT20		13		20	10
Magic Tap wenge	5WEMT20		13		20	10
Magic Tap walnut tree	5NOMT20		13		20	10
Magic Tap aluminium	5ALMT20		13		20	10

* Minor deviations of the colour possible



Magic Tap in big craftsman pack

Type	Art-No	Colour*	Ø [mm]	€ / 100 pcs	 [pcs]	 [pcs]
Magic Tap white	91MT		13		1.000	16.000
Magic Tap beech tree	9HMT		13		1.000	16.000
Magic Tap grey	9GRMT		13		1.000	16.000
Magic Tap grained white	9WPMT		13		1.000	16.000
Magic Tap black	94MT		13		1.000	16.000
Magic Tap oak tree	9ROMT		13		1.000	16.000
Magic Tap cherry tree	9CMT		13		1.000	16.000
Magic Tap pine tree	9PIMT		13		1.000	16.000
Magic Tap sapely	9SMT		13		1.000	16.000
Magic Tap maple	9MAMT		13		1.000	16.000
Magic Tap beige	9BEMT		13		1.000	16.000
Magic Tap wenge	9WEMT		13		1.000	16.000
Magic Tap walnut tree	9NOMT		13		1.000	16.000
Magic Tap aluminium	9ALMT		13		1.000	16.000

* Minor deviations of the colour possible

Small and Craftsman pack SIT[®]-Bits



Advantages



- SIT[®]-Bit for chipboard screws VELOX[®] SIT (=AW recess from Würth)
- Significantly improved working comfort, because the screw easily gets stuck on the bit and cannot tumble
- Perfect power transfer due to conical form; the SIT[®]-Bit centers itself, the flanks also transfer high screw-in moments optimally
- Minimal wear and tear of the bit due to perfect fit between bit and screw
- Robust plastic box with EURO-punching



SIT[®]-Bits

Type	Art-No	€/pc	€/Blister	[pcs]	[Blister]
SIT 10 Small pack	7USIT10			2	10
SIT 20 Small pack	7USIT20			2	10
SIT 25 Small pack	7USIT25			2	10
SIT 30 Small pack	7USIT30			2	10
SIT 40 Small pack	7USIT40			2	10
SIT 10 Craftsman pack	9USIT10			10	10
SIT 20 Craftsman pack	9USIT20			10	10
SIT 25 Craftsman pack	9USIT25			10	10
SIT 30 Craftsman pack	9USIT30			10	10
SIT 40 Craftsman pack	9USIT40			10	10

Other Bits



PH-Bits 1/4" x 25

Type	Art-No	€ / pc	€ / Blister	[pcs]	[Blister]
PH 1	9UH1			10	10
PH 2	9UH2			10	10
PH 3	9UH3			10	10



PZ-Bits 1/4" x 25

Type	Art-No	€ / pc	€ / Blister	[pcs]	[Blister]
PZ 1	9UZ1			10	10
PZ 2	9UZ2			10	10
PZ 3	9UZ3			10	10



TX-Bits 1/4" x 25

Type	Art-No	€ / pc	€ / Blister	[pcs]	[Blister]
TX 10	9UTX10			10	10
TX 15	9UTX15			10	10
TX 20	9UTX20			10	10
TX 25	9UTX25			10	10
TX 30	9UTX30			10	10
TX 40	9UTX40			10	10
TX 50	9UTX50			5	10



Duo-Bits for IPL 60

Type	Art-No	Dimensions	For use with	€ / pc	€ / Blister	[pcs]	[Blister]
TX20/TX40	7DTX20TX40	1/4" x 43 mm	IPL60 and TX20 screw			2	10
TX25/TX40	7DTX25TX40	1/4" x 43 mm	IPL60 and TX25 screw			2	10
PZ2/TX40	7DPZ2TX40	1/4" x 43 mm	IPL60 and PZ2 screw			2	10

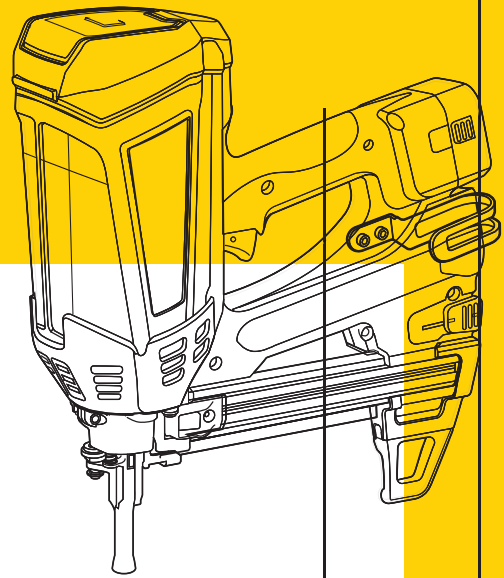

Gas nailers FORCE ONE and FOX

FORCE ONE



235

GAS FORCE ONE



238

XHA / TKA
FORCE ONE



239

FOX



241

GAS FOX



244

XHA / TKA FOX



245

SDS Plus



246

FOXMH



247

Gas nailer

FORCE ONE



**The best gas nailer in its class
- with extensive range of accessories**



Gas nailer FORCE ONE

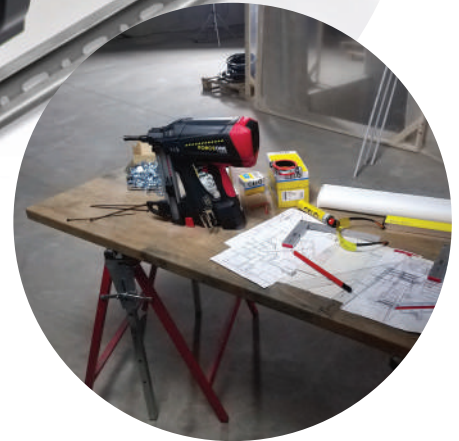

Advantages, approvals and certificates



Suitable building materials



Versatile use in different base materials such as steel, concrete, solid bricks and limited in wood. Can be used on floors, walls and ceilings.

Applications

Electrical Installations

Fastening of various light electrical installations [cables, conduits, cable channels, lamp suspensions etc.]

HVAC sector

Fixing of heating pipes, ventilation channels etc.

Drywall construction

Fastening of drywall profiles

On the façade / tunnel construction / motorways

Fastening of insulating mats, moisture-repellent foils, protective material for floor coverings, fleece

Technical data of gas nailer FORCE ONE

Characteristics	Technical data
Height	365 mm
Width	124 mm
Length	334 mm
Weight	3.6 Kg (with battery included)
Loading capacity	FORCE ONE 20: 20 + 2 nails* FORCE ONE 40: 40 + 2 nails*
Type of battery	NiMH-battery (battery lasts for 3000 nails)
Capacity of battery	6V DC, 1.5Ah
Power consumption (Rated output)	8VA (10V 800mA)
Connection charger	100-240V AC. (50 or 60Hz)
Charging time	max. 120 minutes
Temperature range for use	-10°C to +40°C

* There must be at least 3 nails in the magazine, otherwise the nailer cannot be triggered.



More information at www.celofixings.com

Main features / Advantages



ETA-approved system

when combining approved accessories, XHA-nails and premium gas nailer FORCE ONE



Powerful

Setting energy of 105 Joule for high fastening quality (steel thickness from 3,5 mm)



Constant power

Consistent gas injection regardless of temperature



Long lasting battery

up to 3000 fastenings per charge



Short contact pressure

enables fatigue-free working, especially with overhead installation



Quick

up to 2.5 nails per second



Good accessibility

even in narrow places due to the slim design and the extended nose



Lightweight

with only 3,6 kg including battery the FORCE ONE is the lightest gas nailer in its class



Highly effective dust protection

Clever filter systems at the suction and discharge openings



Ergonomic handle

relieves the hands during longer use



Very well balanced

due to the special positioning of the gas cartridge



Smart

Computer-controlled intelligent ventilator adapts to the environment



Simple and fast adjustable tool nose



Removable magazine footer



Versatile

nails from 13 to 38 mm length for many different applications



LED display

prevents unexpected work interruptions in case the battery is low

Set includes

- 1 x Gas nailer FORCE ONE
- 1 x Safety goggles
- 2 x Ear plugs
- 2 x Battery
- 1 x Charger
- 1 x Carrying case
- 1 x Jam clear tool
- 1 x Instruction manual



Gas nailer FORCE ONE

Type	Art-No	€/1 pc	[Set]	[pcs]
FORCE ONE with magazine for 20 nails	FONE20		1	-
FORCE ONE with magazine for 40 nails	FONE40		1	-



Battery and charger for gas nailer FORCE ONE

Type	Art-No	€/1 pc	[pcs]	[pcs]
FORCE ONE Battery	FONEBAT		1	-
FORCE ONE Charger	FONECARSET		1	-



High-performance gas for gas nailer FORCE ONE



Type	Art-No	Height [mm]	Content [ml]	Shelf life [months]	€/1 pc	[pcs]	[pcs]
Fuel cell*	9GASFONE	180	80	24		1	20

* sufficient for min. 800 nails

Steel nails FORCE ONE XHA & TKA

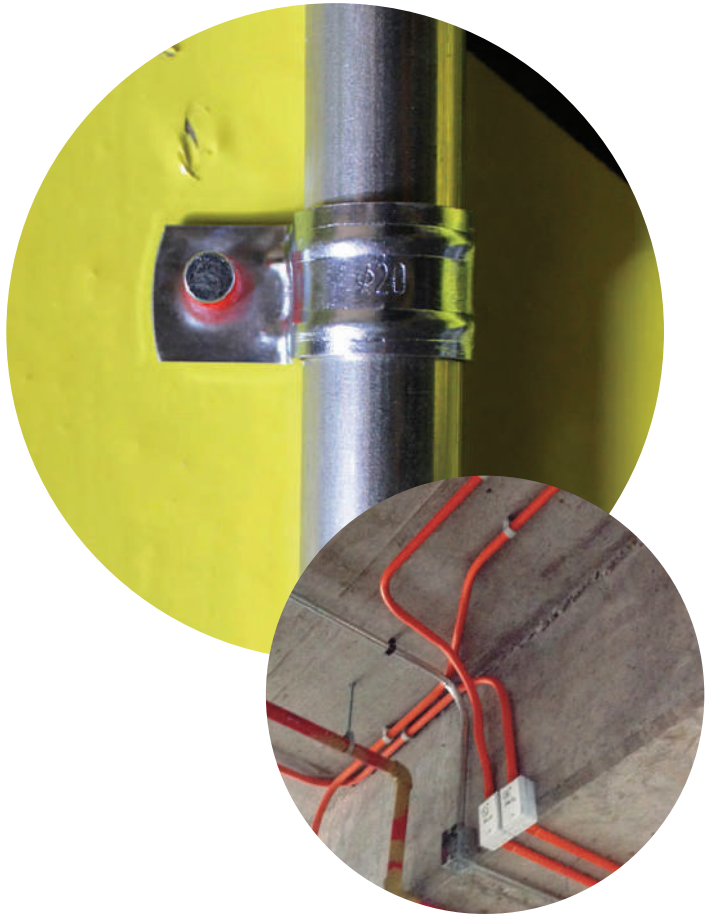

Advantages



XHA premium nails for gas nailer FORCE ONE



TKA standard nails for gas nailer FORCE ONE

- XHA:
 - Premium nails; suitable for hard concrete and steel
 - Nail 13 mm especially hardened for steel
 - Grooved nails to improve grip
- TKA: standard nails for concrete and solid bricks
- Each box includes one high-performance fuel cell, sufficient for 800 nails

Mounting

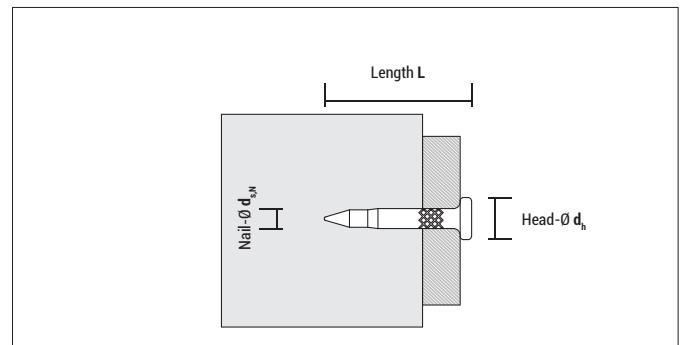

Approvals and certificates



when combining approved accessories, XHA-nails (22-38 mm) and FORCE ONE

XHA nails see assessment



XHA premium nails for FORCE ONE

+ each box includes one high-performance fuel cell



Type	Art-No	Nail-Ø $d_{s,N}$ [mm]	Length L [mm]	Head-Ø d_h [mm]	ETA	€/100 pcs	[pcs]	[pcs]
XHA premium nails 13 mm + fuel cell	913800XHA	3	13	6,3	—	—	800	4.000
XHA premium nails 17 mm + fuel cell	917800XHA	3	17	6,3	—	—	800	4.000
XHA premium nails 22 mm + fuel cell	922800XHA	3	22	6,3	●	—	800	4.000
XHA premium nails 27 mm + fuel cell	927800XHA	3	27	6,3	●	—	800	4.000
XHA premium nails 32 mm + fuel cell	932800XHA	3	32	6,3	●	—	800	4.000
XHA premium nails 38 mm + fuel cell	938800XHA	3	38	6,3	●	—	800	4.000

Steel nails FORCE ONE



+ each box includes one high-performance fuel cell



TKA standard nails for FORCE ONE

Type	Art-No	Nail-Ø d _{s,N} [mm]	Length L [mm]	Head-Ø d _h [mm]	€/100 pcs	[pcs]	[pcs]
TKA nails 19 mm + fuel cell	919800TKA	2,6	19	6,3		800	4.000
TKA nails 25 mm + fuel cell	925800TKA	2,6	25	6,3		800	4.000

Overview - Suitable building materials for nails XHA and TKA

	XHA 13 mm	XHA 17 mm	TKA 19 mm	XHA 22 mm	TKA 25 mm	XHA 27 mm	XHA 32 mm	XHA 38 mm
Steel (min. thickness 3,5 mm)	●							
Concrete > C20/25		●		○				
Concrete C20/25		○	●	●	●	○		
Solid brick		○	●	●	●	●	○	
Hollow brick					●	●	●	
Wood								●

● very suitable

○ suitable to a limited extent



Gas nailer

FOX



**The efficient gas nailer
for drywall construction**



Gas nailer FOX



Advantages, approvals and certificates



Suitable building materials



Designed for use it in different base materials such as concrete, steel, solid bricks and to a limited extend wood. Can be used on floors, walls, and ceilings.

Applications



Drywall construction
Fastening of drywall profiles.



Light- duty construction applications
For fixing drainage foils on walls.



Installations
For fixing conduits, cables and pipes on floors.

Technical data of gas nailer FOX

Characteristics	Technical data
Height	385 mm
Width	130 mm
Length	327 mm
Weight	3.8 Kg (battery included)
Loading capacity	FOX 20: 20 + 2 nails* FOX 40: 40 + 2 nails*
Type of battery	Li-Ion-battery (battery lasts for 8000 nails)
Capacity of battery	2.500 mAh
Connection charger	100-240V AC. (50 or 60Hz)
Charging time	90 min for full charge
Temperature range for use	0°C to 50°C

* There must be at least 3 nails in the magazine, otherwise the nailer cannot be triggered.

Main features / Advantages



85 Joule power
ensure good quality setting results



Gas power
2 nails per second;
high setting frequency



Highly effective dust protection
Clever filter systems at the suction and discharge openings



Fast recharge
A 2 minutes charge allows you to set at least another 200 nails



Ergonomic handle
relieves the hand during longer use



Demountable tool nose
for quick removal of jammed nail residues



Simple and fast depth adjustment
to adapt to various applications



Fast clearance of jammed nails
Quick release system



Laterally adjustable belt hook
for the right and left handed



Battery indicator
prevents a standstill at the construction site



Li-Ion battery
Up to 8.000 fastenings per charge



Versatile
Nails from 13 to 40 mm length for many different base materials

Set includes

- 1 x Gas nailer FOX
- 1 x Safety goggles
- 2 x Ear plugs
- 2 x Battery Li-Ion
- 1 x Charger
- 1 x Carrying case
- 1 x Instruction manual
- 1 x Allen wrench 4
- 1 x Allen wrench 5



Gas nailer FOX

Type	Art-No	€/1 pc	[Set]	[pcs]
FOX with magazine for 20 nails	FOX20		1	-
FOX with magazine for 40 nails	FOX40		1	-



Battery and charger for gas nailer FOX

Type	Art-No	€/1 pc	[pcs]	[pcs]
FOX Battery	FOXBAT		1	-
FOX Charger	FOXCARSET		1	-



High-performance gas for gas nailer FOX



Type	Art-No	Height [mm]	Content [ml]	Shelf life [months]	€/1 pc	[pcs]	[pcs]
Fuel cell*	91GASA	180	80	24		1	20

* sufficient for min. 1.000 nails

Steel nails FOX TKA & XHA



Advantages



TKA standard nails for gas nailer FOX



XHA premium nails for gas nailer FOX

- TKA:
 - standard nails for concrete and solid bricks
 - Nail 15 mm especially hardened for steel
- XHA:
 - Premium nails
 - Nail 13 mm especially hardened for steel
 - Grooved nails to improve grip
- Each box includes one high-performance fuel cell, sufficient for 1.000 nails

Mounting

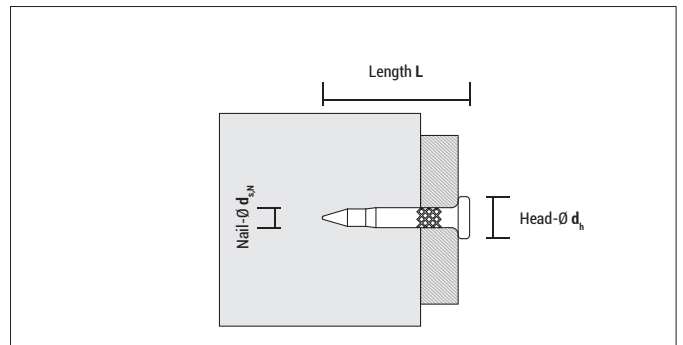

Approvals and certificates



XHA nails
see assessment



TKA standard nails for FOX

+ each box includes one high-performance fuel cell



Type	Art-No	Nail-Ø $d_{s,N}$ [mm]	Length L [mm]	Head-Ø d_h [mm]	€/100 pcs	[pcs]	[pcs]
TKA nails 15 mm + fuel cell	9151000TKA	2,6	15	6,3		1.000	5.000
TKA nails 19 mm + fuel cell	9191000TKA	2,6	19	6,3		1.000	5.000
TKA nails 25 mm + fuel cell	9251000TKA	2,6	25	6,3		1.000	5.000
TKA nails 30 mm + fuel cell	9301000TKA	2,6	30	6,3		1.000	5.000
TKA nails 40 mm + fuel cell	9401000TKA	2,6	40	6,3		1.000	5.000



+ each box includes one high-performance fuel cell

XHA premium nails for FOX

Type	Art-No	Nail-Ø d _{s,N} [mm]	Length L [mm]	Head-Ø d _h [mm]	€/100 pcs	[pcs]	[pcs]
XHA premium nails 13 mm + fuel cell*	9131000XHA	3	13	6,3		1.000	5.000
XHA premium nails 17 mm + fuel cell	9171000XHA	3	17	6,3		1.000	5.000
XHA premium nails 22 mm + fuel cell	9221000XHA	3	22	6,3		1.000	5.000
XHA premium nails 27 mm + fuel cell*	9271000XHA	3	27	6,3		1.000	5.000
XHA premium nails 32 mm + fuel cell*	9321000XHA	3	32	6,3		1.000	5.000
XHA premium nails 38 mm + fuel cell*	9381000XHA	3	38	6,3		1.000	5.000

* No stock item; only available on request



Pre-nailing drill bit SDS plus

Typ	Art-No	Drill bit length [mm]	Diameter [mm]	Outer-Ø [mm]	€/1 pc	[pc]	[pcs]
BSDS 5x10	510BSDS	10	5	14,2		1	-

Overview - Suitable building materials for XHA and TKA FOX

	XHA 13 mm	TKA 15 mm	XHA 17 mm	TKA 19 mm	XHA 22 mm	TKA 25 mm	XHA 27 mm	TKA 30 mm	XHA 32 mm	XHA 38 mm	TKA 40 mm
Steel (min. thickness 3,5 mm)	●	●									
Concrete > C20/25		●	●	○	○						
Concrete C20/25			○	●	●	●	○				
Solid brick			○	●	●	●	●	●	○	○	○
Hollow brick						●	●	●	●		
Wood										●	●

● very suitable ○ suitable to a limited extent

Magnetic holder for gas nailer FOX

FOXMH





Advantages



- Magnetic holder for FOX gas nailer- clips easily onto the nose of the tool
- Time and money saving as any kind of thin steel metal discs can be used with the magnetic holder
- Typical applications:
 - fixing expanded metal mesh to steel beams
 - fixing of any kind of foil, fleece or mesh





















FOXMH

Type	Art-No	Height H [mm]	Outer-Ø [mm]	Inner-Ø [mm]	€/ 1 pc	 [pcs]	 [pcs]
FOXMH	FOXMH	9,5	23,5	11,5		1	-



Gas nailer accessories

ABT		250	CHS		258
UT		251	PFT / DFT		259
TPC / TPLC		252	ATR		261
NCC		253	ATV		262
WSC / WDC		254	AAT		263
TBB		255	AW		264
TBBL		255	APK		266
TBBD		255	AP		265
TBM		255	TXS		267
FP / FPD		257			

Compatibility CELO gas nailer accessories

CELO

Accessories



when combining approved accessories, X-HA-nails (22-38 mm) and FORCE ONE

CELO gas nailers

FORCE ONE





























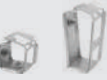

FOX



Suitable for



concrete screw BTS4

Accessories	ETA	CE	FORCE ONE	FOX	Suitable for
XHA 	•	•	✓	✓	X
TKA 	•	•	✓	✓	X
GASFONE 	•	•	✓	X	X
GASA FOX 	•	•	X	✓	X
ABT 	•	•	✓	✓	X
UT 	•	•	✓	✓	X
TPC/TPLC 	•	•	✓	✓	X
NCC 	•	•	✓	✓	X
WSC 	•	•	✓	✓	X
WDC 	•	•	✓	✓	X
TBB 	•	•	✓	✓	X
NTBB 	•	•	X	X	X
TBL 	•	•	✓	✓	X
TBD 	•	•	✓	✓	X
TBM 	•	•	✓	✓	X
FP 	•	•	✓	✓	X
FPD 	•	•	✓	✓	X
CHS 	•	•	✓	✓	✓
PFT 	•	•	✓	✓	✓
DFT 	•	•	✓	✓	✓
ATR M6 	•	•	✓	✓	X
ATR M8 	•	•	✓	✓	X
ATV 	•	•	✓	✓	X
ATVS 8 	•	•	✓	✓	X
AAT 	•	•	✓	✓	X
AW 	•	•	✓	✓	X
AP 	•	•	✓	✓	X
APK 	•	•	✓	✓	X
TXS 	•	•	✓	✓	X
CA 	•	•	✓	✓	X

Multidiameter nylon clamp Abranyl® ABT



Advantages



- Fast installation in 3 seconds with gas nailer FORCE ONE and FOX. The clamp closes automatically when the pipe is pushed in.
- Multidiameter: One clamp size covers three pipe diameters
- UL-tested
- Halogen free
- RoHS compliant
- With alignment marking
- Black version: UV-resistant

Approvals and certificates



Mounting

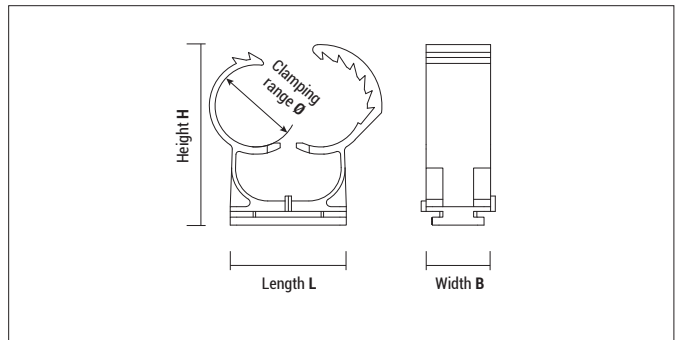

Type	Clamping range Ø [mm]	Length L [mm]	Height H [mm]	Width B [mm]
ABT 14/18	14-18	24,0	35,6	20
ABT 20/25	20-25	29,0	45,5	20
ABT 26/32	26-32	36,0	53,6	20
ABT 35/42	35-42	45,0	66,4	20



ABT

Type Ø	Art-No		Art-No			Pipe-Ø				ETA	[pcs]	[pcs]
	grey	€/ 100 pcs	black	white	€/ 100 pcs	Metric [mm]	Copper [mm]	Steel [inch]	Plastic [mm]			
ABT 14/18	918ABT		9418ABT	9118ABT		16	14-15-18	3/8"	16	●	100	600
ABT 20/25	925ABT		9425ABT	9125ABT		20-25	22	1/2"	20-25	●	50	450
ABT 26/32	932ABT		9432ABT	9132ABT		32	28	3/4"	32	●	50	300
ABT 35/42	942ABT		9442ABT	9142ABT		40	35-42	1"-1/4"	40-42	●	25	150

Compatible gas nailers can be found on page 249

Pipe ring clip UT



Advantages



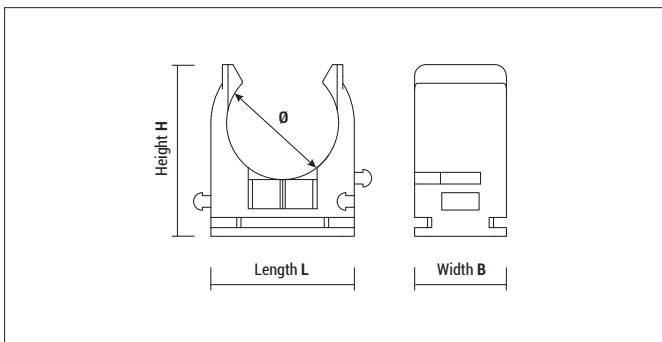

- Fast installation with gas nailer FORCE ONE and FOX
- UT clips can be mounted in series due to lateral slots
- A marking allows quick alignment
- Halogen free
- RoHS compliant

Mounting



UT

Type	Art-No	Pipe-Ø Plastic [mm]		€/ 100 pcs	 [pcs]	 [pcs]
UT 16	916UT	16	●		100	900
UT 20	920UT	20	●		100	900
UT 25	925UT	25	●		100	900
UT 32	932UT	32	●		50	450
UT 40	940UT	40	●		50	300

Approvals and certificates



Type	Ø [mm]	Length L [mm]	Height H [mm]	Width B [mm]
UT 16	15,5	23,0	25,5	16,0
UT 20	19,5	25,0	29,5	16,0
UT 25	24,5	30,5	34,0	16,0
UT 32	31,0	38,0	42,0	16,0
UT 40	39,0	46,0	50,0	16,0

Compatible gas nailers can be found on page 249

Nylon clip for flat cables

TPC & TPLC



Advantages



- Perfectly suited for fixing flat cables

Mounting



Approvals and certificates

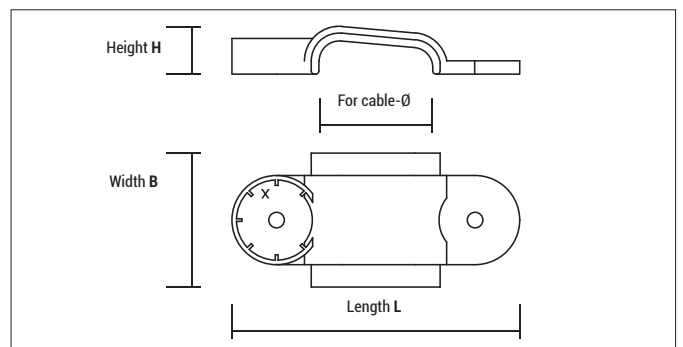

TPC, TPLC

Type	Art-No	For cable-Ø [mm]	Length L [mm]	Width B [mm]	Height H [mm]	€/ 100 pcs	[pcs]	[pcs]
TPC 6x17	9TPC	6x15	44,0	22,0	7,5		100	900
TPLC 9x25	9TPLC	9x25	64,5	30,0	10,5		100	900

Compatible gas nailers can be found on page 249

Nailing Cable Clasp

NCC



Advantages



NCC 16 for 16 cables

NCC 8 for 8 cables

NCC 4 for 4 cables

- Quick nailing installation of multiple cables
- Developed exclusively for direct impact fixing with a nailer, without a plug and screw. Compatibility with FORCE ONE and FOX
- Easy cable adding and removing for time saving
- Flat design that allows a tight and organized cable distribution, saving space
- Designed in three sizes for fixing 4, 8, or 16 Ø8 mm cables
- Open design with windows that enables additional cable holding with cable ties
- Fixing compatibility for cables from 6 mm to 10 mm diameter
- Made with ageing and weather-resistant nylon
- Halogen free
- RoHS compliant

Mounting

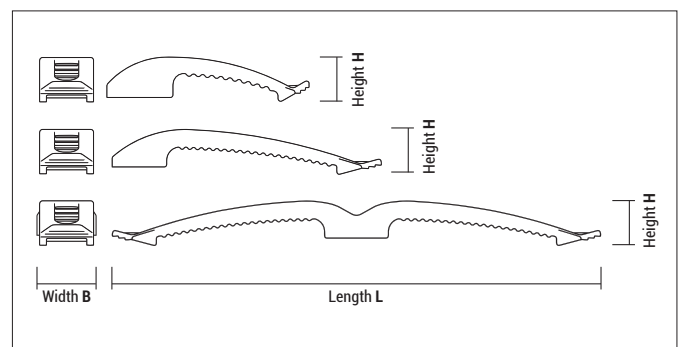

Approvals and certificates



NCC

Type	Art-No	Length L [mm]	Height H [mm]	Width B [mm]	Cable capacity			€/100 pcs	[pcs]	[pcs]
					Ø6	Ø8	Ø10			
NCC 4	94NCC	75	15	20	6	4	3		100	9.600
NCC 8	98NCC	121	17	20	12	8	6		100	8.000
NCC 16	916NCC	222	17	22	24	16	12		50	4.000

Compatible gas nailers can be found on page 249

Wire conduit WSC & WDC

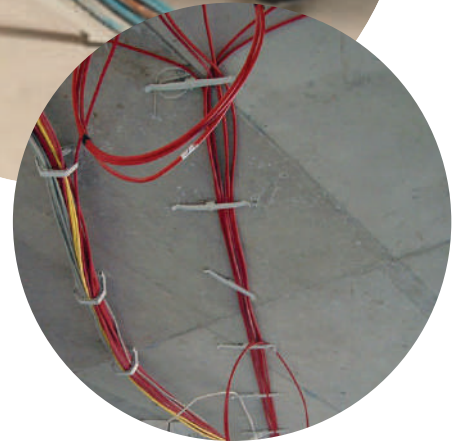
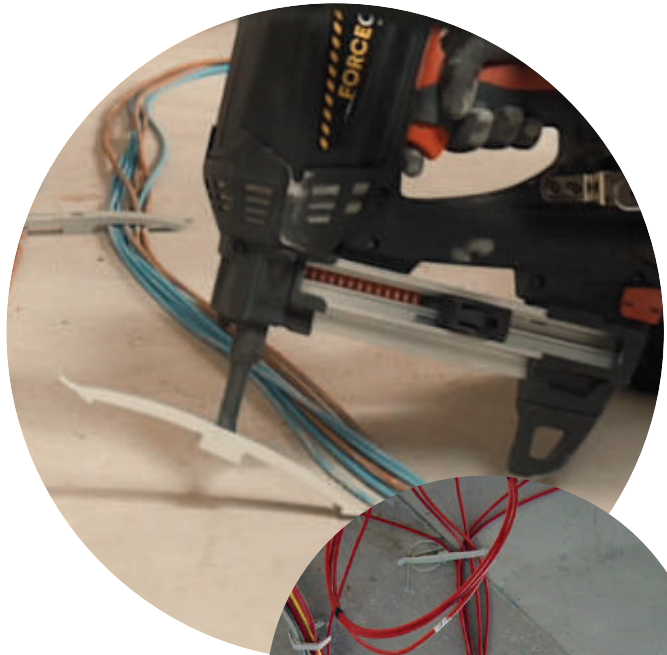

Advantages



- Versatile in use
- Simply push the cable under the wing
- Several cables can be secured with only one fixing point
- Can also be fixed with a plug Ø6 or a nail plug
- RoHS compliant
- Halogen free

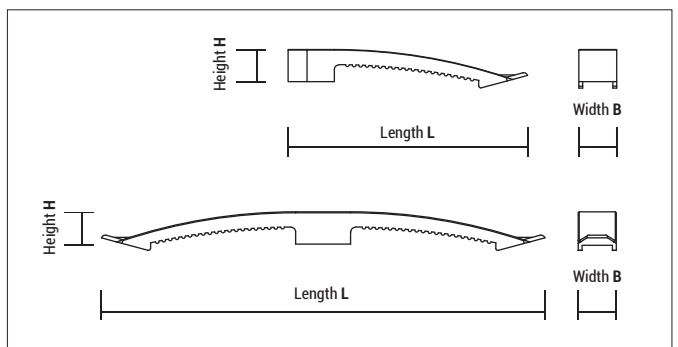
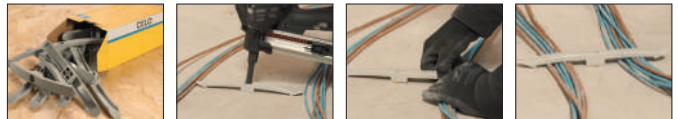

Mounting



Approvals and certificates



WSC / WDC

Type	Art-No	Length L [mm]	Width B [mm]	Height H [mm]		€/ 100 pcs	 [pcs]	 [pcs]
WSC	9WSC	128	20	17	●		100	900
WDC	9WDC	232	20	17	●		50	450

Compatible gas nailers can be found on page 249

Cable tie fasteners

TBB, TBBL, TBBB, TBM



Advantages

- Rounded shape enables self-centering the pipe / cable
- Easy mounting of lightweight cables and conduits
- Can be used flexibly, as it is suitable for various pipe diameters
- Halogen free
- RoHS compliant

Approvals and certificates



TBB

Mounting TBB

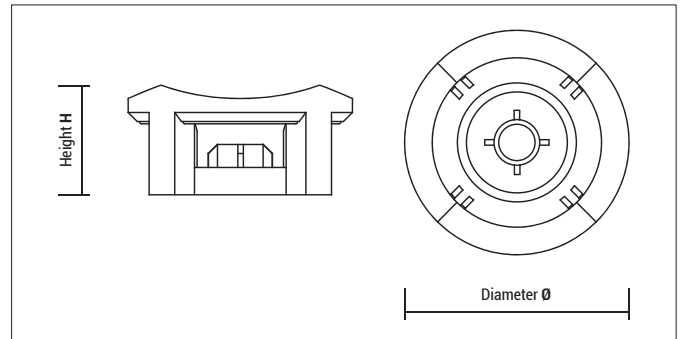

TBB for FORCE ONE & FOX



Type	Art-No	Height H [mm]	Diameter Ø [mm]	ETA	€/100 pcs	[pcs]	[pcs]
TBB black	9TBB	13	24,5	●		100	1.200
TBB grey	9GRTBB	13	24,5	●		100	1.200

Compatible gas nailers can be found on page 249



NTBB

Type	Art-No	Height H [mm]	Diameter Ø [mm]	€/100 pcs	[pcs]	[pcs]
NTBB grey	9NTBB	13	24,5		100	1.200

Compatible gas nailers can be found on page 249

TBBL





TBBL black

TBBL grey

Mounting TBBL



TBBL

Type	Art-No	Length L [mm]	Width B [mm]	Height H [mm]		€/ 100 pcs	 [pcs]	 [pcs]
TBBL black	94TBBL	33	20	10	●		200	-
TBBL grey	9TBBL	33	20	10	●		200	-

Each box includes 200 pcs cable tie 4,8 x 288
Compatible gas nailers can be found on page 249

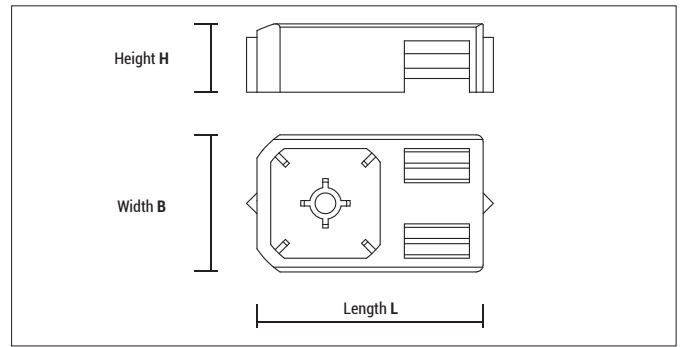

when combining approved accessories, XHA-nails (22-38 mm) and FORCE ONE



TBBD



Mounting TBBD



TBBD

Type	Art-No	Length L [mm]	Width B [mm]	Height H [mm]	€/ 100 pcs	 [pcs]	 [pcs]
TBBD	9TBBD	80	18	9,5		100	600

Compatible gas nailers can be found on page 249

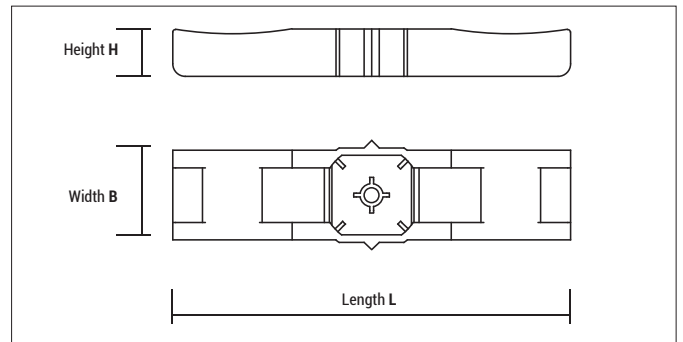

TBM



TBM: metal version with 6 mm hole for fixing with a screw or a plug.

TBM

Type	Art-No	Length L [mm]	Width B [mm]	Height H [mm]	Clearance hole Ø [mm]	€/ 100 pcs	 [pcs]	 [pcs]
TBM	9TBM	51	25	12,5	6		100	900

Compatible gas nailers can be found on page 249

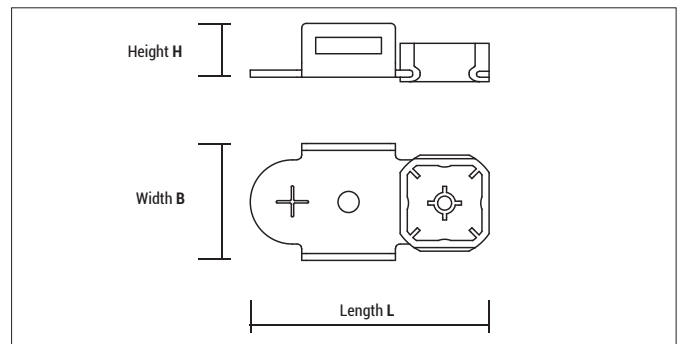

Conduit clips

FP & FPD

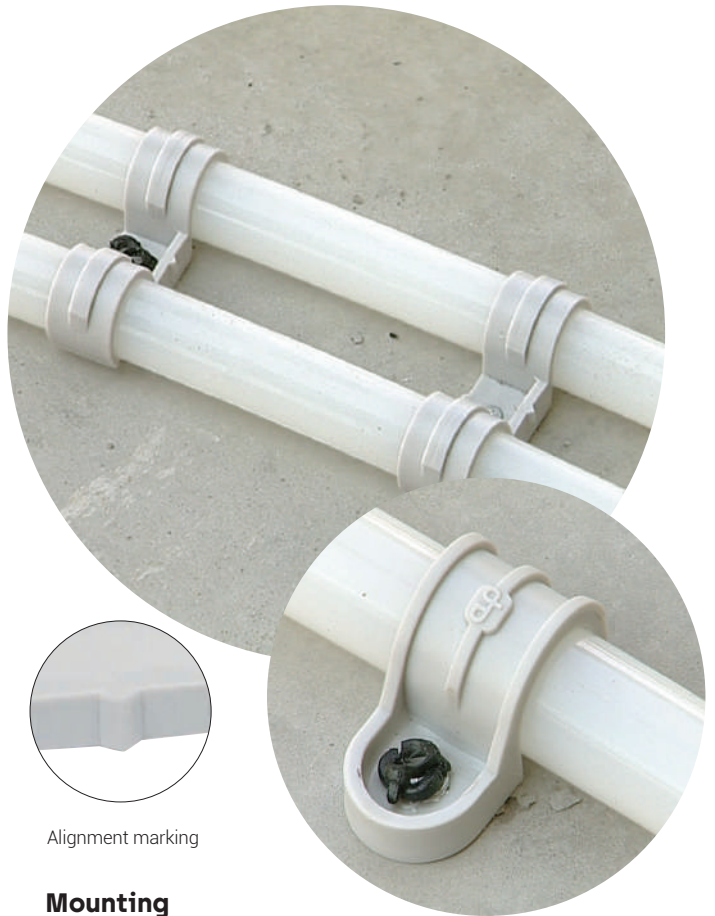

Advantages



FP single

FPD double

- Multidiameter: Each clip covers 3 pipe diameters
- Also suitable for flexible empty tubes on the floor
- Flexible use, **as compatible with every gas nailer**
- The alignment marking of the FPD supports the installation of cables in a straight line
- Halogen free



Alignment marking

Mounting



Approvals and certificates



when combining approved accessories, XHA-nails (22-38 mm) and FORCE ONE



FP

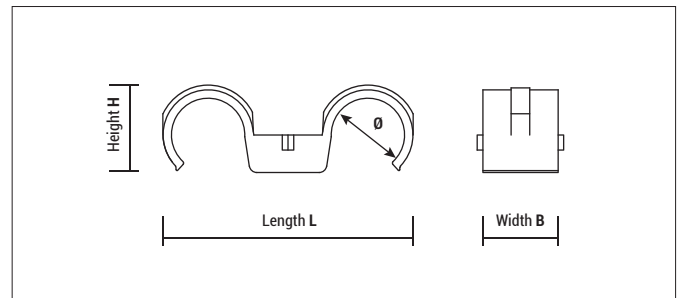

Type	Art-No	Pipe-Ø			Length L [mm]	Width B [mm]	ETA	€/100 pcs	Box [pcs]	Pallet [pcs]
		Metric [mm]	Copper [mm]	Steel [inch]						
FP 16	916FP	16	-	-	41,5	23	●		100	900
FP 18	918FP	-	18	3/8"	43,5	23	●		100	900
FP 20	920FP	20	-	-	45,5	23	●		100	600
FP 22	922FP	-	22	1/2"	47,5	23	●		100	600
FP 25	925FP	25	-	-	50,5	23	●		100	600
FP 28	928FP	-	28	3/4"	53,5	23	●		100	600
FP 32	932FP	32	-	-	57,5	23	●		50	450

Compatible gas nailers can be found on page 249



FPD

Type	Art-No	Pipe-Ø			Pipe sizes [mm]	Length L [mm]	Width B [mm]	Height H [mm]	ETA	€/100 pcs	Box [pcs]	Pallet [pcs]
		Copper [mm]	Steel [inch]	Plastic [mm]								
FPD 16	916FPD	18	3/8"	16	16 - 19	59	20	19,5	●		100	900
FPD 20	920FPD	22	1/2"	20	20 - 23	68	20	23,8	●		50	450
FPD 25	925FPD	28	3/4"	25	25 - 28	81	20	29	●		50	450

Compatible gas nailers can be found on page 249

Metal cable hanger

CHS



Advantages



CHS 47x41

CHS 35x87

- Quick system for installing electrical cables of different diameters
- Allows to extend the installation of cables easily and quickly thanks to the lateral opening of the clamp
- Can be used both on ceilings and walls
- Clip for easy attachment to the nose of the gas nailer; quick handling
- Pending fire resistance approval R90
- Increased distance between fixing points saves time and money during the installation process
- Suitable for cable harnesses, cables in escape routes like emergency lighting, smoke ventilation systems etc.
- Sendzimir zinc plated clamp
- CHS small is suitable for 15 cables of 3x1,5 mm and CHS large for 30 cables of 3x1,5mm

Mounting

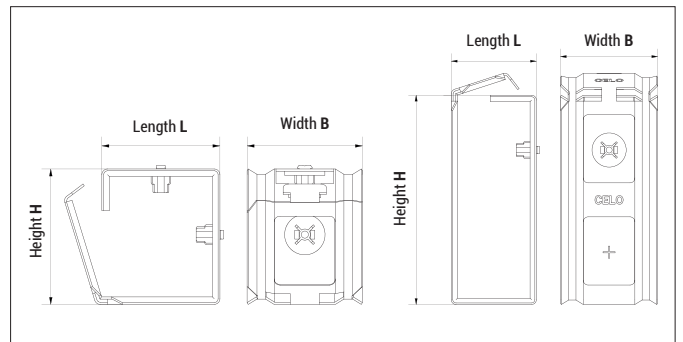

Approvals and certificates



when combining approved accessories, XHA-nails (22-38 mm) and FORCE ONE

see assessment

CHS

Type	Art-No.	Length L [mm]	Width B [mm]	Height H [mm]	Cable capacity			ETA	€/100 pcs	[pcs]	[pcs]
					Ø6	Ø8	Ø10				
CHS 47x41	94741CHS	47	40	41	30	15	12	●		100	-
CHS 35x87	93587CHS	35	40	87	40	30	20	●		50	-

Compatible gas nailers can be found on page 249

Recommended loads F_{rec} [kN]

Distance between clamps [mm]	300	400	500	600	700	800
Maximum recommended load per clamp (kg)	6 ¹⁾	4,5	3,6	3	2,6	2,3

¹⁾ The maximum load capacity is 6 kg/m.

It is recommended to install with a spacing of 300 mm to 600 mm, depending on the stiffness of the cable.

Metal conduit clip PFT & DFT

Advantages



PFT single



DFT double

- Simple and quick mounting option for fire alarm cables, cables or pipes
- Very fast installation of electric cables, flexible and rigid cable conduits, water and heating pipes
- Support rib for high stability of the clip and secure hold

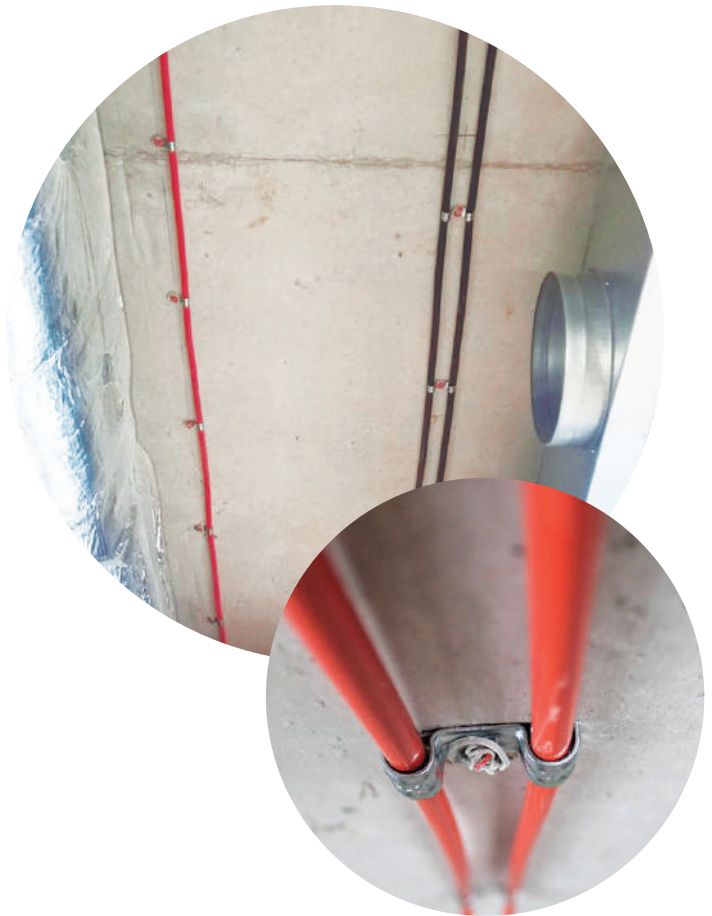

Approvals and certificates



see assessment



when combining approved accessories, XHA-nails (22-38 mm) and FORCE ONE

Mounting

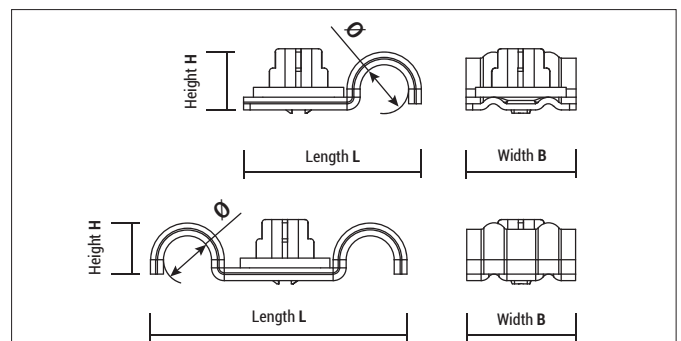

Metal conduit clip PFT & DFT



PFT

Type	Art-No	Diameter Ø	Length L [mm]	Width B [mm]	Height H [mm]	Pipe-Ø				€/100 pcs	 [pcs]	 [pcs]
		[mm]				Copper [mm]	Plastic [mm]	Cables [mm]				
PFT 5	95PFT	4,5	24	17	3,8	-	-	1x1.5 / 2x0.75	●		100	1.800
PFT 6	96PFT	6	26	17	5,5	6	-	1x1,5 / 1x2,5	●		100	1.800
PFT 7	97PFT	6,5	26,5	17	6	-	-	1x1,5 until 1x6	●		100	1.800
PFT 8	98PFT	7,5	27,5	17	7	8	-	1x6 / 1x10	●		100	1.800
PFT 10	910PFT	9,5	29,5	17	9	10	-	1x16 until 4x1,5	●		100	1.800
PFT 12	912PFT	11,5	31,5	17	11,5	12	-	1x25 until 4x2,5	●		100	900
PFT 14	914PFT	13,5	33,5	17	13,5	15	-	4x6	●		100	900
PFT 16	916PFT	15,5	34,5	17	15,0	-	16	-	●		100	900
PFT 18	918PFT	17,5	36,5	17	17,0	18	-	-	●		100	900
PFT 20	920PFT	19,5	38,5	17	18,5	-	20	-	●		100	900
PFT 22	922PFT	21,5	40,5	17	20,5	22	-	-	●		100	900
PFT 25	925PFT	24,5	43,5	17	23,5	-	25	-	●		100	900
PFT 28	928PFT	27,5	46,5	17	26,5	28	-	-	●		100	900
PFT 32	932PFT	31,5	50,5	17	30,5	35	32	-	●		100	600
PFT 40	940PFT	39,5	58,5	17	38,5	42	40	-	●		50	450
PFT 50	950PFT	49,5	68,5	17	48,5	-	50	-	●		50	450

Compatible gas nailers can be found on page 249



DFT

Type	Art-No	Diameter Ø	Length L [mm]	Width B [mm]	Height H [mm]	Pipe-Ø				€/100 pcs	 [pcs]	 [pcs]
		[mm]				Copper [mm]	Plastic [mm]	Cables [mm]				
DFT 5	95DFT	4,5	34	17	3,8	-	-	1x1.5 / 2x0.75	●		100	1.800
DFT 6	96DFT	6	37	17	5,5	6	-	1x1,5 / 1x2,5	●		100	900
DFT 7	97DFT	6,5	37	17	6	-	-	1x1,5 until 1x6	●		100	1.800
DFT 8	98DFT	7,5	40	17	7	8	-	1x6 / 1x10	●		100	900
DFT 10	910DFT	9,5	44	17	9	10	-	1x16 until 4x1,5	●		100	900
DFT 12	912DFT	11,5	48	17	11,5	12	-	1x25 until 4x2,5	●		100	900
DFT 16	916DFT	15,5	56	17	15	-	16	-	●		100	600
DFT 18	918DFT	17,5	60	17	17	18	-	-	●		100	600
DFT 20	920DFT	19,5	64	17	18,5	-	20	-	●		50	450
DFT 22	922DFT	21,5	68	17	20,5	22	-	-	●		50	450
DFT 25	925DFT	25,5	74	17	23,5	-	25	-	●		50	450
DFT 28	928DFT	27,5	80	17	26,5	28	-	-	●		50	450
DFT 32	932DFT	32	88	17	30	35	32	-	●		50	300

Compatible gas nailers can be found on page 249

Stud accessory ATR



Advantages

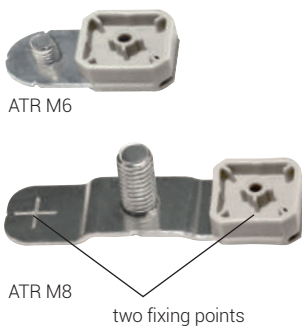

- Stable design ensures high resistance
- Marking enables quick alignment

Approvals and certificates



Type	Thread	Length connecting thread	Rec. Loads
ATR 6	M6	6,5	30 kg
ATR 8	M8	10/16	50 kg



Mounting

ATR 6



ATR 8

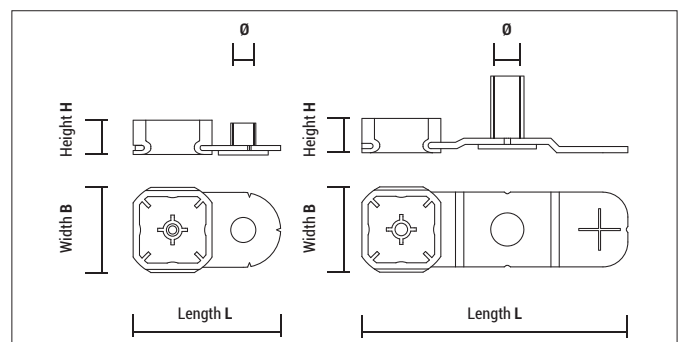

ATR

Type	Art-No	Length L [mm]	Width B [mm]	Height H [mm]	Dimensions Thread x Length	Number of fixing points	ETA	€/100 pcs	[pcs]	[pcs]
ATR 6	9TR6	36	20,5	8	M6x6,5	1	●	100	900	
ATR 8C	9TR8C	64	20,5	8	M8x10	2	●	100	900	
ATR 8L	9TR8L	64	20,5	8	M8x17	2	●	100	900	

Compatible gas nailers can be found on page 249

Rod hanger ATV

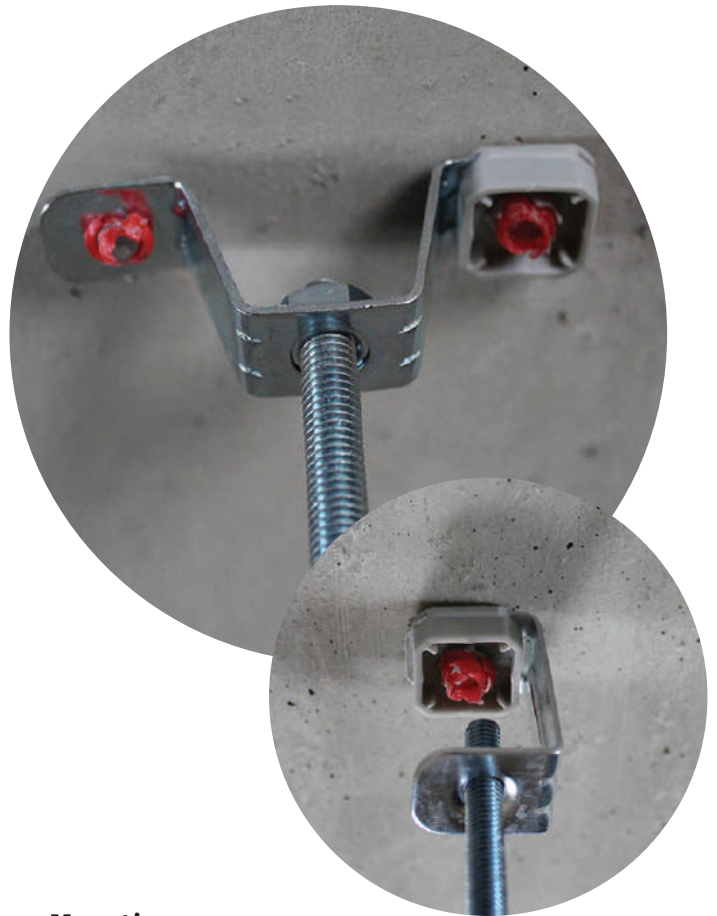

Advantages



ATV M4 - M6



ATV M8
with height adjustment



ATVS M8

- Fast mounting with gas nailer FORCE ONE and FOX
- Metric connecting thread for installation with anchor rod
- ATV M8: Easy and quick adjustment of the anchor rod

Mounting

ATV M4 - M6



ATV M8



Approvals and certificates



see assessment



when combining approved accessories, XHA-nails (22-38 mm) and FORCE ONE



ATV, ATVS

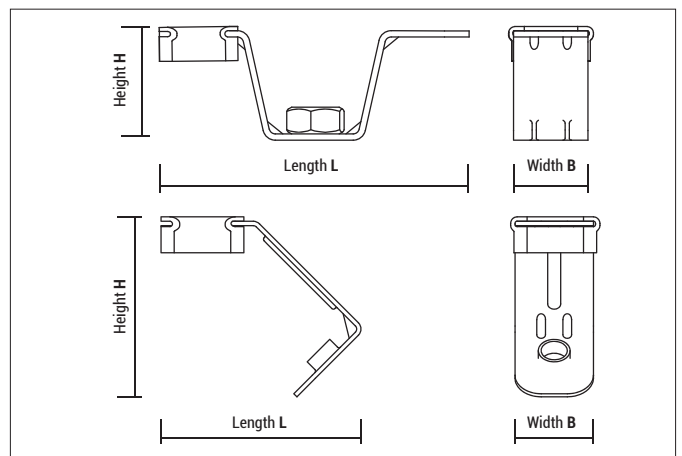

Type	Art-No	Metric thread	Length L [mm]	Width B [mm]	Height H [mm]		€/ 100 pcs	[pcs]	[pcs]
ATV M4	9TV4	M4	46	18	41	●		100	600
ATV M5	9TV5	M5	46	18	41	●		100	600
ATV M6	9TV6	M6	46	18	41	●		100	600
ATV M8	9TV8	M8	75	18	26,5	●		50	450
ATVS M8	9TVS8	M8	75	18	26,5	●		50	450

Ceiling hanger AAT



Advantages



- Very fast mounting in 10-15 seconds
- Clearance hole \varnothing 7 mm
- Fixing of steel cables for suspension of signs, lighting and suspended ceilings

Approvals and certificates



when combining approved accessories, XHA-nails (22-38 mm) and FORCE ONE

see assessment

Mounting

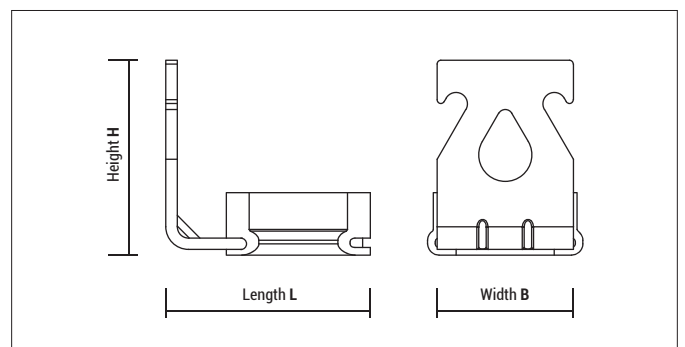

AAT

Type	Art-No	Height H [mm]	Length L [mm]	Width B [mm]	ETA	€/ 100 pcs	[pcs]	[pcs]
AAT	9AAT	27	26	19	●		100	900

Compatible gas nailers can be found on page 249

Metal washer

AW



Advantages



AW 15

AW 25

- Fast fixing of cable ducts, foils, meshes, sealing membranes, fleece etc.
- Metal Washer clamps on the nose of the gas nailer FORCE ONE and FOX and can therefore be installed with one hand
- Available in two different diameters

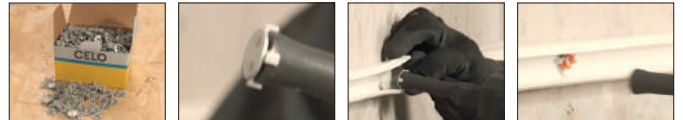

Mounting

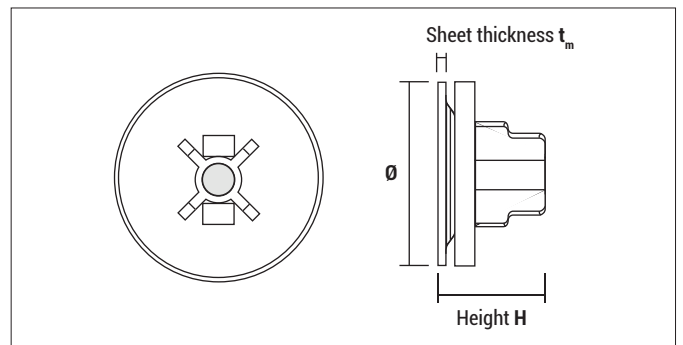

Approvals and certificates



AW

Type	Art-No.	Diameter Ø [mm]	Height H [mm]	Sheet thickness t_m [mm]	€/ 100 pcs	 [pcs]	 [pcs]
AW 15	915AW	15	5	1		200	3.600
AW 25	925AW	25	5	0,8		200	3.600

Compatible gas nailers can be found on page 249

Plastic washer

AP



Advantages



- AP Ø 16:
 - fixing of cable channels etc.
- AP Ø 30:
 - Plastic washer for fixing foils and fleece etc.
 - Larger load-bearing contact surface which increases the hold of the fixing

Mounting



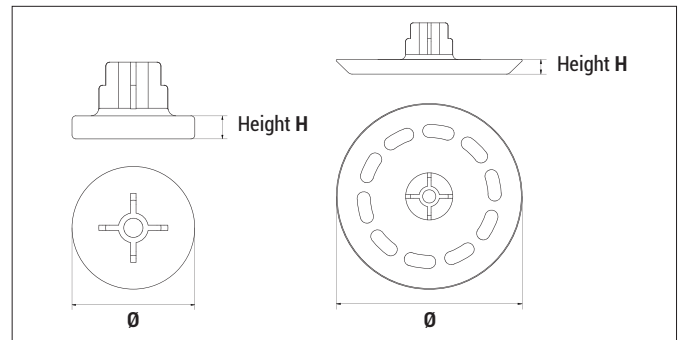

Approvals and certificates

HALOGEN
FREE



AP

Type	Art-No	Diameter Ø [mm]	Height H [mm]	€/100 pcs	 [pcs]	 [pcs]
AP 16	16AP	16	3		100	1.000
AP 30	30AP	35,5	2,75		100	1.000

Compatible gas nailers can be found on page 249

Plastic washer APK



Advantages



- Fixing of cable ducts, junction boxes and more in a matter of seconds
- The small pin on the underside of the disc fits precisely into the pre-punched holes in cable ducts and can therefore be ideally centred
- Easy to handle, fast fixing to the nose piece of FORCE ONE and FOX gas nailer
- Virtually dust-free installation
- Ideal for brittle plastic cable ducts

Mounting

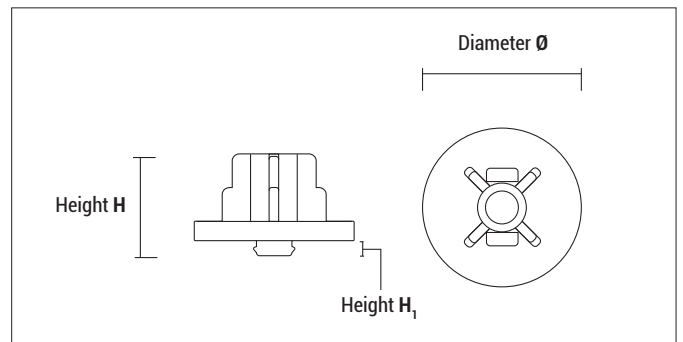

APK

Type	Art-No	Diameter Ø [mm]	Height H [mm]	Height H ₁ [mm]	€/100 pcs	[pcs]	[pcs]
APK	914APK	14	9	2,4		500	9.000

Compatible gas nailers can be found on page 249

Black textile strip 19 mm

TXS

Advantages



- Fast and cost-effective fastening of flexible empty tubes
- Several pipes or conduits can be mounted at the same time; parallel mounting is possible
- No damage to the pipe due to the absence of sharp edges
- Prevents breakage of corrugated pipe when the pipe is stretched
- Corrosion resistant
- Made of PES (Polyester) and withstands temperatures from -40 °C to +170 °C with a maximum load of 5 kN
- Very tearproof
- Easy to cut
- Rolls of 10 metres
- Suitable fixing pipes to floors for plumbing and heating installations, for harnesses and conduits and light pipes



Approvals and certificates

HALOGEN
FREE

Mounting

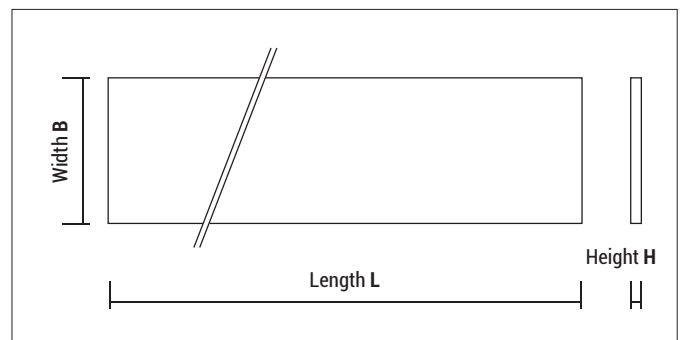





TXS black

Type	Art-No.	Height H [mm]	Length L [mm]	Width B [mm]	€/ 100 pcs	 [pcs]	 [pcs]
TXS black	9419TXS	1,25	10.000	19		8	-

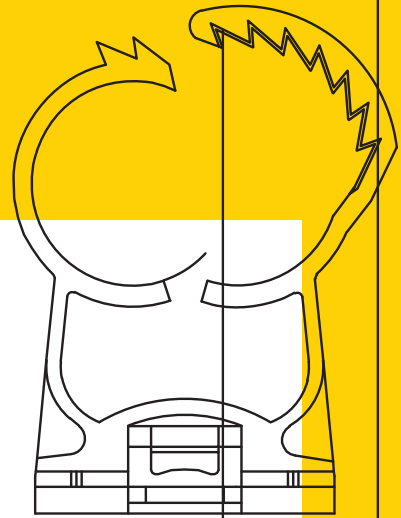
Compatible gas nailers can be found on page 249

Plastic Clamps

















AN		271
ABT		273
ABM		272
MC		273
UT		274

Overview of plastic clamps



Plastic clamps

	Abranyl® AN	Abranyl® ABT	Abranyl® ABM	Multiclip MC	Multiclip UT
Diameter Ø (mm)	12-50	14-42	10-42	16-40	16-40
Base	Nylon	Nylon	Nylon	Polypropylene	Nylon
Temperature range °C	-10°C to +90°C (at peaks of -25°C to +110°C)	-10°C to +90°C (at peaks of -25°C to +110°C)	-10°C to +90°C (at peaks of -25°C to +110°C)	-20°C to +100°C (at peaks of -30°C to +120°C)	-10°C to +90°C (at peaks of -25°C to +110°C)
Tension load (kg)	60	60	60	10	10
 European Technical Approval/Assessment (ETA)	X	 <small>when combining approved accessories, X+HA-nails (22-38 mm) and FORCE ONE</small>	X	X	 <small>when combining approved accessories, X+HA-nails (22-38 mm) and FORCE ONE</small>
 Black colour: UV-resistant	X	✓	✓	X	X
 Halogen free	✓	✓	✓	✓	✓
 RoHS compliant	✓	✓	✓	✓	✓
 Kiwa approval	✓	✓	✓	X	X
 UL certificate	X	✓	X	X	X
 Patented clamp	X	✓	✓	X	X
Absorption of stretching	✓	✓	✓	X	X
Multidiameter	✓ 2 diameters per size except for Ø 10, 12, 14	✓ 3 diameters per size	✓ 3 diameters per size	X	X
Fast installation with:	 Nail plug NP	 Gas nailer FORCE ONE and FOX	 Tacomax®	 Nail plug NP	 Gas nailer FORCE ONE and FOX
 Mounting with metric thread	✓ M6	X	✓ with Insermax®	X	X
Parallel mounting possible	X	X	X	✓	✓
Applications	Electrical and sanitary	Electrical and sanitary	Electrical and sanitary	Electrical	Electrical
page	271	273	272	273	274

Plastic clamp Abranyl®

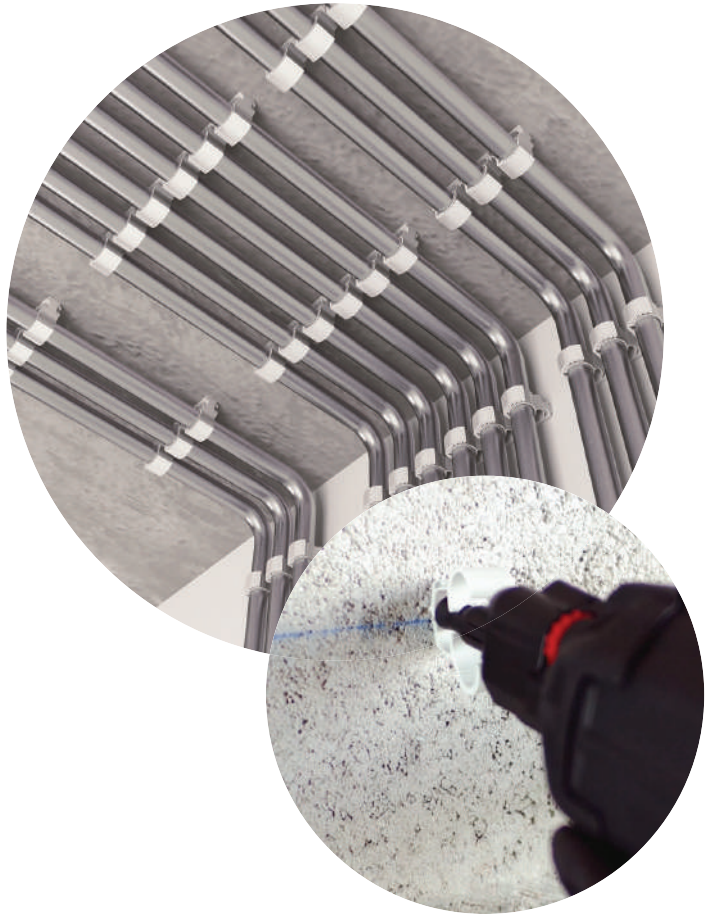

Advantages



- The clamps close automatically when the pipe is pushed in; you save time and money
- Various installations with screws, nail plugs, Tacomax® or Insermax®
- Approved by KIWA; clamp can be used for warm water pipes with temperatures up to 90°C
- High application reliability
- Black colour: UV-resistant

Approvals and certificates

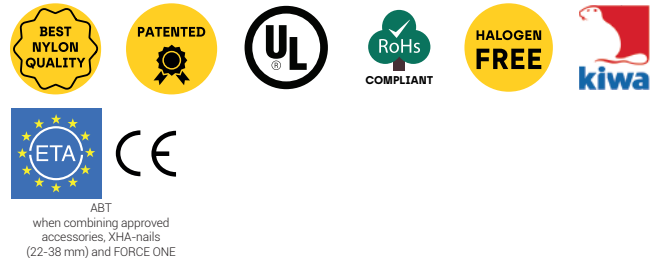

Mounting



Installation possibilities

Type	with plug and screw ¹	with profiles ²	with nail plugs ³	with Tacomax®	with Insermax®	with gas nailer FORCE ONE	Notes
AN	●	●	●	-	-	-	Sold millions of times, wellaccepted in the market
ABM	●	●	○	●	●	-	Best clamp for a wide range of installation due to its versatility
ABT	○	●	-	-	-	●	Preferred clamp for larger projects; great speed of installation with gas nailer

● Very suitable ○ Suitable

¹ With Plug Ø6 like FX 6, MZK 6 etc.

² With CELO-profiles e.g. PVC 1000, E2000PG, E2000PB

³ With Nail plug NP 5x35

Advantages Abranyl® AN Classic



- Multidiameter: one clamp size covers two pipe diameters



AN Classic

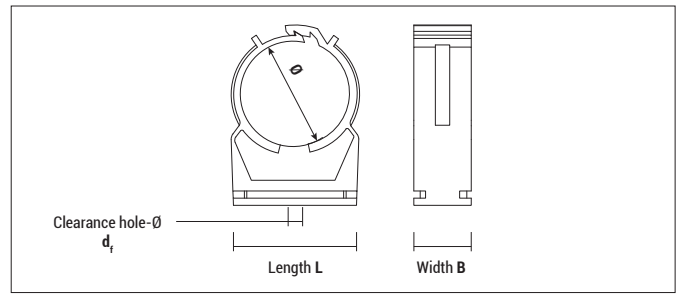

Type	Ø [mm]	d _f [mm]	Length L [mm]	Width B [mm]
AN 12	11,8	5,0	18,0	13,0
AN 14	13,8	5,0	20,0	14,0
AN 15/16	15,0	5,0	19,5	15,5
AN 18/20	18,5	5,0	24,0	15,5
AN 22/25	22,5	5,0	27,0	15,5
AN 26/28	26,6	5,0	29,0	15,5
AN 30/32	30,5	5,0	34,0	17,0
AN 35/40	34,2	5,0	42,5	18,0
AN 47/50	47,5	5,0	51,0	19,7

Type	Art-No			Pipe-Ø				Recommended distance between clamps [m]	€/100 pcs	[pcs]	[pcs]
	grey	black	white	Metric [mm]	Copper [mm]	Steel [inch]	Plastic [mm]				
AN 12 ¹	912AN	-	-	-	12	-	-	0,50		100	900
AN 14 ¹	914AN	-	-	-	-	1/4"	-	0,50		100	900
AN 15/16	915AN	9415AN	9115AN	16	15	-	16	0,50		100	900
AN 18/20	918AN	9418AN	9118AN	20	18	3/8"	20	0,60		100	900
AN 22/25	922AN	9422AN	9122AN	25	22	1/2"	25	0,75		100	600
AN 26/28	926AN	-	9126AN	-	28	3/4"	-	0,75		100	600
AN 30/32	930AN	9430AN	9130AN	32	32	-	-	0,85		100	-
AN 35/40	935AN	9435AN	-	40	35	1"	40	1,00		100	-
AN 47/50	947AN	-	-	50	-	1-1/2"	50	1,10		50	-

¹ Not to be used in profiles

Advantages Abranyl® ABT



- Recommended for use with gas nailers
- Multidiameter: one clamp size covers three pipe diameters
- Patented clamp



when combining approved accessories, XHA-nails (22-38 mm) and FORCE ONE



ABT

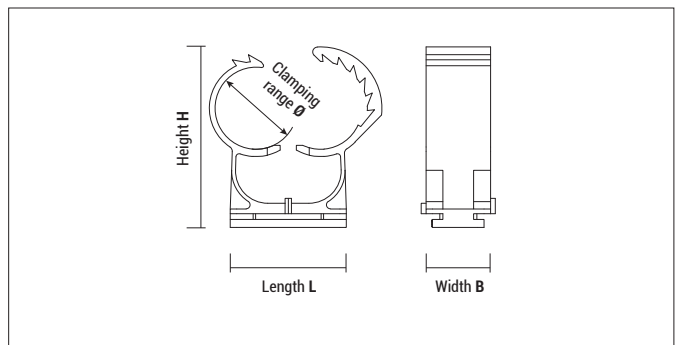

Type	Clamping range Ø [mm]	Length L [mm]	Height H [mm]	Width B [mm]
ABT 14/18	14-18	24,0	35,6	20
ABT 20/25	20-25	29,0	45,5	20
ABT 26/32	26-32	36,0	53,6	20
ABT 35/42	35-42	45,0	66,4	20

Type	Art-No		Art-No		€/100 pcs	Pipe-Ø				ETA	[pcs]	[pcs]
	grey	€/100 pcs	black	white		Metric [mm]	Copper [mm]	Steel [inch]	Plastic [mm]			
ABT 14/18	918ABT		9418ABT	9118ABT		16	14-15-18	3/8"	16	●	100	600
ABT 20/25	925ABT		9425ABT	9125ABT		20-25	22	1/2"	20-25	●	50	450
ABT 26/32	932ABT		9432ABT	9132ABT		32	28	3/4"	32	●	50	300
ABT 35/42	942ABT		9442ABT	9142ABT		40	35-42	1"-1/4"	40-42	●	25	150

Compatible gas nailers can be found on page 249

Plastic clamp Abranyl®

Advantages Abranyl® ABM "Max"



- Multidiameter: one clamp size covers three pipe diameters
- Patented clamp
- Halogen free
- Can be used with screws Ø4.5 mm and plugs Ø6 mm

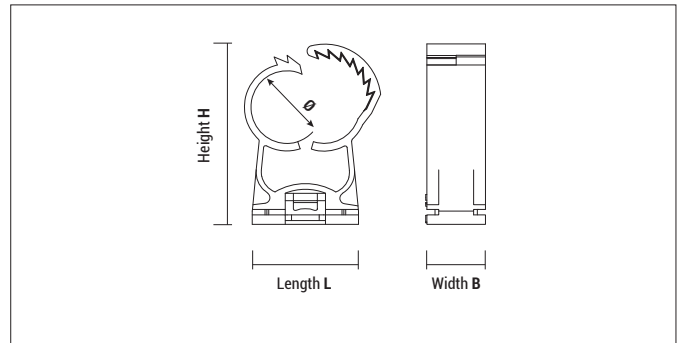

Type	Ø [mm]	Length L [mm]	Height H [mm]	Width B [mm]
ABM 10/14	9,8	22,0	32,0	16,0
ABM 14/18	16,5	20,0	35,0	16,0
ABM 20/25	19,5	29,0	48,0	16,0
ABM 25/32	25,5	32,0	52,0	16,0
ABM 35/42	34,4	45,0	66,0	16,0



ABM "Max"

Type Ø	Art-No			Pipe-Ø				€/100 pcs	[pcs]	[pcs]
	grey	black	white	Metric [mm]	Copper [mm]	Steel [inch]	Plastic [mm]			
ABM 10/14	914ABM	-	-	-	10-12	1/8"-1/4"	-	100	900	
ABM 14/18	918ABM	9418ABM	9118ABM	16	14-15-18	3/8"	16	100	900	
ABM 20/25	925ABM	9425ABM	9125ABM	20-25	22	1/2"	20-25	50	450	
ABM 25/32	932ABM	9432ABM	9132ABM	32	28	3/4"	32	100	-	
ABM 35/42	942ABM	9442ABM	9142ABM	40	35-42	1"-1/4"	40-42	100	-	

Mounting ABM "Max"



Application with Tacomax® Ø6

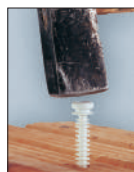

Application with M6-adapter Insertermax®

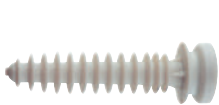
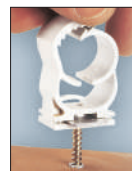

TACOMAX®



INSERMAX®

Accessories for Abranyl® ABM "Max"

Type	Art-No	Size [mm]	€/100 pcs	[pcs]	[pcs]
TACOMAX®	9630TMX	6 x 30		200	1.800
INSERMAX®	96IMX	M6		100	4.000

Multiclip MC



Advantages



- Inner hole 4,5 mm
- Halogen free
- Clamps can be locked into each other
- Marking nib eases alignment



Approvals and certificates

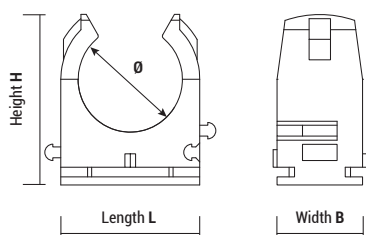

Type	Ø [mm]	Length L [mm]	Height H [mm]	Width B [mm]
MC 16	16	22	27,0	16
MC 18	18	24	29,0	16
MC 20	20	26	31,5	16
MC 22	22	28	34,0	16
MC 25	25	31	35,0	16
MC 32	32	39	43,0	16
MC 40	40	47	51,0	16

MC grey

Type	Art-No	Pipe-Ø		€ / 100 pcs	[pcs]	[pcs]
		Metric [mm]	Copper [mm]			
MC 16	916MC	16	-		100	900
MC 18	918MC	-	18		100	900
MC 20	920MC	20	-		100	900
MC 22	922MC	-	22		100	900
MC 25	925MC	25	-		100	600
MC 32	932MC	32	-		50	450
MC 40	940MC	40	-		50	300

Pipe ring clip UT



Advantages



- Fast installation with gas nailer FORCE ONE & FOX
- Also compatible with gas nailer Powers Trak It® C3, Spit Pulsa 700E/800E
- UT clips can be mounted in series due to lateral slots
- A marking allows quick alignment
- Halogen free
- RoHS compliant

Mounting

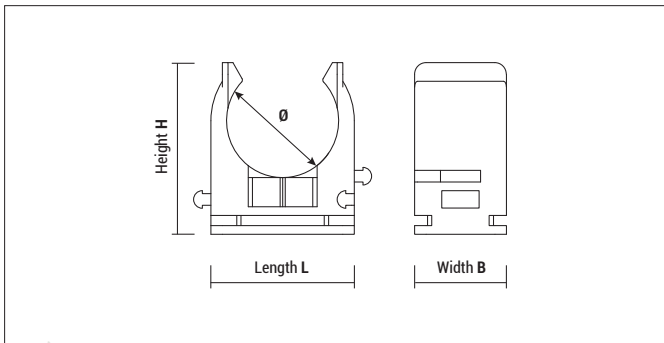

UT

Type	Art-No	Pipe-Ø Plastic [mm]	ETA	€ / 100 pcs	[pcs]	[pcs]
UT 16	916UT	16	●		100	900
UT 20	920UT	20	●		100	900
UT 25	925UT	25	●		100	900
UT 32	932UT	32	●		50	450
UT 40	940UT	40	●		50	300

Approvals and certificates



Type	Ø [mm]	Length L [mm]	Height H [mm]	Width B [mm]
UT 16	15,5	23,0	25,5	16,0
UT 20	19,5	25,0	29,5	16,0
UT 25	24,5	30,5	34,0	16,0
UT 32	31,0	38,0	42,0	16,0
UT 40	39,0	46,0	50,0	16,0

Compatible gas nailers can be found on page 249

Metal clamps

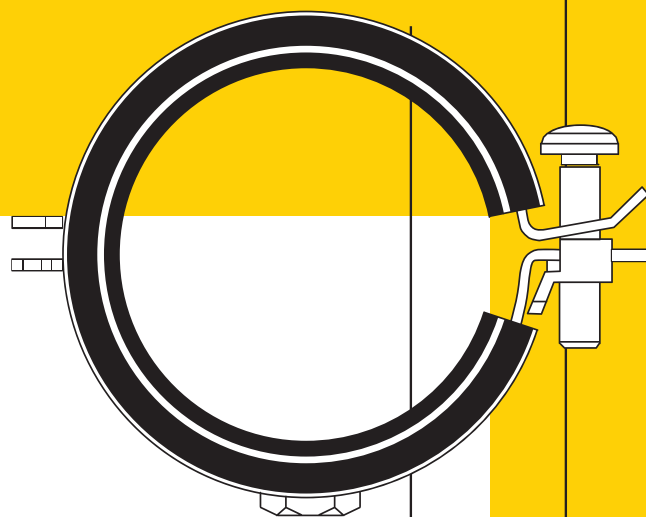

RIF		277
RI		278
RID		280
LI		281
L		282
D		283
SF		284

Overview of metal clamps

[Heavy duty-] Metal clamps



		RIF	RI	RID	LI	L	D	SIN-FIN
Diameter Ø (mm)		15-60	18-355	18-160	12-42	6-63	50-200	10-130
Coating		blue zinc plated	blue zinc plated	blue zinc plated	yellow zinc plated	blue zinc plated	sendzimir zinc plated	blue zinc plated
Inlay		EPDM	EPDM	EPDM+TPE	EPDM	X	X	X
Halogen free		✓	✓	✓	-	-	-	-
RoHS compliant		X	✓	✓	X	X	X	X
Fire resistance		✓ DIN 4102 class B2	✓ DIN 4102 class B2	✓ DIN 4102 class B2	✓ DIN 4102 class B2	✓ DIN 4102 class A1	✓ DIN 4102 class A1	✓ DIN 4102 class A1
Temperature range		-50°C to +110°C	-50°C to +110°C	-50°C to +110°C	-50°C to +110°C	-	-	-
Recommended maximum tension load (kg)		80	80 - 200	100-150	55	50	110	-
Sheet thickness (mm)		1,25	1,5-2,0	1,2-2,0 to +2,5	1,2	1,2	1,25	0,8
Clamp width (mm)		20	20/25	20/25	11/12	11/12	20	9
Connecting thread		M8 + M10	M8 + M10	M8 + M10	M6	M6	M8	X
Applications		Heating pipes, Water pipes	Heating pipes, Water pipes	Sliding EPDM rubber lined pipe clamp for heating pipes or water pipes	Air conditioning, gas or compressed air pipes	Electrical and sanitary	Drainage pipes, PVC pipes, light steel pipes, ventilation pipes	Hose connections
Page		277	278	280	281	282	283	284

Quick clamp RIF



Advantages



- EPDM inlay: (sound-) insulated according to DIN 4109
- Fire behaviour according to DIN 4102, class B2
- Quick installation: 30% less installation time than standard clamps with two screws
- Solid welding of the nut
- Temperature resistance: -50°C to +110 °C, suitable for hot water and heating pipes

Approvals and certificates



Mounting

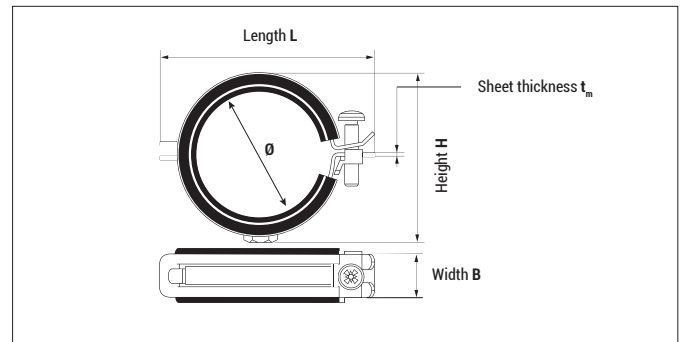
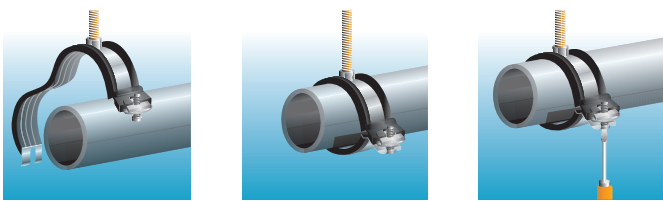

RIF M8 + M10 connecting thread / SW13

Type	Art-No	Pipe-Ø			Inner Ø [mm]	Load* ≤ [kg]	Sheet thickness t _m [mm]	Length L [mm]	Height H [mm]	Clamp width W [mm]	€ / 100 pcs	[pcs]	[pcs]
		Copper [mm]	Steel [inch]	Plastic [mm]									
RIF 15	915RIF	15	1/4"	-	12 - 14	80	1,25	45	46	20		25	225
RIF 18	918RIF	18	3/8"	16	15 - 19	80	1,25	47	48	20		25	225
RIF 22	922RIF	22	1/2"	20	20 - 23	80	1,25	53	54	20		20	180
RIF 28	928RIF	28	3/4"	25	25 - 28	80	1,25	59	60	20		25	225
RIF 35	935RIF	35	1"	32	32 - 35	80	1,25	65	64	20		25	150
RIF 40	940RIF	42	1-1/4"	40	40 - 43	80	1,25	73	72	20		25	150
RIF 48	948RIF	54	1-1/2"	50	48 - 52	80	1,25	80	81	20		20	120
RIF 60	960RIF	-	2"	-	57 - 62	80	1,25	94	95	20		10	90

* Load incl. safety factor

Clamp RI



Advantages



- High strength due to double reinforcing ribs
- Fire behaviour according to DIN 4102, class B2
- Thick EPDM inlay: (sound-) insulated
- Screws are impossible to lose
- Solid welding of the nut
- Nut with M8 and M10 thread for higher flexibility
- Temperature resistance: -50°C to +110 °C, suitable for hot water and heating pipes
- Load capacity tested by an independent institute (Ap-plus+)

Approvals and certificates



Mounting

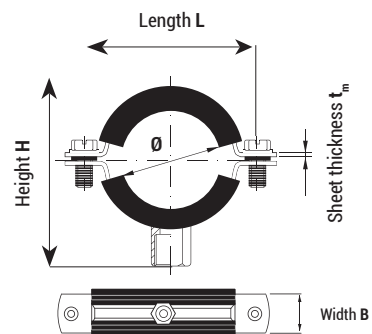

Clamp RI



RI M8 + M10 connecting thread / SW13

Type	Art-No	Pipe-Ø			Inner Ø [mm]	Load* ≤ [kg]	Sheet thickness t _m [mm]	Length L [mm]	Height H [mm]	Clamp width W [mm]	Screw	€ / 100 pcs	[pcs]
		Copper [mm]	Steel [inch]	Plastic [mm]									
RI 18	918RI	18	3/8"	–	15 - 19	80	1,5	60,0	40,5	20	M6x16		100
RI 22	922RI	22	1/2"	–	20 - 24	80	1,5	62,0	45,0	20	M6x16		100
RI 28	928RI	28	3/4"	25	23 - 28	80	1,5	70,5	49,5	20	M6x16		100
RI 35	935RI	35	1"	32	31 - 36	80	1,5	79,0	60,0	20	M6x16		100
RI 40	940RI	42	1 - 1/4"	40	38 - 44	100	1,5	88,0	64,0	20	M6x16		100
RI 48	948RI	–	1 - 1/2"	50	44 - 50	100	1,5	94,0	70,5	20	M6x20		100
RI 54	954RI	54	–	–	54 - 58	100	1,5	102,0	81,5	20	M6x16		50
RI 60	960RI	–	2"	–	59 - 65	100	1,5	109,0	86,5	20	M6x25		50
RI 75	975RI	76	2 - 1/2"	75	74 - 80	150	2,0	133,0	102,5	25	M6x25		50
RI 90	990RI	89	3"	90	83 - 93	150	2,0	145,0	111,5	25	M6x25		50
RI 100	9100RI	–	3 - 1/2"	100	95 - 103	150	2,0	155,0	116,0	25	M6x25		50
RI 110	9110RI	108	4"	110	108 - 118	150	2,0	169,0	122,0	25	M6x25		50
RI 125	9125RI	–	4 - 1/2"	125	121 - 127	150	2,0	128,8	135,5	25	M6x30		50
RI 140	9140RI	–	5"	140	133 - 143	150	2,0	198,5	145,5	25	M6x25		50
RI 160	9160RI	–	6"	160	159 - 169	150	2,0	229,0	161,5	25	M6x25		40
RI 200	9200RI	–	–	200	198 - 202	150	2,0	262,0	184,5	25	M6x25		40
RI 250	9250RI	–	–	250	249 - 254	200	2,0	290,0	275,0	25	M6x25		30
RI 355 ¹⁾	9355RI	–	–	355	354 - 359	200	2,3	396,0	381,0	20	M6x25		20

* Load incl. safety factor

¹⁾ discontinued article; delivery while stocks last

RI clamp set

Type	Art-No	Plug-Ø [mm]	Plug length [mm]	Load* ≤ [kg]	Set contains	€ / Blister	[pcs]	[Blister]
FX 10 RI 22	22RIEDRN	10	50	80	FX 10 + M8x80 + RI 22		2	15
FX 10 RI 28	28RIEDRN	10	50	80	FX 10 + M8x80 + RI 28		2	15
FX 10 RI 35	35RIEDRN	10	50	80	FX 10 + M8x80 + RI 35		2	15
FX 10 RI 40	40RIEDRN	10	50	100	FX 10 + M8x80 + RI 40		2	15
FX 10 RI 50	50RIEDRN	10	50	100	FX 10 + M8x80 + RI 50		2	15
FX 10 RI 60	60RIEDRN	10	50	100	FX 10 + M8x80 + RI 60		2	15
FX 10 RI 75	75RIEDRN	10	50	150	FX 10 + M8x80 + RI 75		2	15
FX 12 RI 90	90RIEDRN	12	60	150	FX 12 + M10x100 + RI 90		2	15
FX 12 RI 110	110RIEDRN	12	60	150	FX 12 + M10x100 + RI 110		2	15

* Load incl. safety factor

Sliding pipe clamp

RID

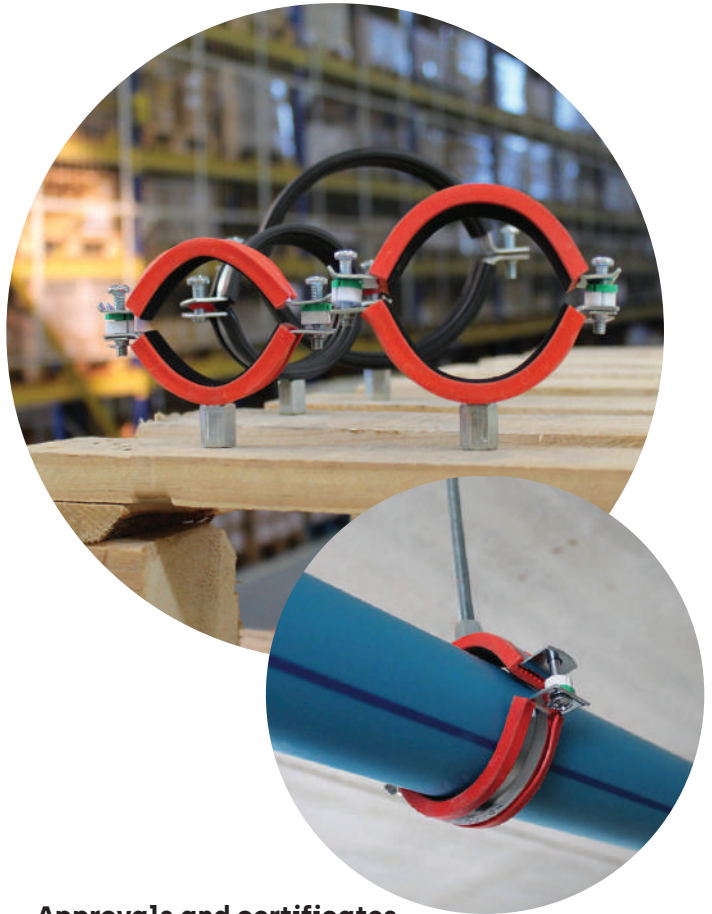

Advantages



- TPE rubber inlay with soft inner side allows the pipe to slide
- Fire behaviour according to DIN 4102, class B2
- Easy and fast mounting thanks to the side opening
- Plastic washers, which allow installation as fixed or sliding points
- Suitable for plastic pipes
- Clamp with double reinforcing ribs for greater stability
- Soundproof according to DIN 4109
- Connecting thread M8 + M10
- Temperature resistant EPDM rubber from -50°C to +110°C
- UV- and seawater resistant

Approvals and certificates



Mounting

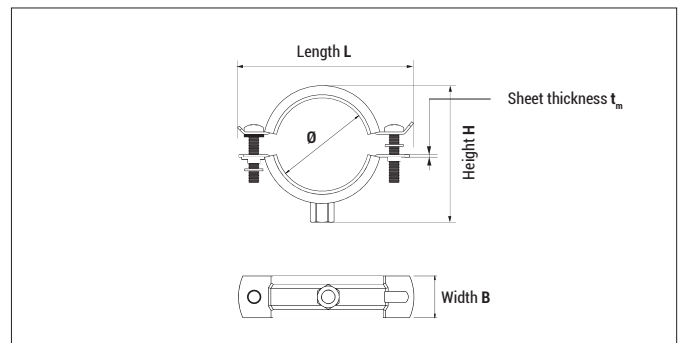

RID M8 + M10 connecting thread / SW13

Type	Art-No	Pipe-Ø			Inner Ø [mm]	Load* ≤ [kg]	Sheet thickness t _m [mm]	Length L [mm]	Height H [mm]	Clamp width W [mm]	Screw	€/ 100 pcs	[pcs]
		PPP [mm]	CPVC [mm]	CPVC [inch]									
RID 18	918RID	16	15,9	1/2"	15-19	100	1,2	58	42	20	M6x20		100
RID 22	922RID	20	22,2	3/4"	20-23	100	1,2	62	44	20	M6x20		100
RID 28	928RID	25	28,6	1	26-30	100	1,2	69	51	20	M6x20		100
RID 35	935RID	32	34,9	1 1/4"	31-36	100	1,2	74	56	20	M6x25		100
RID 42	942RID	40	41,3	1 1/2"	40-46	100	1,2	84	65	20	M6x20		100
RID 48	948RID	50	54,0	2"	48-53	100	1,2	94	72	20	M6x20		50
RID 54	954RID	54	-	-	54-59	100	1,2	105	80	20	M6x20		50
RID 60	960RID	60	60,3	2"	60-64	150	1,2	110	88	20	M6x25		50
RID 75	975RID	75	73,0	2 1/2"	72-83	150	2	135	104	25	M6x25		50
RID 90	990RID	90	88,9	3	87-92	150	2	145	120	25	M6x25		50
RID 110	9110RID	110	114,0	4	102-116	150	2	157	126	25	M6x25		50
RID 125	9125RID	125	-	-	124-130	150	2	157	132	25	M6x30		50
RID 160	9160RID	160	168	6	159-168	150	2	195	162	25	M6x30		25

* Load incl. safety factor

Metal clamp

LI



Advantages



- EPDM inlay: (sound-) insulated
- Fire behaviour according to DIN 4102, class B2
- Easy to use
- Quick installation
- Connection thread: M6
- Strong design
- Temperature resistance: -30°C to +100 °C, suitable for hot water and heating pipes



Approvals and certificates



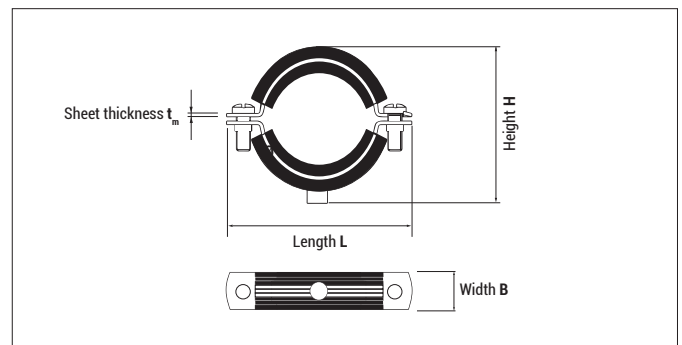

see assessment

Mounting



LI, yellow galvanized M6 connecting thread

Type	Art-No	Pipe-Ø				Load* ≤ [kg]	Sheet thickness t _m [mm]	Length L [mm]	Height H [mm]	Clamp width W [mm]	€/ 100 pcs	 [pcs]	 [pcs]
		Metric [mm]	Copper [mm]	Steel [inch]	Plastic [mm]								
LI 12	9B12LI	-	12	-	-	55	1,2	41	23,5	11/12	100	900	
LI 15	9B15LI	-	15	1/4"	-	55	1,2	43	25,0	11/12	100	900	
LI 18	9B18LI	-	18	3/8"	-	55	1,2	47	29,0	11/12	100	900	
LI 22	9B22LI	-	22	1/2"	-	55	1,2	51	33,0	11/12	50	450	
LI 28	9B28LI	-	28	-	-	55	1,2	57	39,0	11/12	50	450	
LI 35	9B35LI	-	35	1	-	55	1,2	66	47,0	11/12	25	225	
LI 42	9B42LI	-	42	1 1/4	42	55	1,2	70	51,5	11/12	25	225	

* Load incl. safety factor

Metal clamp

Advantages



- Easy and quick installation
- Fire behaviour according to DIN 4102, class A1
- With reinforcing ribs
- Connection thread: M6

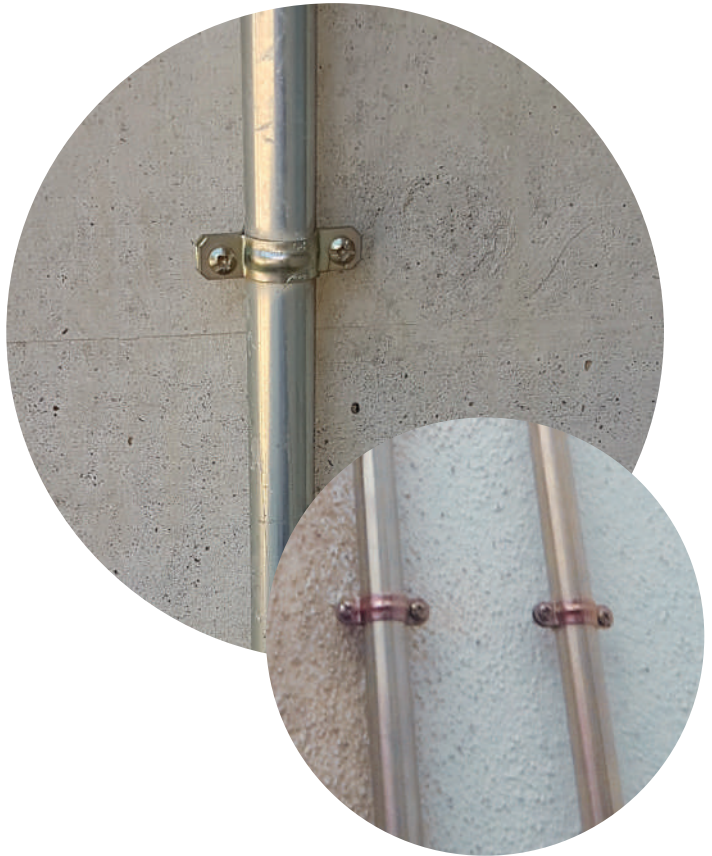

Mounting

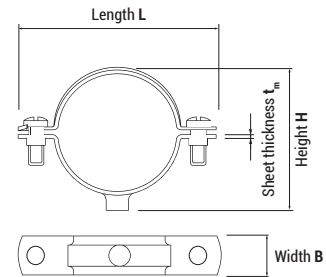

Approvals and certificates



see assessment



L M6, M6 connecting thread

Type	Art-No	Pipe-Ø				Load* ≤ [Kg]	Sheet thickness t _m [mm]	Length L [mm]	Height H [mm]	Clamp width W [mm]	€/100 pcs	[pcs]	[pcs]
		Metric [mm]	Copper [mm]	Steel [inch]	Plastic [mm]								
L 6	96L	-	6	-	-	50	1,2	31	13,7	11/12		100	1.800
L 8	98L	-	8	-	-	50	1,2	33	15,5	11/12		100	1.800
L 10	910L	-	10	1/8"	-	50	1,2	35	17,7	11/12		100	1.800
L 12	912L	-	12	-	-	50	1,2	37	19,7	11/12		100	900
L 14	914L	-	-	1/4"	-	50	1,2	39	21,7	11/12		100	900
L 16	916L	16	-	-	16	50	1,2	41	23,7	11/12		100	900
L 20	920L	20	-	-	20	50	1,2	45	27,2	11/12		100	900
L 25	925L	25	-	-	25	50	1,2	51	32,2	11/12		100	900
L 26	926L	-	-	3/4"	-	50	1,2	52	33,2	11/12		100	900
L 32	932L	32	-	-	32	50	12,	57	39,2	11/12		50	450
L 40	940L	40	-	-	40	50	1,2	66	47,2	11/12		50	450
L 50	950L	50	-	-	50	50	1,2	78	56,7	12/14		25	225
L 60	960L	-	-	2"	60	50	1,2	88	66,7	12/14		25	225
L 63	963L	63	63	-	63	50	1,2	90	69,7	12/14		25	225

* Load incl. safety factor

Heavy-duty metal drainage clamp

D

Advantages



- Connecting thread: M8
- Fire behaviour according to DIN 4102, class A1
- Sendzimir galvanized
- No damage of the pipe at the connection thread due to the special design of the clamp
- Captive screws and nuts

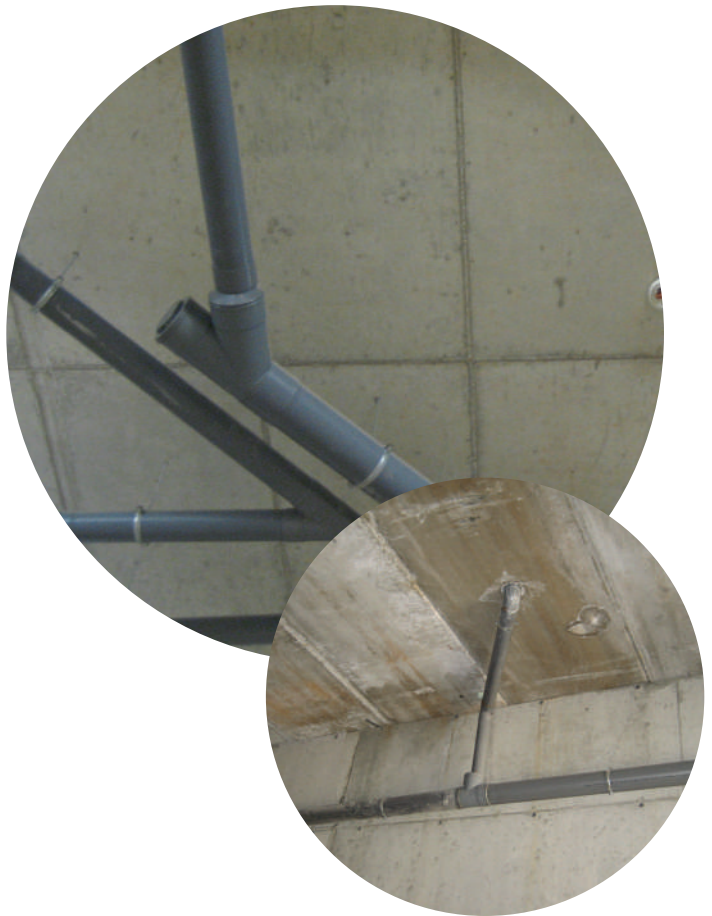

Mounting

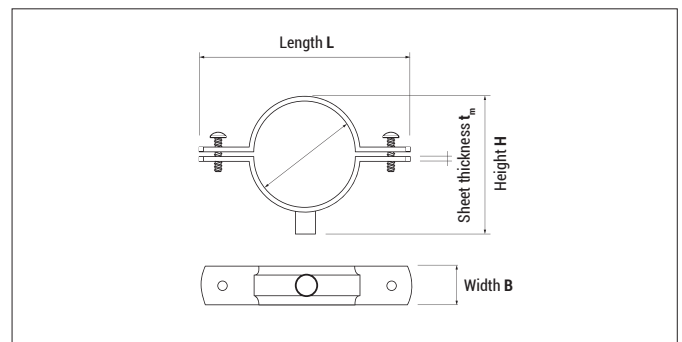

D, sendzimir galvanized M8 connecting thread

Type	Art-No	Pipe-Ø [mm]	Load ¹⁾ ≤ [kg]	Sheet thickness t_m [mm]	Length L [mm]	Height H [mm]	Width W [mm]	€/100 pcs	 [pcs]
D 50	950D	50	110	0,8	106	67	28		50
D 60	960D	60	110	0,8	116	77	28		50
D 75	975D	75	110	0,8	131	92	28		50
D 80	980D	80	110	0,8	136	97	28		50
D 90	990D	90	110	0,8	146	107	28		50
D 100	9100D	100	110	0,8	156	117	28		50
D 110	9110D	110	110	0,8	166	127	28		50
D 125	9125D	125	110	0,8	181	142	28		50
D 150	9150D	150	110	0,8	206	167	28		50
D 160	9160D	160	110	1,0	216	177	28		50
D 200	9200D	200	110	1,0	256	217	28		50

Load incl. safety factor

Hose clamp SF



Advantages



- Worm drive clamp for fast and easy tightening around the hose
- Fire behaviour according to DIN 4102, class A1
- Rounded edges to avoid damaging the hose or tube

SF, zinc plated

Type	Art-No	Pipe-Ø [mm]	Sheet thickness [mm]	Width [mm]	Torque [kg-cm]	€ / 100 pcs	 [pcs]	 [pcs]
SF 10/16	910SF	10-16	0,8	9	2,5		100	900
SF 12/20	912SF	12-20	0,8	9	2,5		100	900
SF 15/25	915SF	15-25	0,8	9	2,5		100	900
SF 20/32	920SF	20-32	0,8	9	3,0		100	900
SF 25/40	925SF	25-40	0,8	9	3,0		100	600
SF 32/50	932SF	32-50	0,8	9	3,0		100	600
SF 40/60	940SF	40-60	0,8	9	3,0		100	–
SF 50/70	950SF	50-70	0,8	9	3,0		50	300
SF 90/110	990SF	90-110	0,8	9	3,0		25	–
SF 100/120	9100SF	100-120	0,8	9	3,0		25	–
SF 130	9130SF	130	0,8	9	3,0		25	–

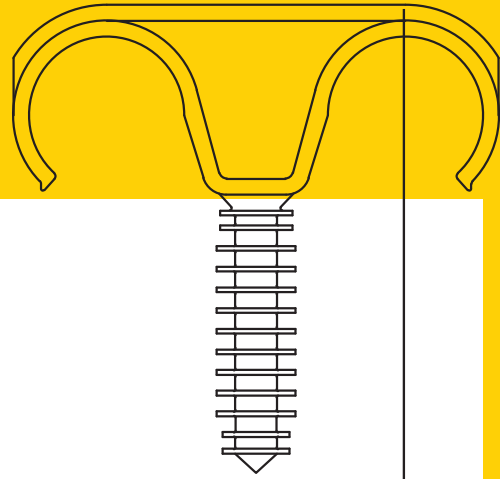

Electrical Fixings

CCT		286
InsertFIX		288
FTD / FTS		290
TACCABLE®		291
Plastigrap®		292
F & DF		293
CH		295
CA		296

Cable tie CCT

Advantages



- Cable tie tapered and rounded for easy insertion
- Robust design, first-class quality
- Suitable for indoor and outdoor use
- Black: UV-resistant
- Halogen free
- RoHS compliant
- Installation temperature: -10°C to +45°C
- Temperature resistance: -40°C to +85°C
- Can be used together with push-in plug InsertFIX and cable tie fasteners TBB, TBL, TBD, TBM

Approvals and certificates



- Packed in a practical bag with EURO punching
- Transparent bag for optimal product presentation

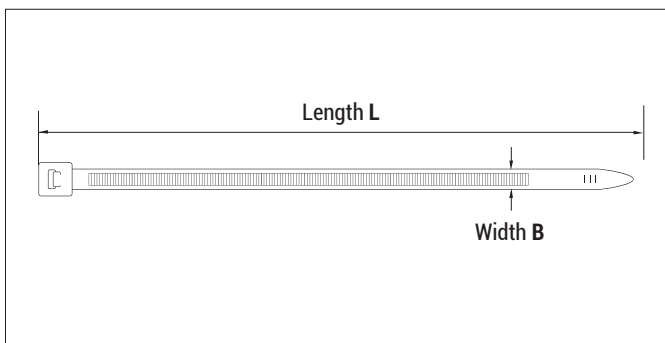



Recommended loads F_{rec}

Type	Load \leq [kg]
2,5	8
3,6	18
4,8	22
7,6	55
8,8	80
9,0	80
12,6	110

Cable tie CCT







Cable tie CCT natural coloured

Type	Art-No	Width	Length	∅	€/100pcs				Min. sales unit
	natural	W [mm]	L [mm]	≤ [mm]					
CCT 2,5x100	125100CCT	2,5	100	20,5		100	1.000	50.000	1.000
CCT 2,5x150	125150CCT	2,5	150	39,8		100	1.000	25.000	1.000
CCT 2,5x200	125200CCT	2,5	200	52,5		100	1.000	25.000	1.000
CCT 3,6x140	136140CCT	3,6	140	33,0		100	1.000	25.000	1.000
CCT 3,6x200	136200CCT	3,6	200	52,5		100	1.000	20.000	1.000
CCT 3,6x300	136300CCT	3,6	300	84,0		100	1.000	10.000	1.000
CCT 3,6x370	136370CCT	3,6	370	106,0		100	1.000	10.000	1.000
CCT 4,8x200	148200CCT	4,8	200	49,5		100	1.000	10.000	1.000
CCT 4,8x250	148250CCT	4,8	250	65,0		100	1.000	10.000	1.000
CCT 4,8x300	148300CCT	4,8	300	81,0		100	1.000	10.000	1.000
CCT 4,8x370	148370CCT	4,8	370	103,5		100	1.000	5.000	1.000
CCT 4,8x430	148430CCT	4,8	430	122,5		100	1.000	5.000	1.000
CCT 7,6x150	176150CCT	7,6	150	35,0		100	1.000	5.000	100
CCT 7,6x200	176200CCT	7,6	200	50,9		100	1.000	5.000	100
CCT 7,6x300	176300CCT	7,6	300	82,8		100	1.000	5.000	100
CCT 7,6x365	176365CCT	7,6	365	105,0		100	1.000	5.000	100
CCT 7,6x450	176450CCT	7,6	450	130,5		100	1.000	5.000	100
CCT 7,6x550	176550CCT	7,6	550	159,0		100	1.000	2.000	100
CCT 8,8x760	188760CCT	8,8	760	229,5		50	500	1.000	50
CCT 9,0x810	190810CCT	9,0	810	245,0		50	500	1.000	50
CCT 12,6x530	1126530CCT	12,6	530	156,0		50	500	1.250	50
CCT 12,6x1030	11261030CCT	12,6	1.030	315,0		50	500	1.250	50

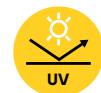

Cable tie CCT black



Type	Art-No	Width B	Length L	∅ ≤	€/100 pcs				Min. sales unit
	black	[mm]	[mm]	[mm]					
CCT 2,5x100	425100CCT	2,5	100	20,5		100	1.000	50.000	1.000
CCT 2,5x150	425150CCT	2,5	150	39,8		100	1.000	25.000	1.000
CCT 2,5x200	425200CCT	2,5	200	52,5		100	1.000	25.000	1.000
CCT 3,6x140	436140CCT	3,6	140	33,0		100	1.000	25.000	1.000
CCT 3,6x200	436200CCT	3,6	200	52,5		100	1.000	20.000	1.000
CCT 3,6x300	436300CCT	3,6	300	84,0		100	1.000	10.000	1.000
CCT 3,6x370	436370CCT	3,6	370	106,0		100	1.000	10.000	1.000
CCT 4,8x200	448200CCT	4,8	200	49,5		100	1.000	10.000	1.000
CCT 4,8x250	448250CCT	4,8	250	65,0		100	1.000	10.000	1.000
CCT 4,8x300	448300CCT	4,8	300	81,0		100	1.000	10.000	1.000
CCT 4,8x370	448370CCT	4,8	370	103,5		100	1.000	5.000	1.000
CCT 4,8x430	448430CCT	4,8	430	122,5		100	1.000	5.000	1.000
CCT 7,6x150	476150CCT	7,6	150	35,0		100	1.000	5.000	100
CCT 7,6x200	476200CCT	7,6	200	50,9		100	1.000	5.000	100
CCT 7,6x300	476300CCT	7,6	300	82,8		100	1.000	5.000	100
CCT 7,6x365	476365CCT	7,6	365	105,0		100	1.000	5.000	100
CCT 7,6x450	476450CCT	7,6	450	130,5		100	1.000	5.000	100
CCT 7,6x550	476550CCT	7,6	550	159,0		100	1.000	2.000	100
CCT 8,8x760	488760CCT	8,8	760	229,5		50	500	1.000	50
CCT 9,0x810	490810CCT	9,0	810	245,0		50	500	1.000	50
CCT 12,6x530	4126530CCT	12,6	530	156,0		50	500	1.250	50
CCT 12,6x1030	41261030CCT	12,6	1.030	315,0		50	500	1.250	50

Push-in plug InsertFIX



Advantages



InsertFIX IFS, small head



InsertFIX IFB, big head

- Very fast installation system. Just drill a hole \varnothing 6 mm and push the plug into the drill hole by hand
- The InsertFIX can be used in almost all base materials
- Due to the special barbs a simple installation is possible with high pull-out loads at the same time
- Made out of age-resistant nylon
- The notch in the head hole prevents slipping of the cable tie

Approvals and certificates



Suitable building materials

Very suitable



- Concrete
- Natural stone
- Solid brick
- Solid sand-lime brick
- Lightweight solid concrete blocks
- Aerated concrete
- Hollow brick
- Hollow sand-lime brick

Mounting

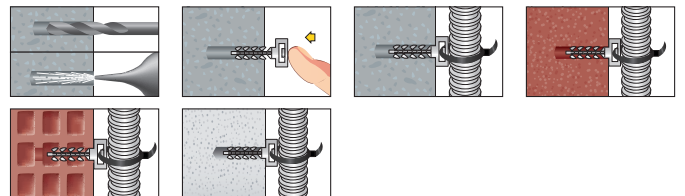

Push-in plug InsertFIX

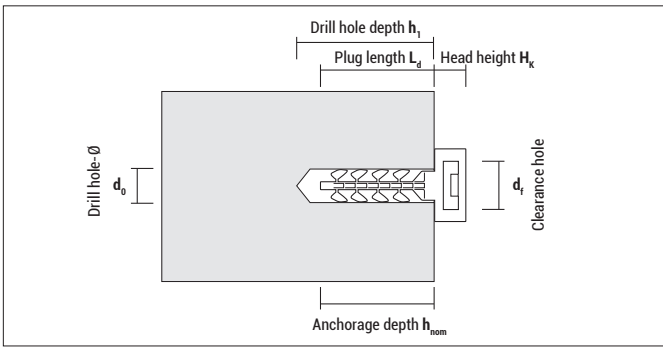

InsertFIX IFS with small head

Type	Art-No	Colour	d_0 [mm]	L_d [mm]	$h_1 \geq$ [mm]	h_{nom} [mm]	H_k [mm]	d_t [mm]	€ / 100 pcs	[pcs]	[pcs]
IFS 6 grey	96IFS	grey	6	31	30	25	6	5,5		100	4.800
IFS 6 black	946IFS	black	6	31	30	25	6	5,5		100	4.800



InsertFIX IFB with big head

Type	Art-No	Colour	d_0 [mm]	L_d [mm]	$h_1 \geq$ [mm]	h_{nom} [mm]	H_k [mm]	d_t [mm]	€ / 100 pcs	[pcs]	[pcs]
IFB 6 grey	96IFB	grey	6	31	30	25	6	10		100	2.700
IFB 6 black	946IFB	black	6	31	30	25	6	10		100	2.700

Loads and dimensions F_{rec}

Type	Concrete 20/25 F_{rec} [kN]	Solid sand-lime brick F_{rec} [kN]	Hollow brick HLz 12 F_{rec} [kN]	Lightweight hollow concrete blocks F_{rec} [kN]
IFS / IFB	0,08	0,08	0,08	0,08

F_{rec} : Recommended load in all directions incl. safety factor of 5

Push clip TACLIP® FTD & FTS



Advantages

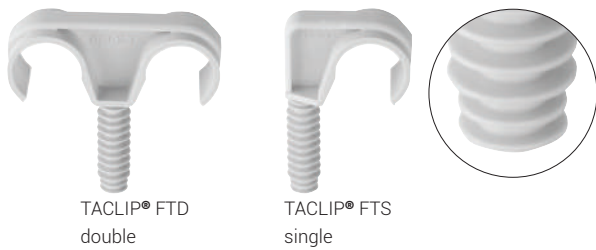

- Multidiameter, each clip fixes 3 pipe diameters
- Quick installation, good grip
- Halogen-free
- Self-centering



Mounting

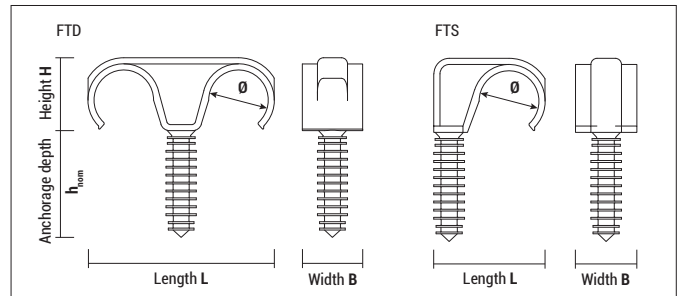
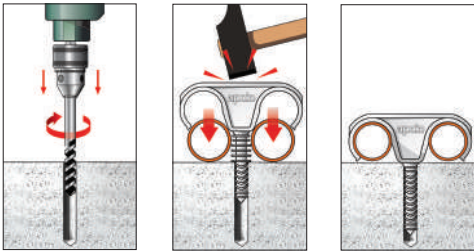

Type	Ø [mm]	h _{nom} [mm]	Length L [mm]	Height H [mm]	Width B [mm]
FTD/FTS 18	16	35	51/30	20	20
FTD/FTS 22	20	35	62/36,5	24	20
FTD/FTS 28	25	35	73/43,5	29	20



TACLIP® FTD double made of nylon, self-centering

Type	Art-No	Drill hole Ø [mm]	Pipe-Ø			Pipe-Ø [mm]	€/ 100 pcs	[pcs]	[pcs]
			Metric [mm]	Steel [inch]	Copper [mm]				
FTD 18	918FTD	8	16	3/8"	18	16 - 19		50	450
FTD 22	922FTD	8	20	1/2"	22	20 - 23		50	300
FTD 28	928FTD	8	25	3/4"	28	25 - 29		50	-



TACLIP® FTS single made of nylon, self-centering

Type	Art-No	Drill hole Ø [mm]	Pipe-Ø			Pipe-Ø [mm]	€/ 100 pcs	[pcs]	[pcs]
			Metric [mm]	Steel [inch]	Copper [mm]				
FTS 18	918FTS	8	16	3/8"	18	16 - 19		100	900
FTS 22	922FTS	8	20	1/2"	22	20 - 23		100	600
FTS 28	928FTS	8	25	3/4"	28	25 - 29		50	450

Push loop TACCABLE®

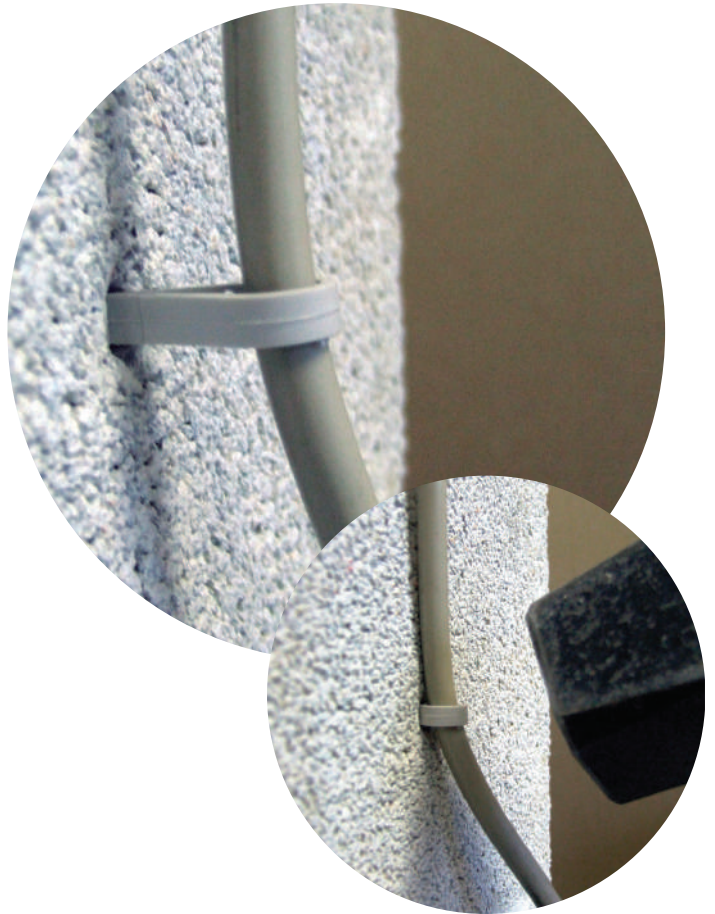

Advantages



- Large clamping range for diameters 3-28 mm for cables or conduits
- Small drill diameter of 6 mm
- Maximum pull-out load in concrete approx. 30 kg

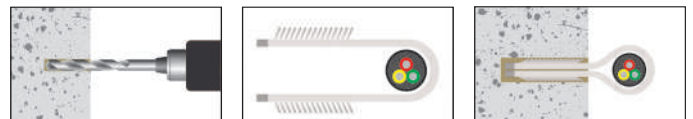

Mounting

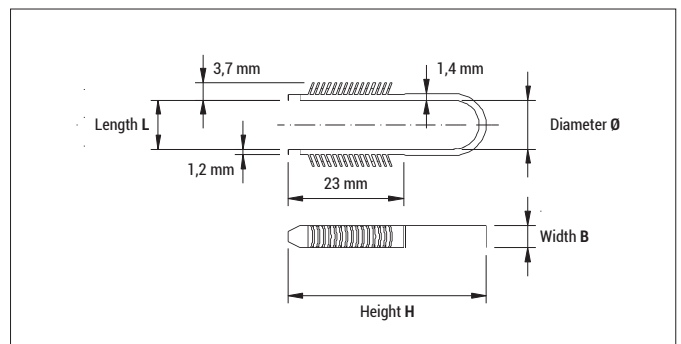

Approvals and certificates



TACCABLE®

Type	Art-No	Drill hole Ø [mm]	H [mm]	L [mm]	B [mm]	Pipe-Ø / Cable-Ø [mm]	€ / 100 pcs	 [pcs]	 [pcs]
TCB 3x13	913TCB	6	39,4	10,4	4,8	3 - 13		200	3.600
TCB 13-28	928TCB	6	59,4	10,4	4,8	13 - 28		100	900

Cable clip Plastigrap®



Advantages



5 bags
per 100 pcs



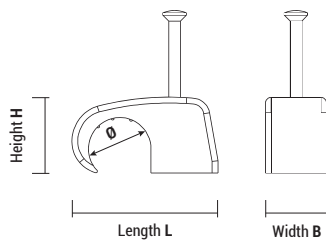

- Hardened nails, usable for bricks and natural stone

Mounting



Type	Ø [mm]	Length L [mm]	Height H [mm]	Width B [mm]
RB 4 / RN 4	4	10,5	6,5	6,5
RB 5 / RN 5	5	11,0	7,5	6,5
RB 6 / RN 6	6	13,0	9,0	6,5
RB 7 / RN 7	7	13,5	10,0	6,5
RB 8 / RN 8	8	14,0	10,5	6,5
RB 9 / RN 9	9	16,5	13,0	7,0
RB 10 / RN 10	10	19,0	15,0	9,0

Plastigrap®

Colour	Type	Art-No	Cable-Ø	€/ 100 pcs	 [pcs]	 [pcs]
 white	RB 4	14PLG	4		500	9.000
	RB 5	15PLG	5		500	9.000
	RB 6	16PLG	6		500	4.500
	RB 7	17PLG	7		500	4.500
	RB 8	18PLG	8		500	4.500
	RB 9	19PLG	9		500	4.500
	RB 10	110PLG	10		500	4.500
 black	RN 6	46PLG	6		500	4.500
	RN 7	47PLG	7		500	4.500
	RN 8	48PLG	8		500	4.500
	RN 9	49PLG	9		500	4.500
	RN 10	410PLG	10		500	4.500

Metal clip with hole

F & DF

Advantages



- Two ribs for increased stability
- Hole \varnothing 6,5 mm for assembly with plugs
- Zinc plate coated
- Can be mounted with all common plugs, nail plug NP, concrete screw BTS 4, BTS 5, ceiling anchor DA etc.



Approvals and certificates



see assessment

Mounting

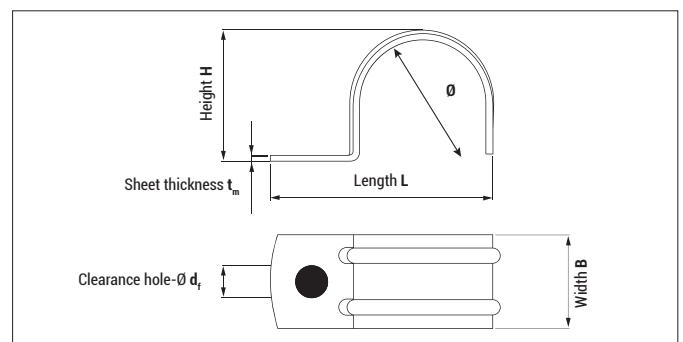

Metal clip with hole F & DF



F clip

Type	Art-No	Diameter Ø [mm]	Length L [mm]	Width B [mm]	Height H [mm]	Clearance hole Ø d _f [mm]	Sheet thick- ness t _m [mm]	€ / 100 pcs	[pcs]	[pcs]
F Clip 6	96F	6	21,8	12	7,4	6,5	0,8		100	4.000
F Clip 8	98F	8	23,8	12	9,4	6,5	0,8		100	4.000
F Clip 10	910F	10	25,8	12	11,4	6,5	0,8		100	1.800
F Clip 12	912F	12	27,8	12	13,4	6,5	0,8		100	1.800
F Clip 14	914F	14	31,5	15	15,6	6,5	1		100	1.800
F Clip 16	916F	16	33,5	15	17,6	6,5	1		100	1.800
F Clip 18	918F	18	35,5	15	19,6	6,5	1		100	900
F Clip 20	920F	20	38,7	18	21,9	6,5	1,2		100	900
F Clip 22	922F	22	40,7	18	23,9	6,5	1,2		100	900
F Clip 25	925F	25	43,7	18	26,9	6,5	1,2		100	900
F Clip 28	928F	28	46,7	18	29,9	6,5	1,2		100	900
F Clip 32	932F	32	53,5	20	34,3	6,5	1,5		100	600
F Clip 40	940F	40	61,5	20	42,3	6,5	1,5		100	450
F Clip 50	950F	50	71,5	20	52,3	6,5	1,5		100	450



DF Clip

Type	Art-No	Diameter Ø [mm]	Length L [mm]	Width B [mm]	Height H [mm]	Clearance hole Ø d _f [mm]	Sheet thick- ness t _m [mm]	€ / 100 pcs	[pcs]	[pcs]
DF Clip 6	96DF	6	38,5	12	5	6,5	1		100	1.800
DF Clip 8	98DF	8	42,5	12	7	6,5	1		100	1.800
DF Clip 10	910DF	10	46,0	12	9	6,5	1		100	900
DF Clip 12	912DF	12	51,0	12	11	6,5	1		100	900

Technical information F-Clip

Ø [mm]	recom. Loads [kg]	pipe-Ø		
		Plastic [mm]	Copper [mm]	Steel [Inch]
F Clip 6	12	-	6	-
F Clip 8	12	-	8	-
F Clip 10	12	-	10	1/8"
F Clip 12	12	-	12	-
F Clip 14	15	-	-	1/4"
F Clip 16	15	16	-	-
F Clip 18	15	-	18	3/8"
F Clip 20	18	20	-	-
F Clip 22	18	-	22	1/2"
F Clip 25	18	25	-	-
F Clip 28	18	-	28	-
F Clip 32	20	32	-	-
F Clip 40	20	40	-	-
F Clip 50	20	50	-	-

Technical information DF-Clip

Ø [mm]	recom. Loads [kg]	pipe-Ø		
		Plastic [mm]	Copper [mm]	Steel [Inch]
DF Clip 6	7	-	6	-
DF Clip 8	7	-	8	-
DF Clip 10	7	-	10	1/8"
DF Clip 12	7	-	12	-

Metal clamp for electrical cables

CH

Advantages



- Quick fixing of cable bundles
- Possibility to install different cable diameters at the same time
- Collective bracket for quick installation with BTS6 concrete screw
- Two mounting positions: on ceiling and wall
- Easy extension of cables

Approvals and certificates



see assessment

CH

Type	Art-No	Length L [mm]	Width B [mm]	Height H [mm]	d _{r1} [mm]	d _{r2} [mm]	Cable capacity			€ / 100 pcs	[pcs]	[pcs]
							Ø6	Ø8	Ø10			
CH 63x40x32	94055CH	33,5	32	57	7	12	25	19	12		100	
CH 85x55x32	95580CH	49	32	79	7	12	50	38	25		50	

Recommended loads F_{rec} (kN)

Distance between clamps [mm]	300	400	500	600	700	800
Maximum recommended load per clamp (kg)	≤ 6 ¹⁾	≤ 4,5	≤ 3,6	≤ 3	≤ 2,6	≤ 2,3

¹⁾ The maximum load capacity is 6 kg/m.

It is recommended to install with a spacing of 300 mm to 600 mm, depending on the stiffness of the cable.

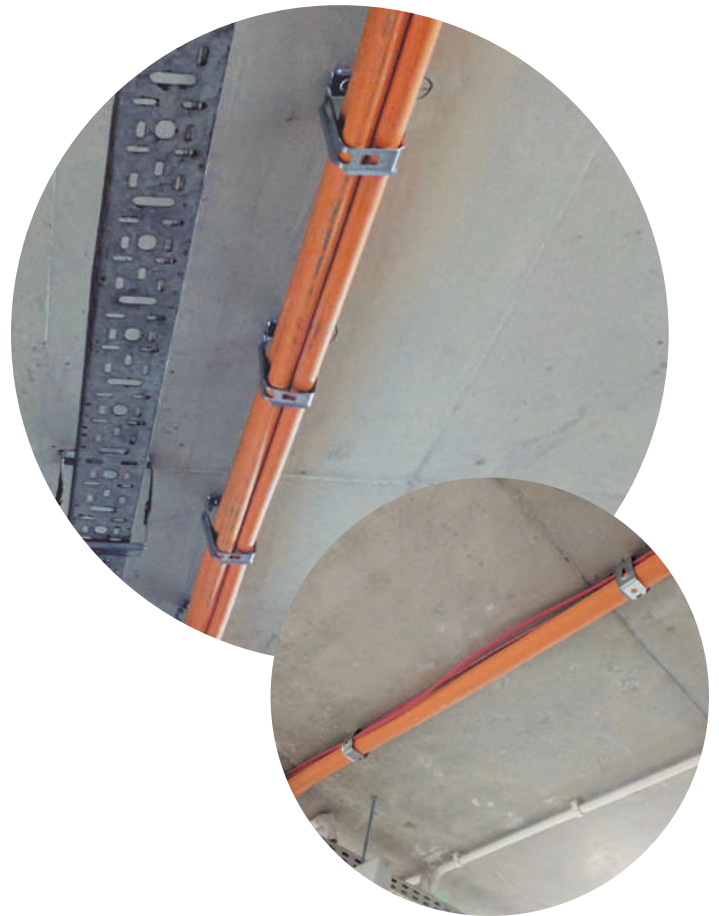

Mounting

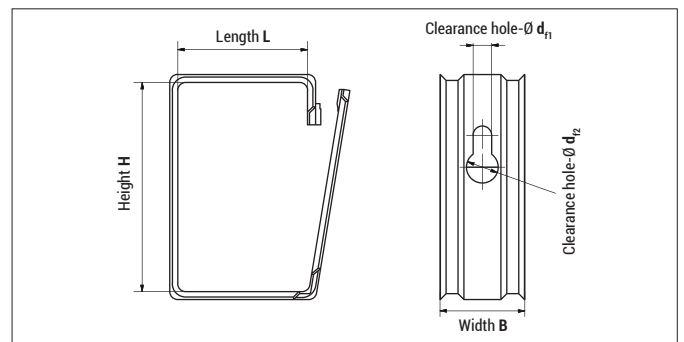

Punched metal tape

CA



Advantages



- Made of soft steel for eased bending
- Can also be used in combination with gas nailer FORCE ONE and FOX

Mounting

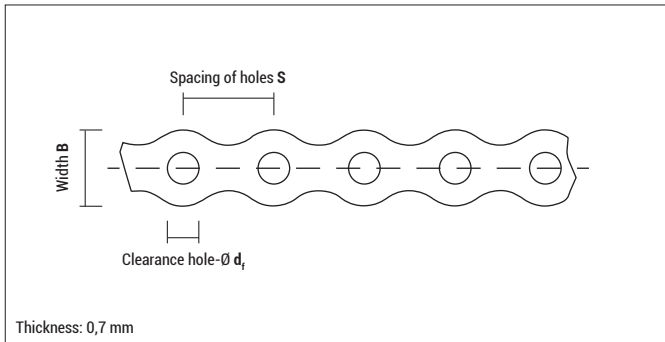



Approvals and certificates



see assessment

Cintapolo, sendzimirzinc plated 10 m per roll

Type	Art-No	Width B [mm]	Clearance hole-Ø d _f [mm]	Spacing of holes S [mm]	Tension strength ≤ [kg]	€/ pcs	 [pcs]	 [pcs]
Cintapolo 12	12CA	12	5,1	14	50		10	-
Cintapolo 17	CA	17	7	20	95		10	-

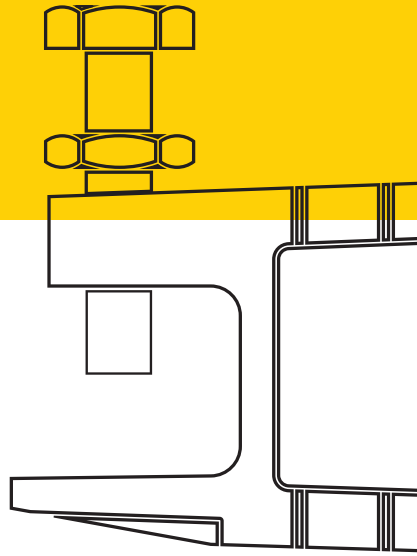

Beam fixings

CAL		298
CBR		300
CC		301
CVA		303
CAB		305
CMV		307
PMV		308

Hammer-on flange beam clip **CAL**



Advantages



CAL,
spring steel, zinc flake coated

- Fast and stable fixing system to metal beams
- No drilling or welding required as the clamp is simply hammered onto the flange
- 6,3 mm hole to insert wires, cable ties, S- shape hooks, bolts or chains
- Zinc flake coating for indoor, limited outdoor, humid and corrosive environments, resistant to corrosion in salt water mist for up to 480 hours (DIN 50021)

Suitable building materials

Very suitable



- Steel beams

Approvals and certificates



see assessment

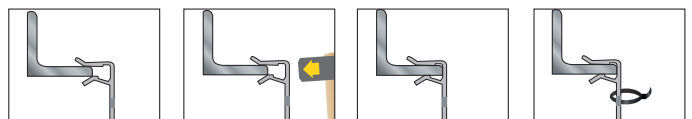
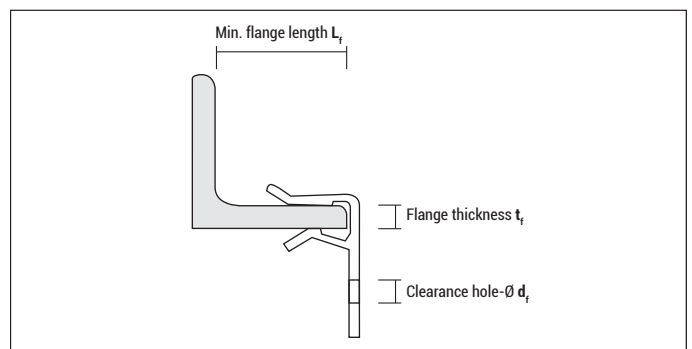

Mounting

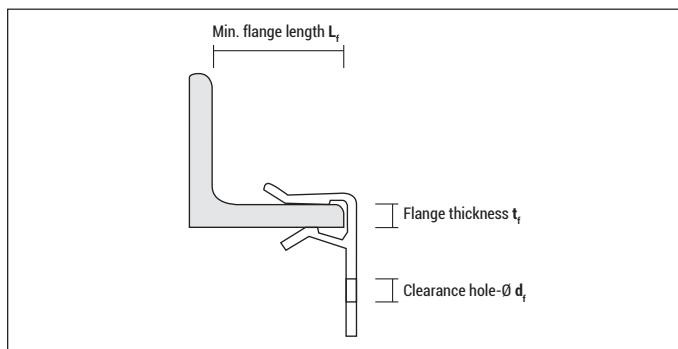

Hammer-on flange beam clip CAL



CAL, zinc flake coating

Type	Art-No	$L_f \geq$ [mm]	t_f [mm]	d_f [mm]	€ / pcs	 [pcs]	 [pcs]
CAL 1,5-4	915463CAL	18	1,5 - 4	6,3		100	1.800
CAL 4,0-10	941063CAL	25	4 - 10	6,3		100	600
CAL 10-15	9101563CAL	25	10 - 15	6,3		100	600
CAL 15-20	9152063CAL	25	15 - 20	6,3		100	600

Loads and installation parameters

Type	Recommended loads [kN]
CAL 1,5-4	0,7
CAL 4,0-10	0,9
CAL 10-15	0,9
CAL 15-20	0,9

Recommended load with safety factor ($\mu = 3$) under vertical tensile load

Hammer-on flange beam clip CBR



Advantages



CBR, spring steel, zinc flake coated

- To install cables and pipes using cable ties or wire
- Fast and stable fixing system to metal beams
- No drilling or welding required as the clamp is simply hammered onto the flange
- Wide range covers most flange thicknesses
- Two 3x10 mm clearance holes for easy insertion of cable ties to secure pipes
- Zinc flake coating for indoor, limited outdoor, humid and corrosive environments, resistant to corrosion in salt water mist for up to 480 hours (DIN 50021)

Suitable building materials

Very suitable



- Steel beams

Approvals and certificates



see assessment

CBR, zinc flake coating

Type	Art-No	$L_f \geq$ [mm]	t_f [mm]	d_f Length x Width [mm]	€ / pcs	[pcs]	[pcs]
CBR 1,5-4	9154CBR	18	1,5 - 4	3 x 10		100	600
CBR 4,0-10	9410CBR	25	4 - 10	3 x 10		100	600
CBR 10-15	91015CBR	25	10 - 15	3 x 10		100	900
CBR 15-20	91520CBR	25	15 - 20	3 x 10		100	600

Loads and installation parameters

Type	Recommended loads [kN]
CBR	0,15

Mounting

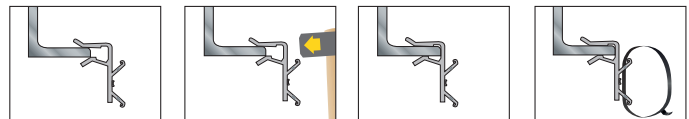
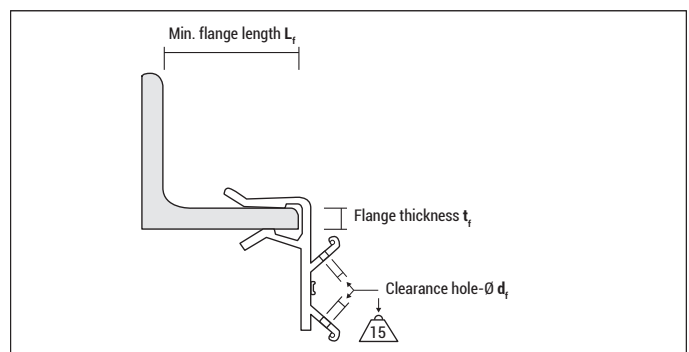

Hammer-on flange beam clip CC

Advantages



CC,
spring steel, zinc flake coated

- For pipes and cables
- Fast and stable fixing system to metal beams
- No drilling or welding required as the clamp is simply hammered onto the flange
- Quick clip-in of conduits or cables without the need for additional tools
- Wide range covers most flange thicknesses as well as pipe diameters
- Flexible positioning on flange or bar
- Zinc flake coating for indoor, limited outdoor, humid and corrosive environments, resistant to corrosion in salt water mist for up to 480 hours (DIN 50021)

Suitable building materials

Very suitable

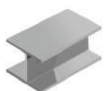

- Steel beams

Approvals and certificates



see assessment

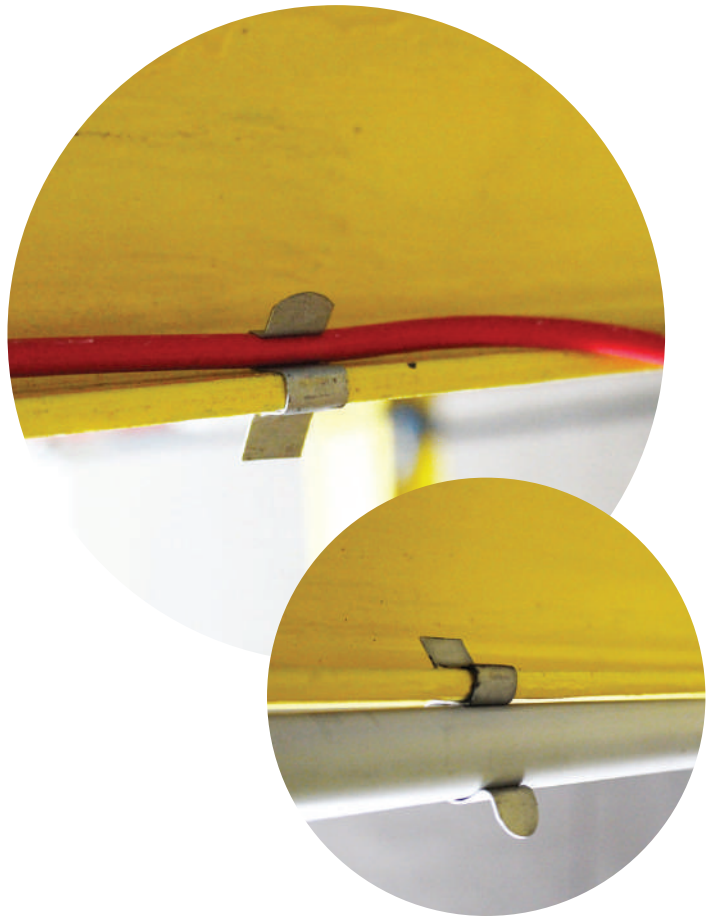

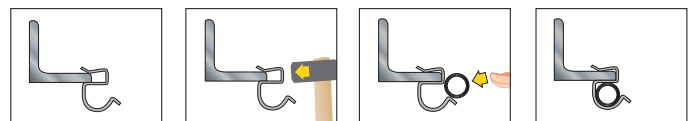
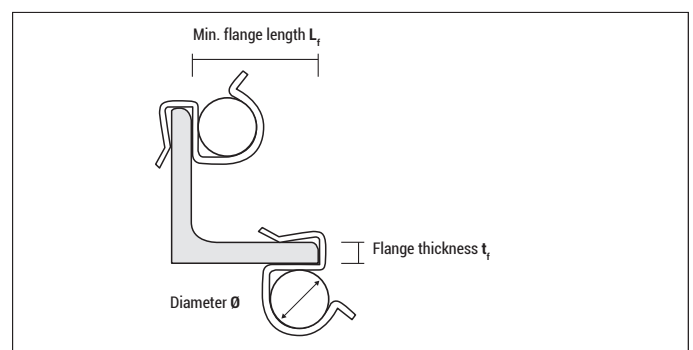

Mounting

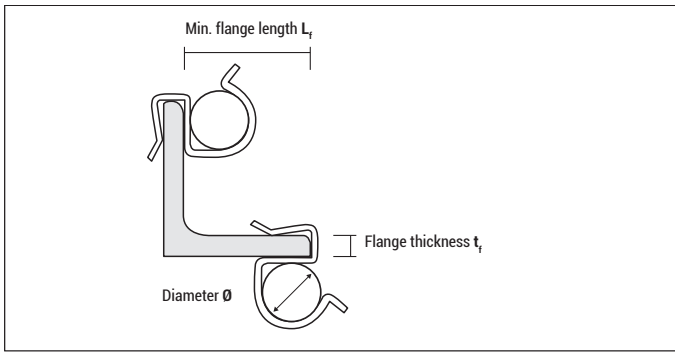

Hammer-on flange beam clip CC



CC, zinc flake coating

Type	Art-No	L _f [mm]	t _f [mm]	Ø [mm]	ε / pcs	 [pcs]	 [pcs]
CC 1,0-4,0, Ø6-7	947CC	18	1 - 4	6 - 7		100	1.800
CC 1,0-4,0, Ø8-9	949CC	18	1 - 4	8 - 9		100	1.800
CC 1,0-4,0, Ø10-11	9411CC	18	1 - 4	10 - 11		100	1.800
CC 1,0-4,0, Ø12-14	9414CC	18	1 - 4	12 - 14		100	1.800
CC 1,0-4,0, Ø15-18	9418CC	18	1 - 4	15 - 18		100	1.800
CC 1,0-4,0, Ø19-24	9424CC	18	1 - 4	19 - 24		100	900
CC 1,0-4,0, Ø25-30	9430CC	18	1 - 4	25 - 30		100	900
CC 4,0-7,5, Ø6-7	9757CC	25	4 - 7,5	6 - 7		100	1.800
CC 4,0-7,5, Ø8-9	9759CC	25	4 - 7,5	8 - 9		100	1.800
CC 4,0-7,5, Ø10-11	97511CC	25	4 - 7,5	10 - 11		100	1.800
CC 4,0-7,5, Ø12-14	97514CC	25	4 - 7,5	12 - 14		100	1.800
CC 4,0-7,5, Ø15-18	97518CC	25	4 - 7,5	15 - 18		100	900
CC 4,0-7,5, Ø19-24	97524CC	25	4 - 7,5	19 - 24		100	900
CC 4,0-7,5, Ø25-30	97530CC	25	4 - 7,5	25 - 30		100	900
CC 7,2-12,0, Ø6-7	9127CC	25	7,2 - 12	6 - 7		100	1.800
CC 7,2-12,0, Ø8-9	9129CC	25	7,2 - 12	8 - 9		100	1.800
CC 7,2-12,0, Ø10-11	91211CC	25	7,2 - 12	10 - 11		100	900
CC 7,2-12,0, Ø12-14	91214CC	25	7,2 - 12	12 - 14		100	900
CC 7,2-12,0, Ø15-18	91218CC	25	7,2 - 12	15 - 18		100	900
CC 7,2-12,0, Ø19-24	91224CC	25	7,2 - 12	19 - 24		100	900
CC 7,2-12,0, Ø25-30	91230CC	25	7,2 - 12	25 - 30		100	900

Hammer-on flange beam clip **CVA**

Advantages



CVA,
spring steel, zinc flake coated

- To suspend threaded rods from beam flanges
- Fast and stable fixing system to metal beams
- No drilling or welding required as the clamp is simply hammered onto the flange
- For the quick suspension of M6 or M8 threaded rods
- Ideal for fixing suspended ceilings and attaching pipe and conduit installations
- Zinc flake coating for indoor, limited outdoor, humid and corrosive environments, resistant to corrosion in salt water mist for up to 480 hours (DIN 50021)

Suitable building materials

Very suitable

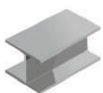

- Steel beams

Approvals and certificates



see assessment



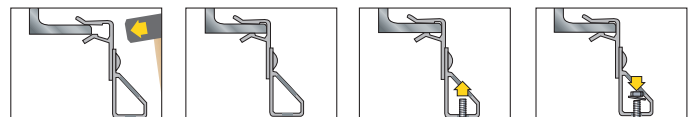
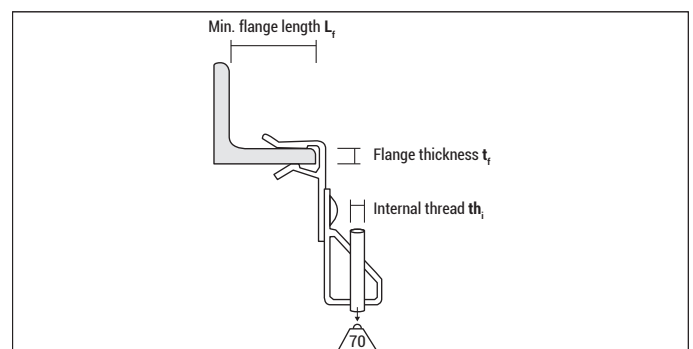

Mounting

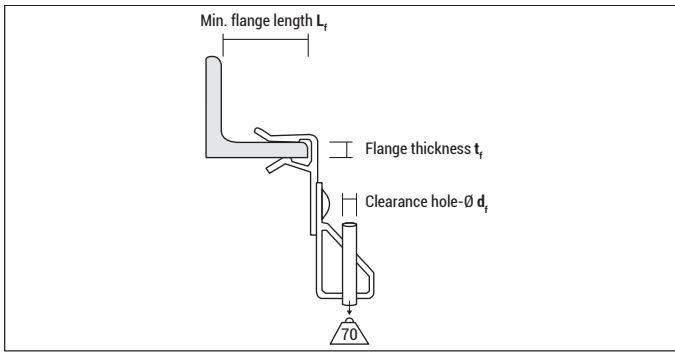

Hammer-on flange beam clip CVA



CVA, zinc flake coating

Type	Art-No	$L_f \geq$ [mm]	t_f [mm]	th_f [mm]	€ / pcs	 [pcs]	 [pcs]
CVA 1,5-4 M6	91546CVA	18	1,5 - 4	M6		50	450
CVA 1,5-4 M8	91548CVA	18	1,5 - 4	M8		50	450
CVA 4,0-10 M6	94106CVA	25	4 - 10	M6		50	450
CVA 4,0-10 M8	94108CVA	25	4 - 10	M8		50	450
CVA 10,0-15 M6	910156CVA	25	10 - 15	M6		50	300
CVA 10,0-15 M8	910158CVA	25	10 - 15	M8		50	300
CVA 15,0-20 M6	915206CVA	25	15 - 20	M6		50	300
CVA 15,0-20 M8	915208CVA	25	15 - 20	M8		50	300

Loads and installation parameters

Type	Recommended loads [kN]
CVA 1,5-4	0,7
CVA 4,0-10	0,7
CVA 10,0-15	0,7
CVA 15,0-20	0,7

Recommended load with safety factor ($\mu = 3$) under vertical tensile load

Hammer-on flange beam clip CAB M6

Advantages



CAB,
spring steel, zinc flake coated

- For clamp fixing, suspending threaded rods and hooks
- Fast and stable fixing system to metal beams
- No drilling or welding required as the clamp is simply hammered onto the flange
- Versatile in use: pre-mounted screw M6x9 for clamp fixing or M6 internal threads for suspending threaded rods
- Zinc flake coating for indoor, limited outdoor, humid and corrosive environments, resistant to corrosion in salt water mist for up to 480 hours (DIN 50021)

Suitable building materials

Very suitable

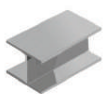

- Steel beams

Approvals and certificates



see assessment

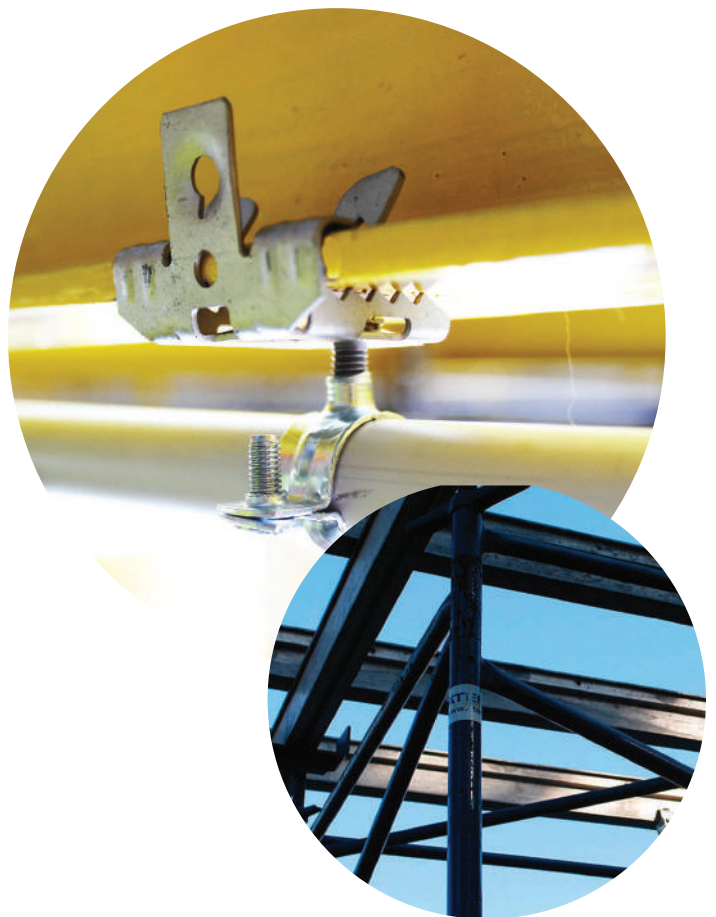

Mounting

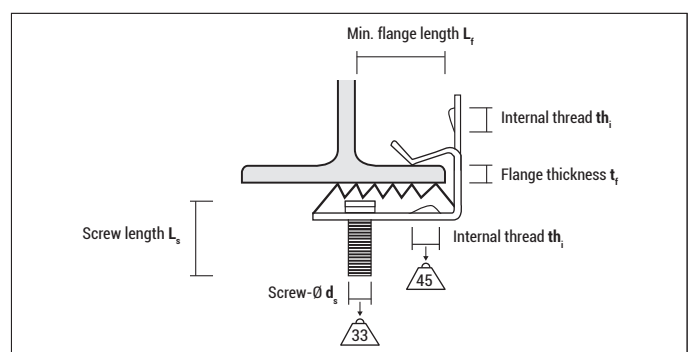

Fastening threaded rods

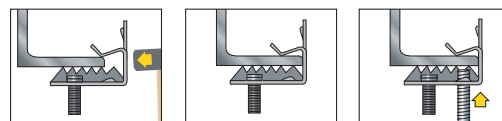

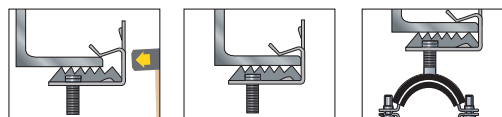

Suspending clamps

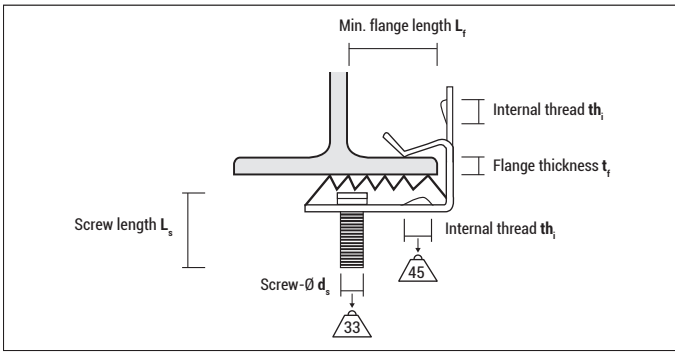

Hammer-on flange beam clip CAB M6



CAB, zinc flake coating

Type	Art-No	$L_f \geq$ [mm]	t_f [mm]	th_i [mm]	L_s [mm]	d_s [mm]	ϵ / pcs	 [pcs]	 [pcs]
CAB 3-7	9376CAB	35	3 - 7	M6	9	M6		50	450
CAB 7-13	97136CAB	35	7 - 13	M6	9	M6		50	300
CAB 14-20	914206CAB	35	14 - 20	M6	9	M6		50	300

Loads and installation parameters

Type	Recommended loads on M6 screw [kN]	Recommended loads on M6 internal thread
CAB 3-7	0,33	0,45
CAB 7-13	0,33	0,45
CAB 14-20	0,33	0,45

Recommended load with safety factor ($\mu = 3$) under vertical tensile load

Multi-functional beam clip **CMV**



Advantages



CMV, spring steel, zinc flake coated

- Ideally suited for easy and fast mounting of rods, M6-elements, clips or wires
- Fast and stable fixing system to metal beams
- Time-saving - quick assembly without drilling or welding simply by tightening the screw
- Multifunctional due to two M6-internal threads, two clearance holes 6,3 mm and one clearance hole 10,7 mm
- Zinc flake coating for indoor, limited outdoor, humid and corrosive environments, resistant to corrosion in salt water mist for up to 480 hours (DIN 50021)

Suitable building materials

Very suitable



- Steel beams

CMV, zinc flake coating

Approvals and certificates



see assessment

Mounting

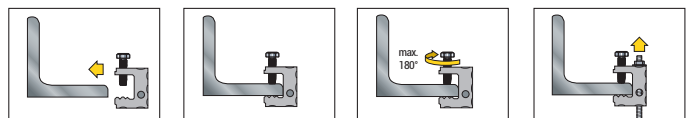
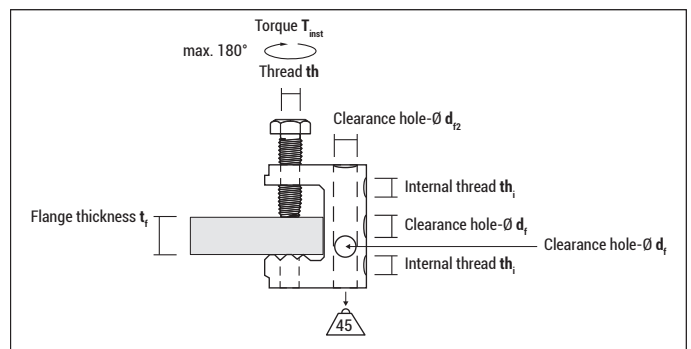

Type	Art-No	$t_f \leq$ [mm]	d_f [mm]	d_{r2} [mm]	th [mm]	th_1 [mm]	$T_{inst} <$ [Nm]	€ / pcs	[pcs]	[pcs]
CMV M6	96CMV	16	6,3	10,7	M6	M6	3		50	450

Loads and installation parameters

Type	Recommended loads [kN]
CMV M6	0,45

Recommended load with safety factor ($\mu = 3$) under vertical tensile load

Setscrew beam clamp PMV

Advantages



Body made of malleable cast iron, galvanised
pre-mounted with
- hexagon screw DIN 933, 8.8
- lock nut DIN 439

- Suspension of threaded rods from beam flanges
- Fast and stable fixing system to metal beams
- Quick assembly without drilling or welding simply by tightening the screw
- Heavy-duty mounting, load values verified by independent institutes
- For suspending threaded rods, heating, ventilation systems, pipe and sanitary installations, sprinkler systems steel construction and more
- Can be used directly, as the clamp, hexagon head screw and lock nut are pre-assembled
- Time saving, as hexagon head screw and lock nut can be tightened with the same key

Suitable building materials

Very suitable

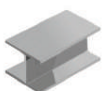

- Steel beams



Approvals and certificates



Mounting

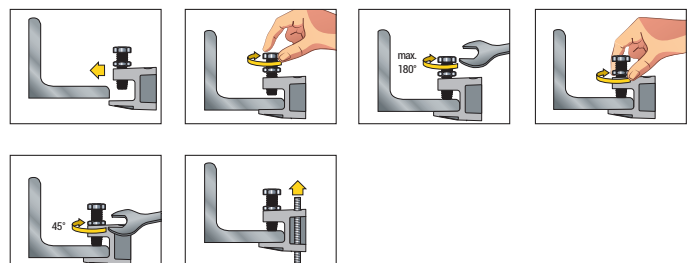
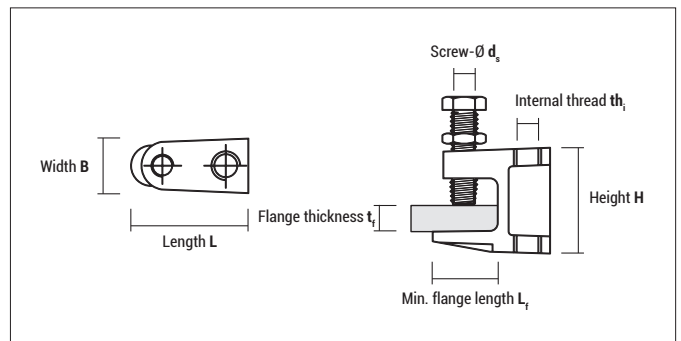

Setscrew beam clamp PMV

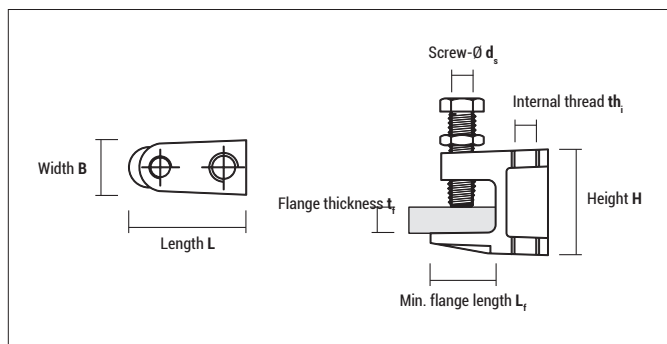

PMV, zinc plated

Type	Art-No	$L_f \geq$ [mm]	$t_f \leq$ [mm]	d_s [mm]	th_i [mm]	L [mm]	B [mm]	H [mm]	€ / pcs	[pcs]	[pcs]
PMV M8	98PMV	21	18	M8	M8	38	19	35		20	120
PMV M10	910PMV	29	23	M10	M10	50	21	42		20	120
PMV M12	912PMV	32	26	M10	M12	58	23,5	54		10	60

Loads and installation parameters

Type	Recommended loads [kN]
PMV M8	1,2
PMV M10	2,5
PMV M12	3,5

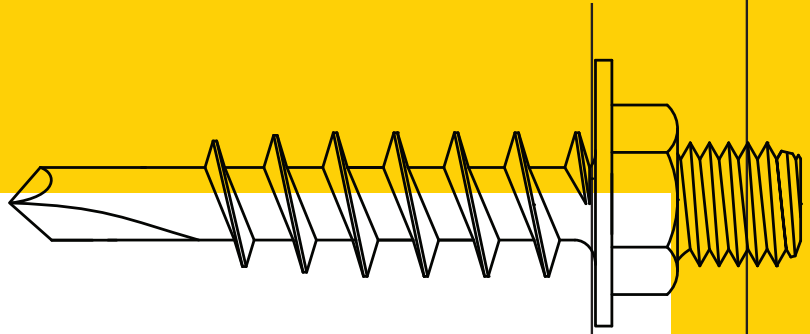

Special Fixings

Torab® ST
TPZ



311

313

Special self-drilling screw Torab® ST

Advantages



Torab® ST



Socket wrench LL for Torab® ST

- Self-drilling screws for metal sheets with a thickness 1-6 mm and a metric thread for the efficient installation of clamps, etc.
- Special setting tool with magnet for quick screwing of Torab® ST

Approvals and certificates



see assessment



Mounting

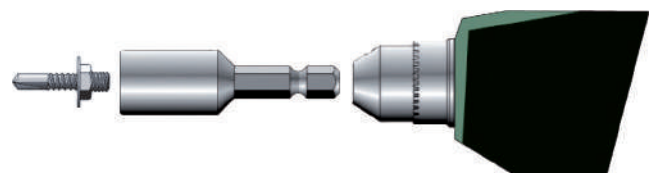
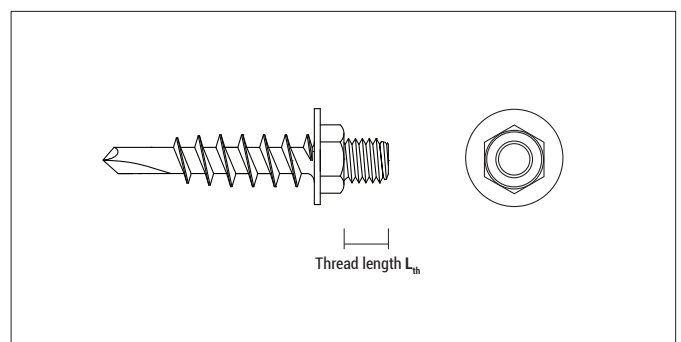

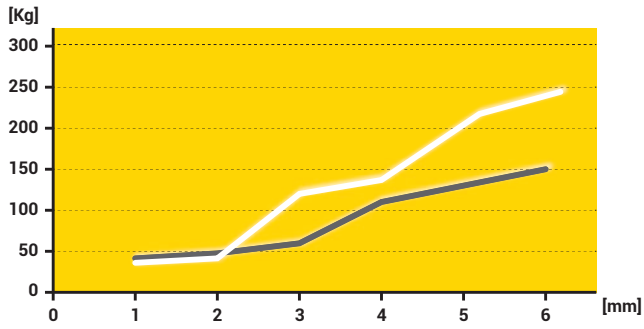

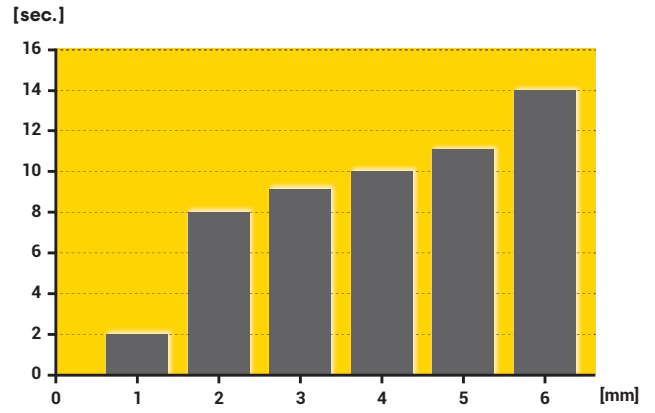

Recommended tension (white) and shear forces (grey) in kg depending on the metal sheet thickness; incl. safety factor



Drilling time in seconds for different metal sheet thicknesses





Torab® ST

Type	Art-No	Thread	Thread length L_{th} [mm]	Drive	Recommended sheet thicknesses [mm]	€ / 100 pcs	 [pcs]	 [pcs]
M6 x 6	96319M6TRB	M 6	6	SW 10	1 - 6		200	3.600
M8 x 10	96320M810TRB	M 8	10	SW 13	1 - 6		100	1.800
M8 x 15	96320M815TRB	M 8	15	SW 13	1 - 6		100	1.800



Socket wrench LL

Type	Art-No	Suitable for	€ / pc	 [pcs]	 [pcs]
LL TB-M6	910M6LLTRB	Torab® M6		1	-
LL TB-M8	913M8LLTRB	Torab® M8		1	-

Trapezoidal metal sheet hanger TPZ

Advantages



- Zinc plated
- Thickness: 2,5 mm
- Width: 25 mm
- Height adjustment possible
- Connection thread M8 or M10
- Use M8 screw/threaded rod to install TPZ



Suitable building materials

Very suitable



- Sandwich panel

Approvals and certificates



see assessment

Mounting



TPZ

Type	Art-No	Connecting thread	€/100 pcs	 [pcs]	 [pcs]
TPZ8F	98TPZF	M8		25	150
TPZ10F	910TPZF	M10		25	150

Blister, Assortment Box

Blister



316

Assortment box



324

Blister Assortment box



Advantages

- High quality fixings in small packs like blisters and assortment boxes
- Perfect for Do-it-Yourself (DIY) projects
- Wide range of fastening products for the daily fixing problems

"Made in Germany" Flag on the front for products developed and produced in Germany

Product name

Quality symbol for products made of UV-resistant nylon

Transparent blister hood for optimal product presentation



Practical EURO punching

Colour guiding system and smiles show the usability in different building materials - fast and simple.

On the back you will find important information concerning the mounting and technical data of the product.

Symbol in the catalogue:



All blisters are packed in a practical counter display





Multi-purpose plug MZ without collar

Type	Art-No	Drill hole Ø d_0 [mm]	Drill hole depth $h_1 \geq$ [mm]	Anchorage depth $h_{nom} \geq$ [mm]	Plug length L_d [mm]	Min. thickness of structural part h_{min}^1 [mm]	Screw-Ø d_s [mm]	€ / Blister	[pcs]	[Blister]
MZ 6	56MZ20	6	40	29	29	7,0	3 - 4,5		20	10
MZ 6x40	5640MZ10	6	50	40	40	7,0	3 - 4,5		10	10
MZ 8	58MZ15	8	60	48	48	9,5	4 - 6		15	10
MZ 10	510MZ10	10	75	59	59	12,0	6 - 8		10	10
MZ 12	512MZ5	12	85	71	71	15,0	8 - 10		5	10

¹ Min. thickness of structural part or board (e. g. for applications in plasterboard)

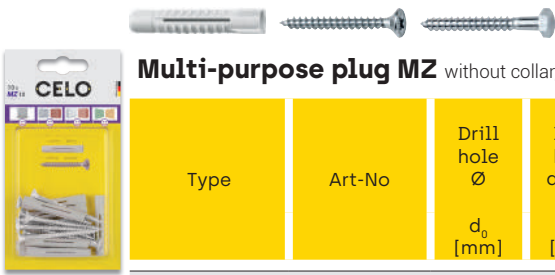

Multi-purpose plug MZ without collar, incl. screw

Type	Art-No	Drill hole Ø d_0 [mm]	Drill hole depth $h_1 \geq$ [mm]	Anchorage depth $h_{nom} \geq$ [mm]	Plug length L_d [mm]	Min. thickness of structural part h_{min}^1 [mm]	Screw-Ø x Length $d_s \times L_s$ [mm]	Type of screw	€ / Blister	[pcs]	[Blister]
MZ 6 SPS	56MZSZ20	6	40	29	29	7,0	4,5 x 40			20	10
MZ 6x40 SPS	5640MZSZ10	6	50	40	40	7,0	4,5 x 50			10	10
MZ 8 SPS	58MZSZ8	8	60	48	48	9,5	5,0 x 70			8	10
MZ 10 SKS	510MZK5	10	75	59	59	12,0	6,0 x 80			5	10
MZ 12 SKS	512MZK2	12	85	71	71	15,0	8,0 x 90			2	10

¹ Min. thickness of structural part or board (e. g. for applications in plasterboard)

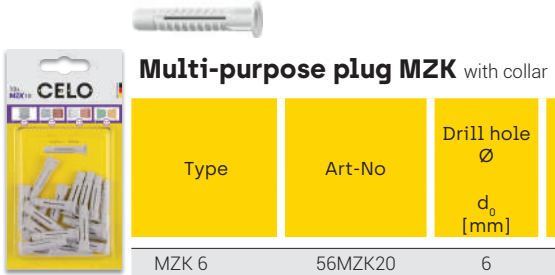

Multi-purpose plug MZK with collar

Type	Art-No	Drill hole Ø d_0 [mm]	Drill hole depth $h_1 \geq$ [mm]	Anchorage depth $h_{nom} \geq$ [mm]	Plug length L_d [mm]	Min. thickness of structural part h_{min}^1 [mm]	Screw-Ø d_s [mm]	€ / Blister	[pcs]	[Blister]
MZK 6	56MZK20	6	40	29	30	7,0	3 - 4,5		20	10
MZK 6x41	5641MZK10	6	50	40	41	7,0	3 - 4,5		10	10
MZK 8	58MZK15	8	60	48	49	9,5	4 - 6		15	10
MZK 10	510MZK10	10	75	59	60	12,0	6 - 8		10	10
MZK 12	512MZK5	12	85	71	72	15,0	8 - 10		5	10

¹ Min. thickness of structural part or board (e. g. for applications in plasterboard)

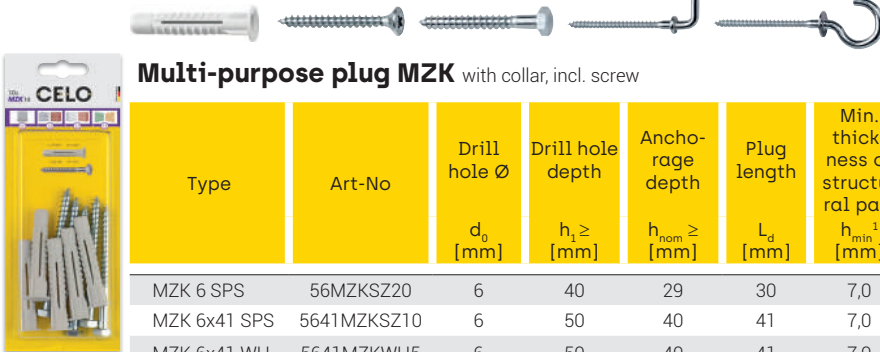

Multi-purpose plug MZK with collar, incl. screw

Type	Art-No	Drill hole Ø d_0 [mm]	Drill hole depth $h_1 \geq$ [mm]	Anchorage depth $h_{nom} \geq$ [mm]	Plug length L_d [mm]	Min. thickness of structural part h_{min}^1 [mm]	Screw-Ø x Length $d_s \times L_s$ [mm]	Type of screw	€ / Blister	[pcs]	[Blister]
MZK 6 SPS	56MZKSZ20	6	40	29	30	7,0	4,5 x 40			20	10
MZK 6x41 SPS	5641MZKSZ10	6	50	40	41	7,0	4,5 x 50			10	10
MZK 6x41 WH	5641MZKWH5	6	50	40	41	7,0	4,5 x 52			5	10
MZK 6x41 RH	5641MZKRH5	6	50	40	41	7,0	4,5 x 68			5	10
MZK 8 SPS	58MZKSZ8	8	60	48	49	9,5	5,0 x 70			8	10
MZK 8 WH	58MZKWH5	8	60	48	49	9,5	5,0 x 70			5	10
MZK 8 RH	58MZKRH5	8	60	48	49	9,5	5,0 x 86			5	10
MZK 10 SKS	510MZKK5	10	75	59	60	12,0	6,0 x 80			5	10
MZK 12 SKS	512MZKK2	12	85	71	72	15,0	8,0 x 90			2	10

¹ Min. thickness of structural part or board (e. g. for applications in plasterboard)



Plug FX without screw



Type	Art-No	Drill hole Ø d ₀ [mm]	Drill hole depth h ₁ ≥ [mm]	Anchorage depth h _{nom} ≥ [mm]	Plug length L _d [mm]	Screw-Ø d _s [mm]	€/ Blister	[pcs]	[Blister]
FX 5	55FX50	5	35	24	25	2,5 - 4		50	10
FX 6	56FX30	6	40	29	30	3,5 - 5		30	10
FX 8	58FX20	8	55	39	40	4,5 - 6		20	10
FX 10	510FX10	10	70	49	50	6 - 8		10	10
FX 12	512FX6	12	80	59	60	8 - 10		6	10



Plug FX incl. PZ chipboard screw (FX 5, 6 and 8) respectively hex-head wood screw (FX 10 and 12)



Type	Art-No	Drill hole Ø d ₀ [mm]	Drill hole depth h ₁ ≥ [mm]	Anchorage depth h _{nom} ≥ [mm]	Plug length L _d [mm]	Screw-Ø x Length d _s x L _s [mm]	Type of screw	€/ Blister	[pcs]	[Blister]
FX 5 SPS	55FXSZ20	5	35	24	25	3,5 x 35			20	10
FX 6 SPS	56FXSZ15	6	40	29	30	4,5 x 45			15	10
FX 8 SPS	58FXSZ10	8	55	39	40	5,0 x 60			10	10
FX 10 SKS	510FXK5	10	70	49	50	7,0 x 65			5	10
FX 12 SKS	512FXK2	12	80	59	60	8,0 x 80			2	10



Standard plug F without screw



Type	Art-No	Drill hole Ø d ₀ [mm]	Drill hole depth h ₁ ≥ [mm]	Anchorage depth h _{nom} ≥ [mm]	Plug length L _d [mm]	Screw-Ø d _s [mm]	€/ Blister	[pcs]	[Blister]
F 4	54NF20	4	30	20	20	2 - 3		20	10
F 4	54NF50	4	30	20	20	2 - 3		50	10
F 5	55NF20	5	35	25	25	2,5 - 4		20	10
F 5	55NF50	5	35	25	25	2,5 - 4		50	10
F 6	56NF20	6	40	30	30	3,5 - 5		20	10
F 6	56NF50	6	40	30	30	3,5 - 5		50	10
F 7	57NF20	7	40	30	30	4 - 5,5		20	10
F 7	57NF50	7	40	30	30	4 - 5,5		50	10
F 8	58NF20	8	55	40	40	4,5 - 6		20	10
F 8	58NF40	8	55	40	40	4,5 - 6		40	10
F 10	510NF5	10	70	50	50	6 - 8		5	10
F 10	510NF20	10	70	50	50	6 - 8		20	10
F 12	512NF5	12	80	60	60	8 - 10		5	10
F 12	512NF8	12	80	60	60	8 - 10		8	10

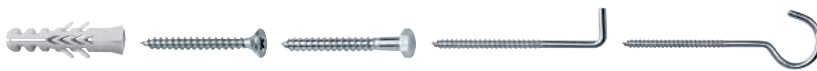

Standard plug F with screw



Type	Art-No	Drill hole Ø d ₀ [mm]	Drill hole depth h ₁ ≥ [mm]	Anchorage depth h _{nom} ≥ [mm]	Plug length L _d [mm]	Screw-Ø x Length d _s x L _s [mm]	Type of screw	€/ Blister	[pcs]	[Blister]
F 4 SPS	54NFSZ20	4	30	20	20	3,0 x 25			20	10
F 5 SPS	55NFSZ20	5	35	25	25	3,5 x 35			20	10
F 6 SPS	56NFSZ20	6	40	30	30	4,0 x 40			20	10
F 6 WH	56NFWH5	6	40	30	30	4,2 x 40			5	10
F 6 RH	56NFRH5	6	40	30	30	4,2 x 65			5	10
F 8 SKS	58NFK5	8	55	40	40	5,0 x 50			5	10
F 8 WH	58NFWH5	8	55	40	40	5,0 x 50			5	10
F 8 RH	58NFRH5	8	55	40	40	5,4 x 80			5	10
F 8 SPS	58NFSZ20	8	55	40	40	5,0 x 50			20	10
F 10 SKS	510NFK5	10	70	50	50	7,0 x 65			5	10
F 12 SKS	512NFK2	12	80	60	60	8,0 x 80			2	10
F 12 SKS	512NFK5	12	80	60	60	8,0 x 80			5	10
F 14 SKS	514NFK2	14	90	70	70	10,0 x 90			2	10



Standard plug FL long without screw



Type	Art-No	Drill hole Ø d ₀ [mm]	Drill hole depth h ₁ ≥ [mm]	Anchorage depth h _{nom} ≥ [mm]	Plug length L _d [mm]	Screw- Ø d _s [mm]	€/ Blister	[pcs]	[Blister]
FL 6x60	5660FL10	6	70	60	60	3,5 - 4,5		10	10
FL 8x80	5880FL10	8	90	80	80	4,5 - 5,5		10	10
FL 10x90	51090FL5	10	105	90	90	6 - 7		5	10



Aerated concrete plug GB without screw



Type	Art-No	Drill hole Ø d ₀ [mm]	Drill hole depth h ₁ ≥ [mm]	Anchorage depth h _{nom} ≥ [mm]	Plug length L _d [mm]	Wood screw Ø d _s [mm]	€/ Blister	[pcs]	[Blister]
GB 10	510GB4	10	65	55	55	4,5 - 6		4	10
GB 12	512GB4	12	70	60	60	7 - 8		4	10



Nail plug NP, zinc plated pre-assembled, NP 5 and 6: flat rim plug, NP8: countersunk plug



Type	Art-No	Drill hole Ø d ₀ [mm]	Drill hole depth h ₁ ≥ [mm]	Anchorage depth h _{nom} ≥ [mm]	Plug length L _d [mm]	Thick- ness of fixture t _{fix} ≤ [mm]	Drive	€/ Blister	[pcs]	[Blister]
NP 5x35	5535NP20	5	35	25	35	10	PZ 2		20	10
NP 5x50	5550NP20	5	35	25	50	25	PZ 2		20	10
NP 6x40	5640NP15	6	40	30	40	10	PZ 2		15	10
NP 6x60	5660NP15	6	40	30	60	30	PZ 2		15	10
NP 6x80	5680NP10	6	40	30	80	50	PZ 2		10	10
NP 8x60	5860NP10	8	50	40	60	20	PZ 3		10	10
NP 8x80	5880NP10	8	50	40	80	40	PZ 3		10	10
NP 8x100	58100NP10	8	50	40	100	60	PZ 3		10	10
NP 8x120	58120NP5	8	50	40	120	80	PZ 3		5	10
NP 8x135	58135NP5	8	50	40	135	95	PZ 3		5	10



Multifunction frame plug MFR SB TX, zinc plated

countersunk plug with countersunk screw



Type	Art-No	Drill hole Ø d ₀ [mm]	Drill hole depth h ₁ ≥ [mm]	Anchorage depth h _{nom} ≥ [mm]	Plug length L _d [mm]	Thick- ness of fixture t _{fix} ≤ [mm]	Recess	Type of screw	€/ Blister	[pcs]	[Blister]
8x60	5860MFRST4	8	60	50	60	10	TX 30			4	10
8x80	5880MFRST4	8	60	50	80	30	TX 30			4	10
10x60	51060MFRST4	10	60	50	60	10	TX 40			4	10
10x80	51080MFRST4	10	60/80	50/70	80	30/10	TX 40			4	10
10x100	510100MFRST4	10	60/80	50/70	100	50/30	TX 40			4	10
10x115	510115MFRST4	10	60/80	50/70	115	65/45	TX 40			4	10
10x135	510135MFRST4	10	60/80	50/70	135	85/65	TX 40			4	10
10x160	510160MFRST4	10	60/80	50/70	160	110/90	TX 40			4	10



Multifunction frame plug MFR SB SSKS, zinc plated

countersunk plug, hex-head screw with integral washer



Type	Art-No	Drill hole Ø d ₀ [mm]	Drill hole depth h ₁ ≥ [mm]	Anchorage depth h _{nom} ≥ [mm]	Plug length L _d [mm]	Thick- ness of fixture t _{fix} ≤ [mm]	Recess	Type of screw	€/ Blister	[pcs]	[Blister]
8x60	5860MFRSB4	8	60	50	60	10	SW10/TX 30			4	10
10x80	51080MFRSB4	10	60/80	50/70	80	30/10	SW13/TX 40			4	10
10x100	510100MFRSB4	10	60/80	50/70	100	50/30	SW13/TX 40			4	10
10x115	510115MFRSB4	10	60/80	50/70	115	65/45	SW13/TX 40			4	10
10x135	510135MFRSB4	10	60/80	50/70	135	85/65	SW13/TX 40			4	10
10x160	510160MFRSB4	10	60/80	50/70	160	110/90	SW13/TX 40			4	10





Multifunction frame plug MFR FB SSKS, zinc plated

flat rim plug, hex-head screw with integral washer



Type	Art-No	Drill hole Ø d ₀ [mm]	Drill hole depth h ₁ ≥ [mm]	Anchorage depth h _{nom} ≥ [mm]	Plug length L _d [mm]	Thickness of fixture t _{fix} ≤ [mm]	Recess	Type of screw	€/ Blister	[pcs]	[Blister]
8x80	5880MFRFB4	8	60	50	80	30	SW10/TX 30			4	10
10x60	51060MFRFB4	10	60	50	60	10	SW13/TX 40			4	10



Metal frame plug MR with countersunk screw (PZ 3)



Type	Art-No	Drill hole Ø d ₀ [mm]	Drill hole depth h ₁ ≥ [mm]	Anchorage depth h _{nom} ≥ [mm]	Sleeve length L _d [mm]	Thickness of fixture t _{fix} ≤ [mm]	€/ Blister	[pcs]	[Blister]
MR 10x92	51092MR6	10	50	30	92	62		6	10
MR 10x112	510112MR6	10	50	30	112	82		6	10
MR 10x132	510132MR6	10	50	30	132	102		6	10
MR 10x152	510152MR6	10	50	30	152	122		6	10

Incl. cover caps: 6 x white, 6 x brown



Window frame screw FBS zinc plated

with countersunk head (Ø 11 mm, TX 30), for wooden and plastic window frames



Type Ø - L	Art-No	Drill hole Ø d ₀ [mm]	Drill hole depth h ₁ ≥ [mm]	Anchorage depth h _{nom} ≥ [mm]	Drill hole Ø in window frame d _i [mm]	€/ Blister	[pcs]	[Blister]
FBS 7,5 x 112	575112FBS6	6	depends on building material,	depends on building material,	6,2		6	10
FBS 7,5 x 132	575132FBS6	6	h _{nom} + 10 mm	see table page 64	6,2		6	10
FBS 7,5 x 152	575152FBS6	6			6,2		6	10

Incl. cover caps: 6 x white, 6 x brown



ResiFIX PYSF (styrene free)



Type	Art-No	Content [ml]	Mixings nozzles included [pcs]	Shelf life [months]	ETA	€/ pc	[pcs]	[Blister]
PY 165 SF	165PSF	165	2	18			1	12



with centering cap



Plastic sleeves SH



Type	Art-No	Drill hole Ø d ₀ [mm]	Drill hole depth h ₀ [mm]	Suitable for Thread Ø	€/ Blister	[pcs]	[Blister]
SH 12x80	51280SH4	12	85	M6, M8		4	10
SH 16x85	51685SH4	16	90	M8, M10		4	10
SH 16x130	515130SH4	16	135	M8, M10		4	10
SH 20x85	52085SH4	20	90	M12, M16		4	10

Note: The system (resin, sleeve and anchor rod) is only approved completely if approved components are used.



Internal threaded sleeves IGH

Type	Art-No	Drill hole Ø d ₀ [mm]	Drill hole depth h ₀ [mm]	Suitable for Thread Ø	Outer Ø [mm]	€ / Blister	[pcs]	[Blister]
IGH M8x80	5880IGHM4	14	90	M8	12		4	10
IGH M10x80	51080IGHM4	16	90	M10	14		4	10



Anchor studs RESI AST, zinc plated



Type	Art-No	Thread	Length L [mm]	€ / Blister	[pcs]	[Blister]
8x110	58110VMAST4	M8	110		4	10
10x130	510130VMAST4	M10	130		4	10
12x160	512160VMAST4	M12	160		4	10

Note: The system (resin, sleeve and anchor rod) is only approved completely if approved components are used.



Standing toilet installation set WCS



Type	Art-No	Plug-Ø d ₀ [mm]	Plug length L _d [mm]	Anchorage depth h _{nom} [mm]	Screw Ø d _s [mm]	Screw length L _s [mm]	Type of screw	€ / Blister	[pcs]	[Blister]
WCS	5WCS2	8	50	50	6	85			2	10



Vanity installation set WT



Type	Art-No	Plug-Ø d ₀ [mm]	Plug length L _d [mm]	Anchorage depth h _{nom} [mm]	Screw Ø d _s [mm]	Screw length L _s [mm]	Type of screw	€ / Blister	[pcs]	[Blister]
WT	5WT2	14	79	79	10	140			2	10

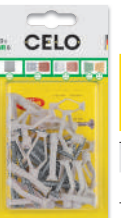

Cavity fixing HR



Type	Art-No	Drill hole Ø d ₀ [mm]	Board thickness h _{p min-max} [mm]	Screw- Ø x Length d _s x L _s [mm]	Plug length L _d [mm]	€ / Blister	[pcs]	[Blister]
HR 6x30 SPS	56HRSZ20	6	3 - 14	3,5 x 50	30		20	10
HR 8x40 SPS	58HRSZ20	8	10 - 16	4,0 x 60	40		20	10



Cavity plug metal HRM



Type	Art-No	Drill hole Ø d ₀ [mm]	Board thickness h _{p min-max} [mm]	Thread	Screw length L _s [mm]	Plug length L _d [mm]	Type of screw	€ / Blister	[pcs]	[Blister]
4x20	5420HRM5	8	3 - 18	M4	52	46			5	10
4x24	5424HRM5	8	18 - 24	M4	58	52			5	10
5x16	5516HRM5	11	3 - 16	M5	58	52			5	10
5x16 RH	5516HRMRH4	11	3 - 16	M5	58	52			4	10
5x16 WH	5516HRMWH4	11	3 - 16	M5	58	52			4	10
5x32	5532HRM5	11	14 - 32	M5	71	65			5	10
5x32 RH	5532HRMRH4	11	14 - 32	M5	71	65			4	10
5x32 WH	5532HRMWH4	11	14 - 32	M5	71	65			4	10
6x16	5616HRM5	13	3 - 16	M6	58	52			5	10
6x32	5632HRM5	13	14 - 32	M6	71	65			5	10

Installation plier MZA 100 for HRM



Type	Art-No	€ / pcs	[pcs]	[pcs]
MZA 100	9MZA00		1	-



Plasterboard plug GKD without screw



Type	Art-No	Plug length L _d [mm]	Max. board thickness h _{p max} [mm]	Screw- Ø d _{s min-max} [mm]	Screw length L _s [mm]	€ / Blister	[pcs]	[Blister]
GKD	5GKD10	35	9- 12,5	3,0 - 4,5	22 + t _{fix}		10	10



Plasterboard plug GKD with screw



Type	Art-No	Plug length L _d [mm]	Max. board thickness h _{p max} [mm]	Screw- Ø x Length d _s x L _s [mm]	Type of screw	€ / Blister	[pcs]	[Blister]
GKD PZ	5GKDPZ6	35	9- 12,5	4,0 x 40			6	10



Plasterboard plug GKDZ without screw



Type	Art-No	Plug length L _d [mm]	Max. board thickness h _{p max} [mm]	Screw- Ø d _s [mm]	Screw length L _s [mm]	€ / Blister	[pcs]	[Blister]
GKDZ 37	537GKDZ10	37	9	4,5	19 + t _{fix}		10	10



Plasterboard GKDZ with screw



Type	Art-No	Plug length L _d [mm]	Max. board thickness h _{p max} [mm]	Screw- Ø x Length d _s x L _s [mm]	Type of screw	€ / Blister	[pcs]	[Blister]
GKDZ 37 PZ	537GKDZSZ6	37	9	4,5 x 35			6	10

CELO



Cavity plug universal BT plus with screw



Type	Art-No	Drill hole Ø d ₀ [mm]	Board thickness h _p min-max [mm]	Thread	Screw length L _s [mm]	Recess	€/ Blister	[pcs]	[Blister]
BT M4 LO	54BTLO4	13	10 - 70	M4	50	PZ2 / slot		4	10
BT M5 LO	55BTLO4	13	10 - 70	M5	62	PZ2 / slot		4	10
BT M6 LO	56BTLO4	13	10 - 70	M6	62	PZ2 / slot		4	10
BT M8 K	58BTK2	18	10 - 70	M8	60	SW13 / hex		2	10



Spring toggle FK-S with washer and hexagon nut

Spring toggle FK-HS with round hook, washer and hexagon nut



Type	Art-No	Drill hole Ø d ₀ [mm]	Max. board thickness h _p max [mm]	Thread	Plug length L _s [mm]	Min. space behind board t _h [mm]	€/ Blister	[pcs]	[Blister]
FK-S 3x85 *	9390FKS	11	65	M3	85	28		2	10
FK-S 4x90	5495FKS2	14	65	M4	90	35		2	10
FK-HS 3x100 *	9385FKHS	11	40	M3	100	28		2	10
FK-HS 4x95	54100FKHS2	14	30	M4	95	35		2	10

*discontinued article, delivery while stocks last



Insulation plug IPL



Type	Art-No	Plug length L _a [mm]	Recess	Screw Ø d _s [mm]	Screw length L _s [mm]	€/ Blister	[pcs]	[Blister]
IPL 60	560IPL4	58	TX 40	4,5 - 5,0	30 + t _{fix}		4	10
IPL 95	595IPL2	95	SW 13	8 / 10 / M8	40 + t _{fix}		2	10

IPL 60: Head-Ø 25 mm

IPL 95: Head-Ø 32 mm, incl. 1x screw M8 x 30 as setting tool



Insulation plug IPL incl. screw PZ2



Type	Art-No	Plug length L _a [mm]	Recess [mm]	Screw- Ø x Length d _s x L _s [mm]	Type of screw	€/ Blister	[pcs]	[Blister]
IPL 60	560IPLPZ4	58	TX 40	4,5 x 40	➔⊕		4	10



Insulation screw IPS 80 incl. screws made of stainless steel A2, PH2



Type	Art-No	Plug length L _a [mm]	Plug Recess	Clearance hole d _i [mm]	Screw- Ø x Length d _s x L _s [mm]	Type of screw	€/ Blister	[pcs]	[Blister]
IPS 80 PH	5180IPSPH4	80	TX 25	8 - 10	3,5 x 13 + 3,5 x 16	➔⊕		4	10



Brass plug ME



Type	Art-No	Drill hole Ø d ₀ [mm]	Drill hole depth h ₁ ≥ [mm]	Anchor length L _a [mm]	Thread	€/ Blister	[pcs]	[Blister]
ME 6	5L6ME5	8	27	23	M6		5	10
ME 8	5L8ME4	10	35	30	M8		4	10



Bolt anchor BA plus for non-cracked concrete



Type	Art-No	Drill hole Ø d ₀ [mm]	Drill hole depth h ₁ ≥ [mm]	Anchorage depth h _{ef} ≥ [mm]	Anchor length L _a [mm]	Thickness of fixture t _{fix} ≤ [mm]	Thread	€ / Blister	[pcs]	[Blister]
8x85/20	5885BA2	8	60	45	85	20	M8		2	10
10x92/17	51090BA2	10	65	50	92	17	M10		2	10
10x125/50	510120BA2	10	65	50	125	50	M10		2	10



Bolt anchor BAZ for cracked and non-cracked concrete



Type	Art-No	Drill hole Ø d ₀ [mm]	Drill hole depth h ₁ ≥ [mm]	Anchorage depth h _{ef} ≥ [mm]	Anchor length L _a [mm]	Thickness of fixture t _{fix} ≤ [mm]	Thread	€ / Blister	[pcs]	[Blister]
8x72/10	5874BAZ2	8	60	45	72	10	M8		2	10
10x92/10	51095BAZ2	10	75	60	92	10	M10		2	10
12x118/20	512115BAZ2	12	90	70	118	20	M12		2	10

discontinued article, delivery while stocks last



Expansion anchor ZT / ZE / M / MO, zinc plated



Type	Art-No	Outer Ø [mm]	Anchor length L _a [mm]	Thickness of fixture t _{fix,max} [mm]	Thread	Type	€ / Blister	[pcs]	[Blister]
ZT 6x50	5B650ZT4	12	50	5	M6			4	10
ZT 8x60	5B860ZT4	14	60	10	M8			4	10
ZT 10x80	5B1080ZT2	16	80	20	M10			2	10
ZT 10x100	5B10100ZT2	16	100	40	M10			2	10
ZE 6x65	5B665ZE4	12	65	10	M6			4	10
ZE 6x85	5B685ZE4	12	85	25	M6			4	10
ZE 8x70	5B870ZE4	14	70	10	M8			4	10
ZE 8x120	5B8120ZE2	14	120	60	M8			2	10
ZE 10x85	5B1085ZE2	16	85	15	M10			2	10
ZE 10x130	5B10130ZE2	16	130	60	M10			2	10
ZE 12x100	5B12100ZE2	20	100	15	M12			2	10
ZE 12x115	5B12115ZE2	20	115	30	M12			2	10
M 6x50	5B650ZM2	12	50	-	M6			2	10
M 8x65	5B865ZM2	14	65	-	M8			2	10
MO 6x50	5B650ZMO2	12	50	-	M6			2	10
MO 8x65	5B865ZMO2	14	65	-	M8			2	10



RI clamp set



Type	Art-No	Plug-Ø [mm]	Plug length [mm]	Recommended Load ≤ [kg]	Content	€ / Blister	[pcs]	[Blister]
FX 10 RI 22	22RIEDRN	10	50	80	FX 10 + M8 x 80 + RI 22		2	15
FX 10 RI 28	28RIEDRN	10	50	80	FX 10 + M8 x 80 + RI 28		2	15
FX 10 RI 35	35RIEDRN	10	50	80	FX 10 + M8 x 80 + RI 35		2	15
FX 10 RI 40	40RIEDRN	10	50	100	FX 10 + M8 x 80 + RI 40		2	15
FX 10 RI 50	50RIEDRN	10	50	100	FX 10 + M8 x 80 + RI 50		2	15
FX 10 RI 60	60RIEDRN	10	50	100	FX 10 + M8 x 80 + RI 60		2	15
FX 10 RI 75	75RIEDRN	10	50	150	FX 10 + M8 x 80 + RI 75		2	15
FX 12 RI 90	90RIEDRN	12	60	150	FX 12 + M10 x 100 + RI 90		2	15
FX 12 RI 110	110RIEDRN	12	60	150	FX 12 + M10 x 100 + RI 110		2	15

Suitable pipe diameters see page 279

Assortment boxes



Assortment box F with screw (210 pieces in total)



Type	Art-No	Box contains	Drill hole Ø d ₀ [mm]	Drill hole depth h ₁ ≥ [mm]	Plug length L _d [mm]	Screw Ø x Length d _s x L _s [mm]	€ / box	[box]	Min. sales unit [pcs]
F	MIXNFSZ210	60 Standard plug F 5 incl. SPS 3,5x35 V, Pozi 30 Standard plug F 6 incl. SPS 4,5x45 V, Pozi 15 Standard plug F 8 incl. SPS 5,0x60 V, Pozi	5 6 8	35 40 55	25 30 40	3,5 x 35 4,5 x 45 5,0 x 60		1	5

Packed in robust plastic box



Assortment box MZK and F without screw (156 pieces in total)



Type	Art-No	Box contains	Drill hole Ø d ₀ [mm]	Drill hole depth h ₁ ≥ [mm]	Plug length L _d [mm]	Screw Ø d _s [mm]	€ / box	[box]	Min. sales unit [pcs]
MZK and F	MIXNFMZK156	30 Multi-purpose plug MZK 6 15 Multi-purpose plug MZK 8 6 Multi-purpose plug MZK 10 60 Standard plug F 5 30 Standard plug F 6 15 Standard plug F 8	6 8 10 5 6 8	40 60 75 35 40 55	30 49 60 25 30 40	3,0 - 4,5 4,0 - 6,0 6,0 - 8,0 2,5 - 4,0 3,5 - 5,0 4,5 - 6,0		1	5

Packed in robust plastic box



Assortment box MZK with screw (102 pieces in total)



Type	Art-No	Box contains	Drill hole Ø d ₀ [mm]	Drill hole depth h ₁ ≥ [mm]	Plug length L _d [mm]	Screw Ø x Length d _s x L _s [mm]	€ / box	[box]	Min. sales unit [pcs]
MZK	MIXMZKSZ102	30 Multi-purpose plug MZK 6 incl. SPS 4,5x45 V, Pozi 15 Multi-purpose plug MZK 8 incl. SPS 5,0x60 V, Pozi 6 Multi-purpose plug MZK 10 incl. SKS 6,0x80 DIN 571	6 8 10	40 60 75	30 49 60	4,5 x 45 5,0 x 60 6,0 x 80		1	5

Packed in robust plastic box

Small Things Matter

CELO Befestigungssysteme GmbH
Industriestraße 6
86551 Aichach, Deutschland
www.celofixings.de
Hotline: +49 [0] 8251-90485-0
Telefax: +49 [0] 8251-90485-49
E-mail: info@celofixings.de